

GUEST EDITOR KEVIN KELLY'S MINI-CATALOG  
MAYA LIN: THINKING WITH HER HANDS

# Whole Earth

Access to Tools, Ideas, and Practices Winter 2000

**TOOLS ARE  
REVOLUTION**

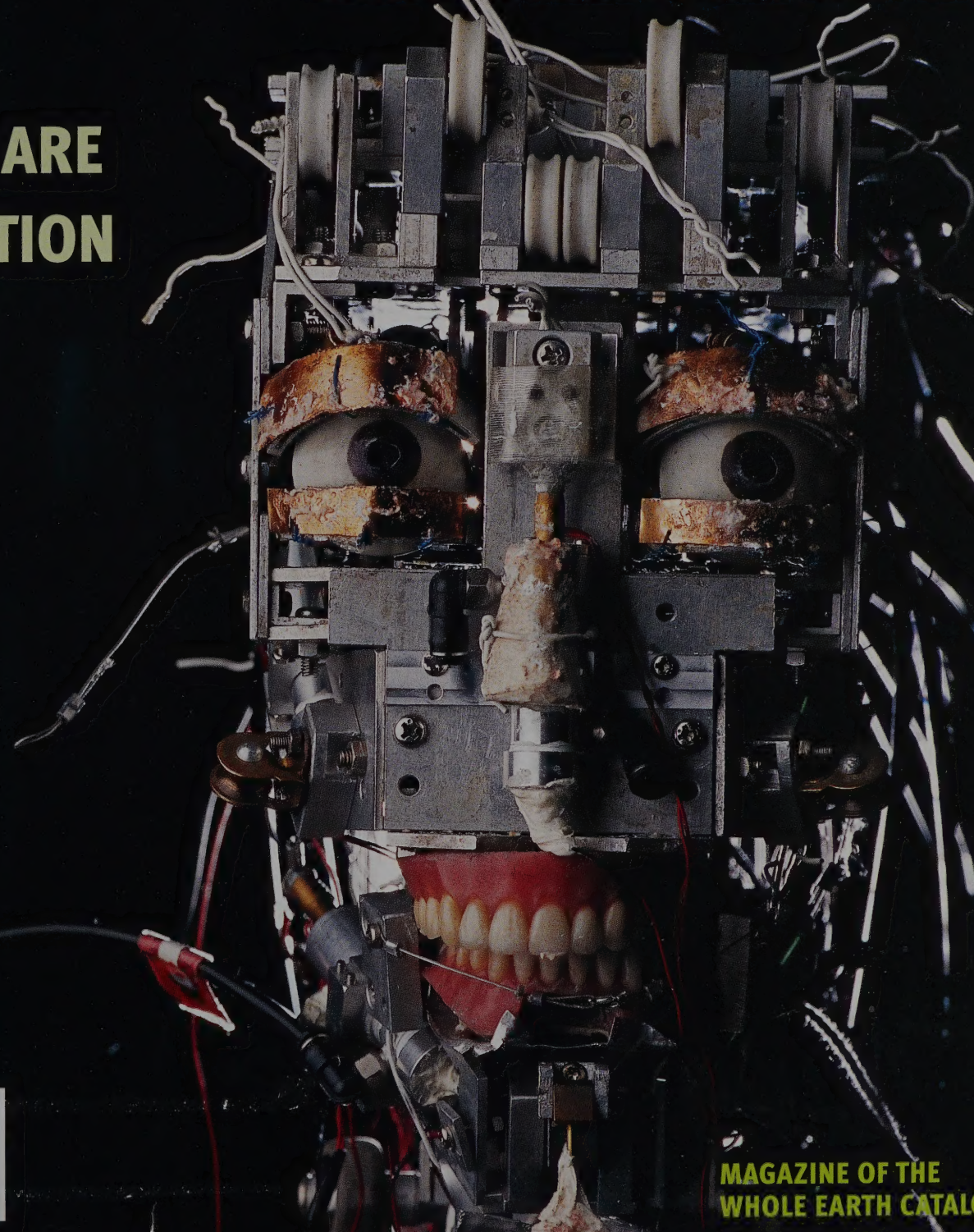

\$6.95/\$8.50 CDN



**MAGAZINE OF THE  
WHOLE EARTH CATALOG**



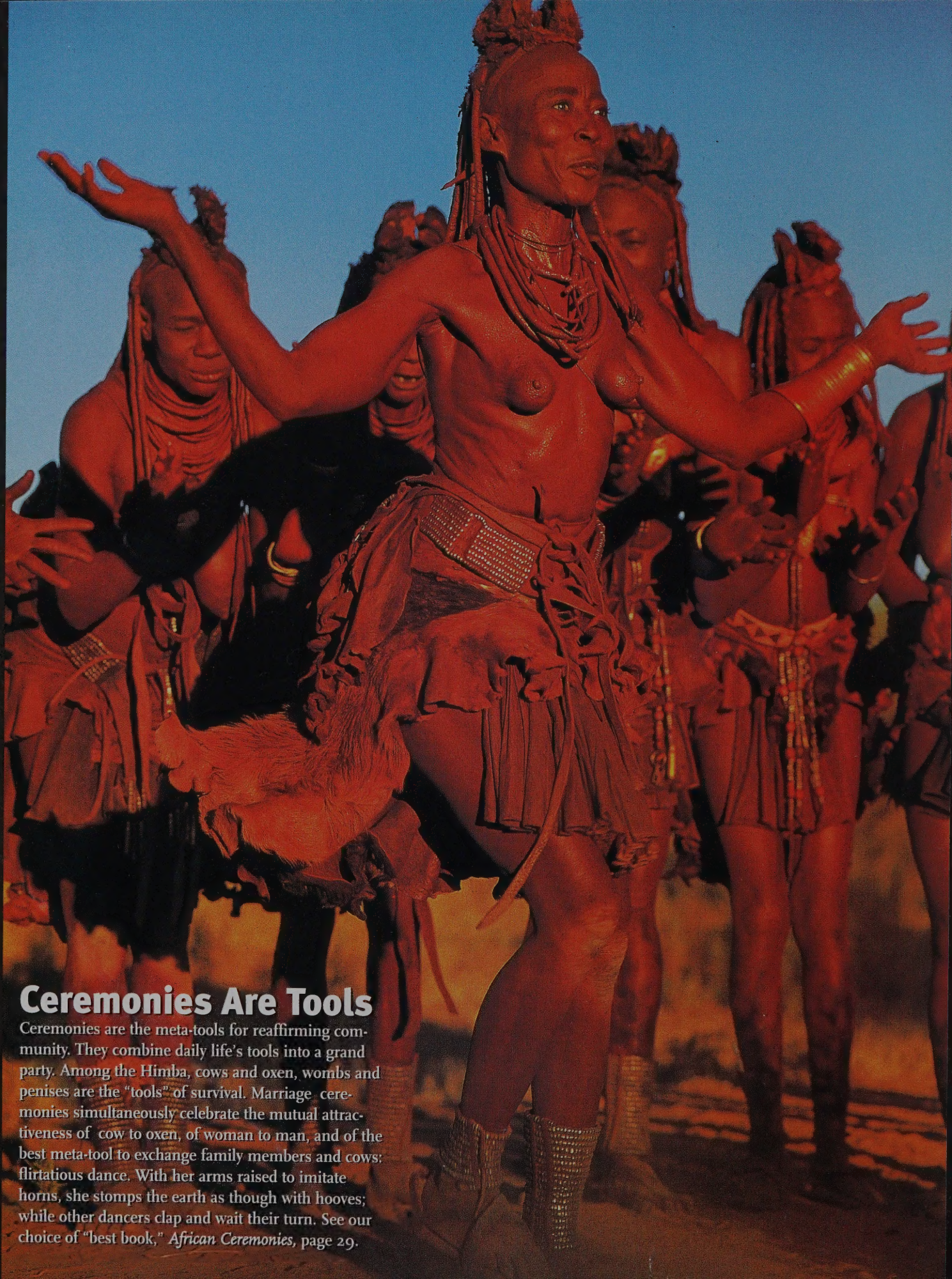

## Ceremonies Are Tools

Ceremonies are the meta-tools for reaffirming community. They combine daily life's tools into a grand party. Among the Himba, cows and oxen, wombs and penises are the "tools" of survival. Marriage ceremonies simultaneously celebrate the mutual attractiveness of cow to oxen, of woman to man, and of the best meta-tool to exchange family members and cows: flirtatious dance. With her arms raised to imitate horns, she stomps the earth as though with hooves; while other dancers clap and wait their turn. See our choice of "best book," *African Ceremonies*, page 29.



# Discover the grassroots movements that are revitalizing education

**P**arents and educators are exploring new ways to nourish young people's creativity, compassion, and critical intelligence. With our schools being mechanized by rigid standards and high stakes testing, these democratic, community-based models offer vital alternatives.

## *Paths of Learning*

**O**nly one magazine gives you an intimate, in-depth perspective on diverse non-traditional approaches to teaching and learning. *Paths of Learning* describes what goes on in holistic and progressive schools, why parents choose to "unschool," why there is a growing popular movement opposed to standardized testing, and much more. *Paths of Learning* also features insightful interviews with educational innovators, book reviews, and a resource directory. Send for a free sample issue.

Quarterly - \$19.95/yr.

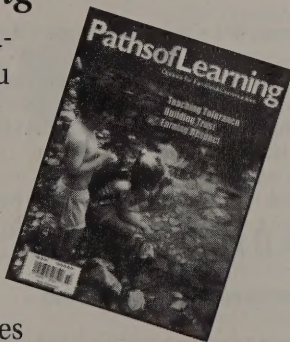

## *Creating Learning Communities*

**T**hirty authors and activists in progressive education, cooperative homeschooling, and sustainable community development describe successful models of lifelong learning resource centers. This unique volume is packed with stirring observations on the possibilities of education, practical suggestions and guides to resources.

Riane Eisler, author of *Tomorrow's Children*, *The Chalice and the Blade* and other inspiring works, calls this "a wonderful, extremely useful book illustrating how creative partnership-oriented learning communities are springing up all over the world."

Published July, 2000 - 378 pages - \$21.95

## **Foundation for Educational Renewal**

P.O. Box 328, Brandon, VT 05733  
(800) 639-4122

visit [www.PathsOfLearning.net](http://www.PathsOfLearning.net), a free online database and guide to our publications, including the new book series Foundations of Holistic Education.

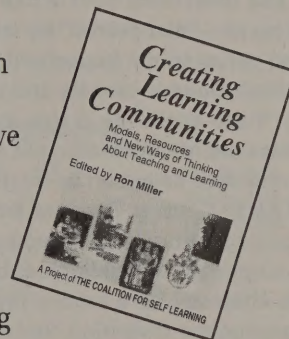



## GUEST EDITOR:

Kevin Kelly, pages 4 to 71.

Kevin has not reviewed for *Whole Earth* for a decade. While he worked as editor of *Wired*, he kept a mental carton of tools and books he would have put in *Whole Earth*. (It's hard to shake the inclusiveness of our magazine.) The contents of this mental carton became mixed with another desire: to prepare an actual box for each of his two daughters to receive when they are about twenty—the finest books and tools for everything.

This issue has been filled from books and tools around his home—"discovered" by taking a moment and perusing the household shelves; maybe poking around in closets and drawers, and saying "these excite me at this moment of life." The items are idiosyncratic; not an attempt at a comprehensive selection as might appear in a *Whole Earth Catalog*. They are *Whole Earth* old-style: contemporary, spontaneous, and keen. I am surprised (and delighted) by how many of his choices I have around my house and have overlooked reviewing, including incredible finds like *African Ceremonies* (page 29). "Idiosyncratic" means: not necessarily the best buy nor even the best tool that might have been discovered from extensive *Consumer Reports*-type testing; and the choices are not necessarily the best by "sustainable" criteria such as employee issues, women's advancement, or environmental commitment to less harmful production and materials. Kevin unabashedly upholds an old *Whole Earth* attitude: personal experience as prime value.

Kevin just returned from China where he traveled with his two daughters (nine and eleven), who acted as his translators. His prodigious thinking triggered the All Species Inventory (*Whole Earth*, Fall 2000) and helped jump-start The Long Now Project (page 6). His latest book, *New Rules for the New Economy*, extols a "friction-free economy." You can read his earlier *Out of Control* online ([well.com/user/kk/OutOfControl](http://well.com/user/kk/OutOfControl)). I thank him for his enthusiasm, legacy, and volunteered time in creating this section.

— Peter Warshall, Editor

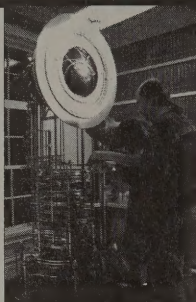

Tools Are the Revolution • Kevin Kelly 4

How to Design a 10,000-Year Clock • Danny Hillis 6

The Rosetta Disk • Kevin Kelly 10

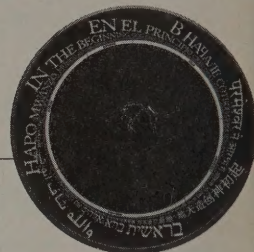

## PLACES

12 ExactSet Travel Clock • Analog Atomic Wall Clock • IWC Fliegerchronograph Watch • Correlated History of Earth

13 Histomap of World History • Chronicle of the World

14 Atlas of the Year 1000 • The Year 1000

15 World War II The Lost Color Archives • The Victorian Internet • Rush to Riches

16 Sky Atlas 2000.0 • Magnificent Universe

17 The Universe Map • Earth From Above

18 The Times Atlas of the World • Ethnologue

19 Baraka • Mercator's World • Breath by Breath

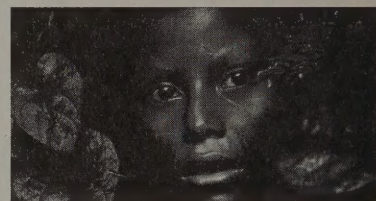

## WHOLE SYSTEMS

20 Skulls and Bones • Make Your Own Dinosaur Out of Chicken Bones

21 The Field Guide to Bigfoot, Yeti, and Other Mystery Primates Worldwide • Trailmaster Trail Monitor

22 Garmin GPS • Thommen Altimeter • Brunton Classic Compass • Kestrel 3000 Pocket Weather Meter

23 Danner Boots • Skillers Duckweave Pants • Mephisto Shoes • Nike Air Mocs

24 Ridge Rest Sleeping Pad • Tilley Hat • CamelBak Hydration Systems • Otterbox • Princeton Tec Matrix LED Headlamp

25 SEAL Pup Knife • Swiss Army Champ Knife • Boye Knives • Sharpmaker



## NOMADICS

26 Rick Steves' Europe Through the Back Door

27 Leica Trinovid Binoculars • Travelpro Rollaboards • World Heritage Sites • The Secret Museum of Mankind

28 Sadhus

29 African Ceremonies • Passages

30 Fantasy Worlds • Rough Guide World Music

31 The Alan Lomax Collection • Jean Shepherd • Listen to This!

32 Books on Tape (Again)

33 Bose Acoustic Noise Cancelling Headset • BlackBerry • Good Cheap Almost New Cars • Honda EU Series Generators • TalkAbouts

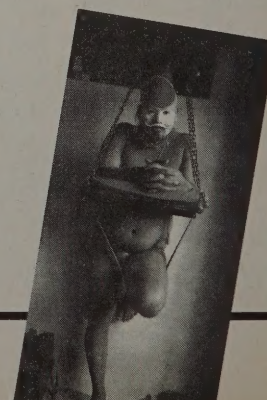



## SHELTER AND LIVELIHOOD

34 Home Comforts • Smarthome.com

35 The Gardener's Guide to Growing Temperate Bamboos • Building Bamboo Fences

36 Self Reliance Journal • Handmade Houseboats

37 Making the Best of Basics • Penzeys Spices

38 Ultimate Fit or Fat • Body for Life

39 Power Bars • The Merck Manual of Medical Information

40 Die Broke • Fidelity Charitable Gift Fund • The New Yorker Book of Money Cartoons

41 A Framework for Understanding Poverty • Foreign Affairs



## TOOLS AND TECHNOLOGY

42 McMaster-Carr Online Catalog • eBay • Pocket Ref

43 Don Lancaster • Sewing Awl • Hiring Smart!

44 Rembrandts in the Attic • Case Against Patents • High Tech Start Up

45 The Innovator's Dilemma

46 Cruising Home Depot with Jay Baldwin

48 T-Handle Taper Reamer • Rechargeable NiMH Batteries • Dimensionator Tapeless Tape Measurer • Panasonic Cordless Drill

49 Telecosm • Crypto • My Tiny Life

50 Levenson Lap Desk • CapShare Portable E-Copier • Low-temperature Glue Gun • CD Shrink-Wrap Opener • Fiskars Paper Trimmers • Sheaffer Targa Fountain Pen • File Philosophy

51 Eames Design • The Films of Charles and Ray Eames

## COMMUNITY

52 Blogging • Mark Frauenfelder

55 Really Useful Web Sites

56 Community Building on the Web • Webconferencing • Guerilla Wireless

## MEDIA

57 The Tipping Point • The Self-Made Tapestry

58 True Films • Kevin Kelly & Richard Kadrey

60 Netflix

61 Cheap Home Theater • B&W Magazine

62 Chased by the Light • Art Byte

63 Nausicaä of the Valley of Wind • Wacom Tablet

64 Digital Photography Kit • Shoebox Holography • Olympus Stylus Zoom 140



## LEARNING

65 The Ultimate Visual Dictionary • Open Here

66 Crystal Set Projects • Live Wire

67 The Way Things Go • Silly Putty • Zome System • Kid Pix

68 The Universal History of Numbers

69 Mathematics • The Complete Home Learning Source Book • Great Courses on Tape • You're Too Kind

70 Serious Play • All-Star Games

71 Robo sapiens • Nonzero • Finite and Infinite Games

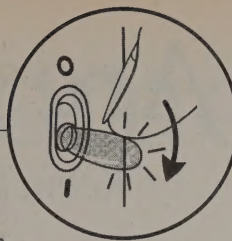

## Thinking With Your Hands

Maya Lin 72

An interview with the extraordinary artist/sculptor, and creator of the Vietnam War Memorial

## A Letter from Bangladesh, December 2050 83

The first-place prize winner from *The Economist's* essay contest on the world in 2050

## BOOKS AND RESOURCES

77 The Paper Propeller

78 The New Complete Guide to Vibrators • The Technology of Orgasm • President Barbie 2000

79 Organizing from the Inside Out • Sorehand • Repetitive Strain Injury

80 Dragonflies and Butterflies through Binoculars • The "Best" Binos

81 The Chicken Book • Extraordinary Chickens

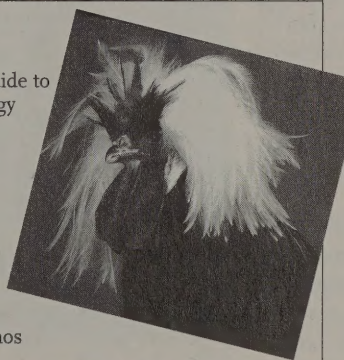

## BACKMATTER

85 Letters

88 Maniacals

90 Gossip

91 Updates • Bookbrawl

95 Readers Service

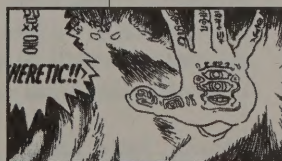

## Whole Earth

WINTER: 2000

Guest Editor Kevin Kelly

Guest Designers  
Kevin Kelly  
Deborah Tibbetts  
Stephanie Johnson  
Monika Olson

Editor Peter Warshall

Managing Editor  
Michael K. Stone

Assistant Editor  
Emily Polk

Contributing Editors  
J. Baldwin, Linda Connor, Dan Imhoff, Donella H. Meadows, Lyssa Mudd, Liz Thompson

Art Director  
Stefan Gutermuth  
Transcriber  
Robin O'Donnell

Associate Publisher  
Devon King

Bookkeeper Cynthia Ganey

Advertising Sales:  
415/256-2800, ext. 221.

Point Foundation Board  
Sunita Dutt, Diana Hadley,  
Robert Hillman, Hunter  
Lovins, Ron Pernick,  
Danica Remy

Founder  
Stewart Brand

Editorial Board  
Steve Barnett, Sue Hall,  
Wes Jackson, Jaron Lanier,  
Jerry Mander, Vijaya  
Nagarajan, Sharyle Patton,  
Godfrey Reggio, Wolfgang  
Sachs, Gary Snyder,  
Andrew Weil

Address all editorial and business inquiries to: *Whole Earth*, 1408 Mission Avenue, San Rafael, CA 94901-1971. E-mail: info@wholeearthmag.com.

**SUBSCRIPTIONS:** In US \$24; in Canada \$32 (includes postage and GST); elsewhere \$39 (US funds). For customer service, write *Whole Earth*, PO Box 3000, Denville, NJ 07834-3000, or call 888/732-6739.

*Whole Earth* (ISSN 0749-5056) is published quarterly by Point Foundation, a nonprofit educational organization, 1408 Mission Avenue, San Rafael, CA 94901-1971 (415/256-2800). Periodicals postage paid at San Rafael, CA and additional mailing offices. POSTMASTER: send address changes to *Whole Earth*, PO Box 3000, Denville, NJ 07834-3000. Copyright © 2000 by Point. Printed in USA.

www.wholeearthmag.com



# Tools Are the Revolution

Kevin Kelly, Guest Editor

Tools make revolutions. "When we make a new tool, we see a new cosmos," says physicist Freeman Dyson. He was probably thinking of microscopes, telescopes, and atomic particle accelerators.

But even the workaday tools reviewed in this issue can alter our perspective. A tool—any tool—is possibility at one end and a handle at the other. Because tools open up options, they remake us. A really fantastic atlas of the world (page 18) is literally a new world. A whisper-quiet ultra-efficient electricity generator (page 33) and a wireless Internet (page 56) let us see ourselves as more nomadic than perhaps we have seen ourselves lately. There are many ways to change the world, but I think the most direct way, the way being pioneered by artists, hackers, and scientists—third-culture citizens—is to adopt new tools.

This issue of *Whole Earth* is chock full of tools. Tools are meant broadly, as they should be: a piece of hardware, a video, a chart, a magazine, a gizmo, anything that opens up new paths. As usual, a tool is included here if it is a) the best, or the best bargain, b) easily available, and c) useful for self-education.

Presenting access to tools was the job of the original *Whole Earth Catalog*, a job that few other agencies were interested in at the time. A contemporary browser in a bookstore today would be astounded at how bare the shelves were thirty years ago. There was not a shelfful of books on, say, how to give a talk in public, as there is now; there was usually none. Thus the pointing, selecting, and reviewing the *Catalog* did was a vital, singular service.

It seems less so now. What happened? Among other things the Web happened. Today the world is awash in self-help, self-education, self-everything information. You can find any book in print online, and it's in your mailbox in days. Better still, you can find hard-won information on the most obscure passion just by clicking a little. Opening worlds is much easier. What this means is that the next edition of *Whole Earth Catalog* is here: it's the World Wide Web.

But still, something is missing. Something the *Catalogs* did, and this magazine still does, that is not found on the Web at large. It was in search of that missing component that I began this special issue. I suspected that one function the *Catalogs* offered that is not being provided by the Web is to highlight the best.

As the Web expands in scope to include everything, the best gets overwhelmed. Even great search engines and great recommendation software can't provide what I really want. I use the best recommendation sites, and decent though they are, they don't give me what I really want. I want someone I trust to say to me: "I've seen all the stuff, and I've used most of it, and this is the one you want." I don't usually find that on the Web. First, trust is in short supply, and second, comparative evaluation is in short supply. As working on this issue reminded me (it's been ten years since I edited the magazine), making confident claims like this is hard, time-consuming, and expensive. It's not done

casually, although we try hard to make it appear so.

I have no idea whether this kind of handcrafted evaluation service can scale up to cover the Web as a whole. Far less labor-intensive services are failing as commercial Web sites; what hope would there be for a time-intensive process that tried to keep up with everything? I have no idea what the future of *Whole Earth* is, whether it can keep going in the midst of the Web. (Luckily, I'm just a *guest* editor.) I do know there is an urgent need for directing people to the best and most appropriate in tools, a need that does not diminish as more tools are created, but rather expands as more ho-hum tools are available.

It was a blast putting together this issue. In the spirit of the first *Catalogs*, this is a home-brew self-published deal. To keep things simple and maximize learning I was the major reviewer, fact-checker, typist, scanner, designer, and layout person. I had no staff. If you notice an unusual level of funkiness in this issue (like jaggedy pictures swiped off the Net) that's all due to my amateur skill level. Not that I didn't have professional help. Paul Donald, Deborah Tibbetts, Stephanie Johnston and Van Burnham provided production advice and the crew at *Whole Earth* proofed and saved me from embarrassment.

I learned a lot. One thing sticks out: the tools of self-empowerment that were yearned for decades ago have been instituted on a mass scale. Those tools—based on digital power and the web—are now widely available to almost anyone in the developed world. We can do many of the things we once dreamed of doing. The revolution is new tools.

But tools (technologies) create their own new problems (too many possibilities, too many passions, too much demand for knowledge). I view the problems created by technology as simply opportunities for new tool making. That's the Great Circle that keeps going round: new tool, new problems, new tools. That circle would be mere running in place if it were not for one fact: each round of the circle expands with more options. Technology and tools create as many problems as they solve. What's good about that, you say, even if it is expanding? That's the usual critique of tools, but I think there is an answer. Tools and technology create only one purely positive thing: their expanding circle creates ever more possibilities and choices. That's pure good. More choices are always good. I'm pro-choice.

The most revolutionary tools are those that expand the choices inherent in other tools. To the three criteria for evaluating tools in *Whole Earth*, I'd like to add a fourth: a good tool is one that launches a cascade of new opportunities. I hope there are some of those in this issue.

Thanks, Peter, for the opportunity to try something different here. Readers can direct personal feedback to me (kk@well.com); news of benefit to all readers—updates, corrections, new suggestions—should be sent to editor@wholeearthmag.com.



# A Tool For Tomorrow

It was Danny Hillis's idea to build a clock that would tick once a year, tock once a century and gong every millennium. By slowing down the usual speedy movements of a clock, he hoped to slow us down and have us think about the long term.

"Long term" to Danny meant about 10,000 years, which, it happens, is about the same length of time as human culture has been ascendant. He wanted to look ahead into civilization about as far as we can look back.

The purpose of a clock that runs for 10,000 years is to encourage us to create things that require 10,000 years to measure. A great civilization, for instance. Or anything we hope to last three generations and beyond.

Just the idea of such a clock can liberate our notions of time and purpose; perhaps we would not have to actually build one. It could be a thought experiment, a specimen of conceptual art.

But the difference between the thought of a 10,000-year clock and really building one is the same difference between the idea of a solid 500-foot pyramid and actually hauling stones to erect one. A society that built a clock running for a century of centuries would have to really believe in the power of the future.

Part of the purpose of building a millennial clock is to move our society into this position, so that it can confront its future while keeping in mind its past.

Stewart Brand took up Danny's fantasy, and tried to make it real. The best way to move society into the position of seeing the value of the clock, and thus the value of the long-term responsibility, would be to start building the clock now. Tomorrow if possible. As the clock became real, so would the perspective.

With Stewart's encouragement, Danny began to design the clock. I joined them to tip the critical mass of believers to a safe three, since if three people back an incredible idea it begins to seem credible. Stewart roped other remarkable people into the conspiracy and then hired the brilliant and refreshingly young Alexander Rose, who, more than anyone else, made the thought experiment real.

More of the impetus for building the clock is described at length by Stewart in his book, *Clock of the Long Now* (see *Whole Earth*, Winter 1999). In the spirit of delving into how tools enable a revolution, Danny describes his design process on the following pages.

Adding further reality to experiment, the Long Now

Foundation (the nonprofit set up to run the mission) has bought a mountaintop in Nevada completely enclosed by a national park as a home for the clock—far from the turbulent effects of a city. The plan as of now is to put the great clock inside the mountain, to be the unforgettable destination of a pilgrimage up the mountain. For more information, contact [www.longnow.org](http://www.longnow.org). —KK

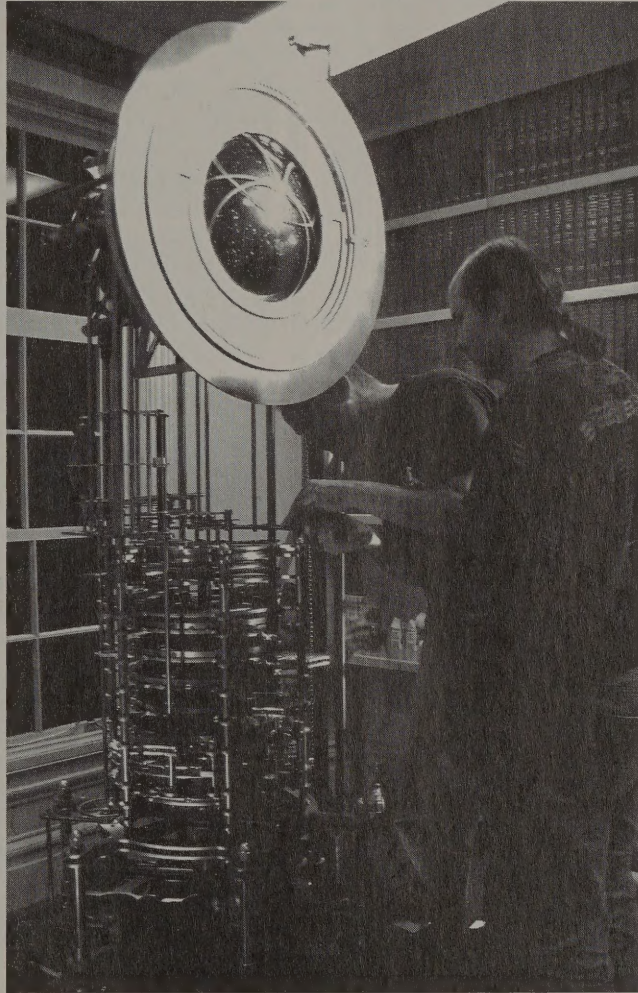

Danny Hillis, far right, oversees the final tuning of the prototype clock on New Year's Eve, 1999. Alexander Rose adjusts the mechanism so that in a few hours it will trigger a gong—twice—to ring in the new millennium. It worked.



# How to Design a 10,000-Year Clock

*Danny Hillis*

One of these days Danny Hillis will find the inner adult in himself. For now, Danny has a constant child-like curiosity about how things work, and a seriously playful manner in making new things. He's invented supercomputers, coded his business card into DNA, made a walking dinosaur for Disneyland, and, together with another boy wonder, Bran Farren, has gone into business as the appropriately named Applied Minds. In the past couple of years Danny has applied his mind to a clock. This project has all the hallmarks of a Danny Hillis idea; it's original, just barely feasible, and changes how others think of the world. —KK

OBVIOUSLY, NO ONE CAN GUARANTEE a 10,000-year lifetime for any clock. But the design of some clocks guarantees that they won't work for 10,000 years. For example, a clock that shows a four-digit year date will not work after the year 9999. I believe you can design a clock that, with continued care and maintenance, could reasonably be expected to display the correct time for the next 10,000 years. Whether or not it is reasonable that such a clock would actually receive care and maintenance for such a long time is another question, but even in this respect there are things we can design in to help it get that attention.

I chose 10,000 years as the plausible outer limit for the endurance of human-made things. We have technological artifacts such as fragments of pots and baskets that are at least 10,000 years old, so we have some precedent for a human artifact surviving this long.

While all clocks have design trade-offs, a 10,000-year clock has a unique set of design considerations:

A clock with a 10,000-year longevity implies that the mechanisms of the clock should move slowly, so that parts do not wear down, at least to the point of being inaccurate. After all, 10,000 years of tick-tocks is a lot of wear and tear. Even better would be to avoid ticking altogether, since a tick is really the bang of metal slamming into metal—something one would like to avoid over such a long run. If the clock must tick, it should do it infrequently. Longevity also implies that the design must withstand occasional earthquakes, and unusual extremes of outside weather, and if possible be kept clean and dry.

The corollary to longevity is maintainability. Most things last only if they are easy to care for and encourage stewardship. The greatest temptation in building something that will last a long time is the urge to build it using the newest technology. Paradoxically, the only technologies we are sure will work over a long time are...technologies that have been around for a long time already! The only technologies that can be relied upon to be around for a long time in the future are old ones that have been

around a long time in the past. Electronics, for example, is not a safe bet for a 10,000-year duration, because on a 10,000-year time scale, it may be a passing fad. A prudent design demands the use of familiar materials, and proven, simple technology.

Another requirement for long-term maintainability is transparency. That is, it should be possible for an intelligent person to determine the operational principles of the clock by close inspection. This is another reason to rule out electronics, because if knowledge of electronics were lost for whatever reason, an electronic clock could not be understood without special tools; its operation and maintenance would not be transparent.

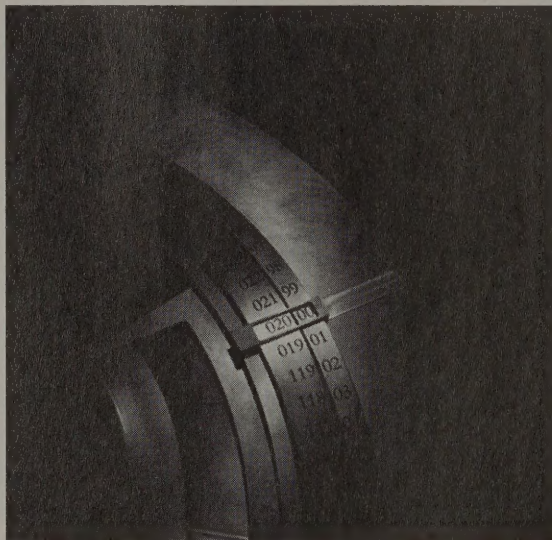

If the clock is ever stopped, it should be obvious how to restart it and set it to the right time. Diagnosing problems should be possible without special tools or esoteric knowledge, and it should be easy to build spare parts. Instruction manuals inevitably get lost (even in a few years!), so any information required to repair or restart the clock should be obvious from inspecting the clock itself. A major way to keep the technology transparent is to use simple technology and an open design that is understandable to anyone who comes upon it.

A study of history shows that things which last a very long time—such as great buildings—endure in part because they can be continually updated to meet current needs. The oldest clocks still going have been continually modified over time. In short, long-lived things evolve. Requirements change. New ideas are invented. The best designs accept changes with grace; those destined to be left behind are too rigid to modify. Therefore, the clock should be able to improve with time.

The final design requirement for a hundred-century clock is scalability. For aesthetic and technical reasons, we would like to build a very large clock, say something that is 40 feet high. But this is both expensive and difficult technically. One way to build a very big clock is to build a series of prototypes that start out small and



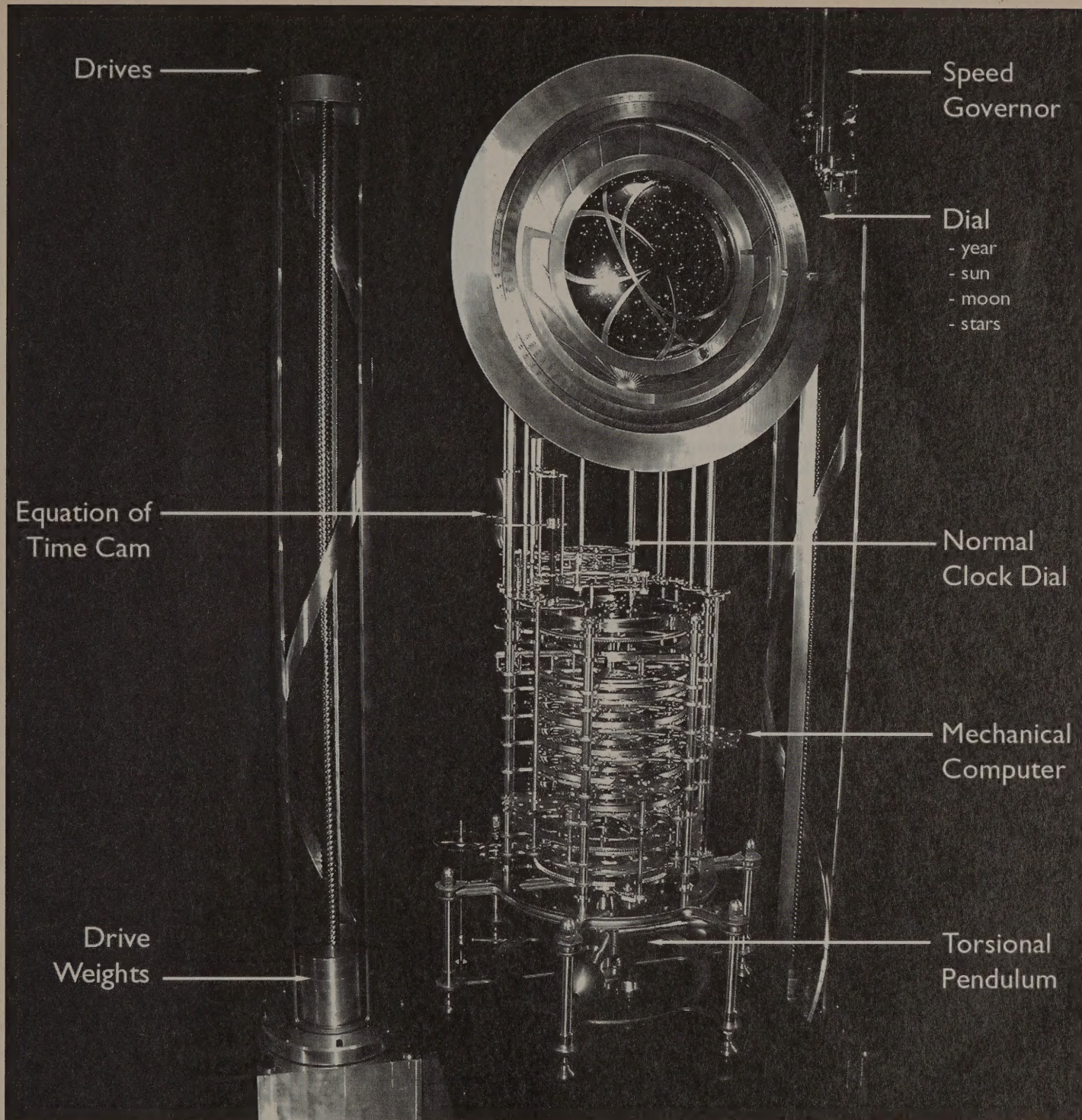

get bigger each time you build the next version. This allows you to do the initial experiments (and make mistakes) on a smaller, more affordable scale. But this also means coming up with a design that works both at the scale of a working model on a tabletop and at the scale of one weighing many tons. This is actually not easy to do because when small parts are made very large and massive they behave differently, even though they are the same shape.

Almost any clock has four components: 1) a display, 2) a timing element, 3) a converting mechanism, and 4) a power source. The

display is the part that indicates the output of the clock to the users, the part you look at to see what time it is. This may be a dial with hands, a chime, or something more elaborate. The timing mechanism is usually some form of tuned oscillator, such as a pendulum, a balance wheel (which rotates back and forth), or a quartz crystal (which vibrates). The converting mechanism transfers the timing signals from the oscillator mechanism into the display. In most mechanical clocks and watches a "train" of gears does this transfer. Finally, any clock needs a source of power, such as a wound spring or a battery.



I considered many different options for the power source of the clock. Here are the ones I evaluated and why I rejected them, based on the design requirements above:

<b>atomic power</b>	<i>poor maintainability &amp; transparency</i>
<b>chemical power</b>	<i>poor scalability</i>
<b>solar electric cells</b>	<i>poor maintainability &amp; transparency</i>
<b>very big spring</b>	<i>poor scalability</i>
<b>water flow</b>	<i>exposure to water</i>
<b>wind</b>	<i>exposure to weather</i>
<b>geothermal power</b>	<i>poor scalability</i>
<b>tidal gravitational changes</b>	<i>poor scalability</i>
<b>seismic and plate tectonics</b>	<i>poor scalability</i>

Several systems based on temperature or pressure change seemed feasible, but in the end I decided the best system was to require regular human winding. This may seem an odd choice, but remember that the clock design already assumes regular human maintenance. Winding the clock fosters responsibility.

Over hundreds of years of clock making, inventors have devised scores of methods for timing clocks, providing me with a huge list of possible timing mechanisms. But for a 10,000-year clock I had to reject most of them for the following reasons:

- pendulum (*inaccurate over the long term, requires lots of ticks*),
- balance wheel (*even more inaccurate*),
- a torsion pendulum (*potentially slower, but even less accurate*),
- water flow (*inaccurate and wet*),
- solid material flow, like sand (*inaccurate*),
- daily temperature cycle (*unreliable*),
- seasonal temperature cycle (*imprecise*),
- tidal forces (*difficult to measure*),
- Earth's rotating inertial frame (*difficult to measure accurately*),
- stellar alignment (*unreliable because of weather*),
- solar alignment (*unreliable because of weather*),
- atomic oscillator (*not transparent, difficult to maintain*),
- piezoelectric oscillator (*not transparent, difficult to maintain*),
- atomic decay (*difficult to measure precisely*),
- wear and corrosion (*very inaccurate*),
- rolling balls (*very inaccurate*),
- diffusion (*inaccurate*),
- tectonic motion (*difficult to predict and measure*),
- orbital dynamics (*difficult to scale*),
- tuning fork (*inaccurate*),
- pressure chamber cycle (*inaccurate*),
- inertial governor (*inaccurate*),
- human ritual (*too dependent on humans*)

After evaluating all these possibilities I concluded that no single source of timing met the requirements of a 10-millennium clock. Either the mechanism was accurate over a time, but could easily stop (unreliable), or it was reliable over the long haul, but not very accurate in the short term. My solution was to use a slightly unreliable timer to adjust a slightly inaccurate timer; these two imperfect timing mechanisms together produced something nearly perfect. Specifically, the current design uses solar alignment of the noon sun (accurate but unreliable) to adjust a slow-torsional-pendulum mechanical oscillator (reliable but inaccurate). The combination in the clock provides both reliability and long-term accuracy.

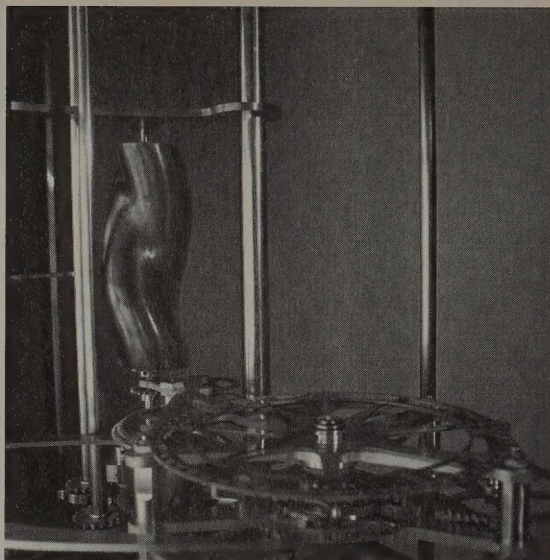

The Equation of Time. This piece is a physical representation of the shift over centuries of the Earth's tilt with respect to the stars. A pointer resting on the surface slides up over time while the Equation of Time rotates each year. In this manner the correct Earth time is maintained.

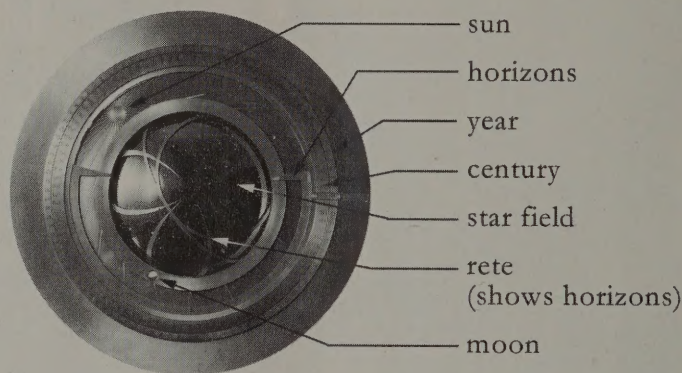

Choosing a display was also a tricky question. Many of the usual units displayed on clocks, such as hours and calendar dates, are likely to have little meaning 10,000 years from now. On the other hand, every human culture we know counts days, months, and years. There are also longer natural cycles, such as the 26,000-year precession of the Earth's axis. On the other hand, the clock is a product of our time, and it seems appropriate to pay some homage to our current arbitrary systems of time measurement. In the end, it seemed best to display both the natural cycles and some of the current cultural cycles. The center of the clock shows a star field, indicating both the daily rotation of the stars in the sky, and the 26,000-year precession as it migrates across the zodiac. Around this center circle is a ring showing the position of the sun and the moon in the sky, as well as the phase and angle of the moon. Encircling this is the ephemeral dial, showing the year according to our current Gregorian calendar system. But our current convention of using four digits is inadequate for a 10,000 span, so this clock has a five-digit display, indicating the current year as 02000. Not so prominent, hidden inside the clock, is a small conventional dial displaying the hours and minutes, in

More information and pictures of the prototype can be seen at [www.longnow.org](http://www.longnow.org). This essay was adapted from a note previously published in the *Horological Science Newsletter*.



case you actually wanted to know what time it was to the minute.

I considered various schemes for the part of the clock that converts time signals to display units. These included electronics, hydraulics, fluidics, and mechanics. One major problem with using a conventional set of gears is that gears have a ratio relationship between their input and output. Precisely how fast a big gear can turn a small gear depends on the accuracy of the ratio of their relative sizes. If their relative sizes are off a little, their speed, and thus the clock's timing, will be off. The required accuracy of the ratio increases with the amount of time the clock is measuring. For instance, if the ratio of gears of a clock produces 29.5 days per lunar month; that's okay for a short period of time, but over 10,000 years the number 29.5305882 is a much better choice. Achieving such precise ratios with gears is possible, but awkward.

The key innovation of the 10,000-year clock is that instead of gears it uses binary digital logic, implemented mechanically. (There are gears in the clock, but they are not used for counting.) Ordinary mechanical clocks take the timing signals from the oscillator, and use gears to count the ticks and then turn the clock's hands moving over numbers. In the 10KY clock, the counter is not a bunch of gears, but a simple digital computer. But this digital computer is mechanical, not electronic. To be more precise, the mechanism that converts the timing signal to the dial output is a digital differential analyzer, implemented with mechanical wheels and levers instead of the more usual electronics.

This mechanical-digital computer uses a 27-bit number representation, with each bit represented by a mechanical lever or pin that can be in one of two sliding positions (thus binary). There are about 300 bits in the machine. There is a complicated "adder" that slides over the bit pins and moves them (or not), almost like someone using an abacus. The adder tallies up the timing signals and delivers the result to other pins, which eventually—at the correct count—trigger the advance of the dial, or, every 1,000 years or so, the ringing of a gong.

Another advantage of the digital computer over the gear train is that it is more evolvable. For instance, the ratio of day to year depends on the Earth's rotation, which is slowing at a noticeable, but not very predictable, rate. This drift, for example, could be enough to throw off the phase of the moon by a few days over 10,000 years. The digital scheme allows the day/year ratio to be adjusted easily—just move some pins. To do this with gears would require re-engineering and re-cutting the gears, essentially making it unlikely to ever happen.

In 1999 we constructed a small prototype of this clock, approximately two meters tall. At midnight on New Year's Eve, at the conventional turn of the century, the date indicator on the face of the clock changed from 01999 to 02000. The chime struck twice, to ring in the second millennium. A small crowd of builders and supporters were on scene to celebrate this first chime. (It will be another 1,000 years before the descendant of this clock chimes again.) The prototype is currently on display at the London Science Museum in a permanent exhibit where it stands among legendary prototypes of the past, such as Babbage's Difference Engine, and Watson and Crick's first model of the DNA molecule.

Alexander Rose has been my primary collaborator on this project. The other members of the design team for this prototype are David Munro, Elizabeth Woods, and Chris Rand.

While this prototype is currently functioning as a clock, not all its elements are completed. For instance, an early version of the solar sensor adjuster has been constructed and tested, but it is not yet integrated into the clock.

We are currently designing a second prototype, which will be about twice the size—18 feet tall. Some of the design details will shift as we improve it and increase its mass. We are aiming to build the great clock at 40 feet; its pendulum bobs alone would weigh about 200 pounds each. The rings holding the pins would be about 20 feet across. The fantasy is that you could walk inside the clock as it slowly, slowly, slowly counts the days toward the year 10,000.

---

## Changing the World

Like much of my generation, I grew up believing that I should try to "change the world," presumably for the better. But I didn't know how to do this. Looking at how other people have changed the world I concluded there are five ways of doing it:

- Some people change the world by imposing their will on it.
- Some people change the world by discovering a truth.
- Some people change the world by changing people's minds.
- Some people change the world by creating things of great beauty.

- Some people change the world by making new tools for change.

Although I can admire all of these, the last mode of changing the world is the one that appeals to me the most. As a dramatic example of changing the world by making new tools, I include the creation of the Internet. I would also list something like building the rural credit system in Bangladesh as another example. Changing the world in this way can involve changing people's minds, and can entail imposing one's will to some extent, but it is mostly about enabling other people to change—by giving them tools to do so. This feels like progress.

The other appeal of tool creating is that change brought about this way is self-sustaining and self-correcting. By self-sustaining, I mean you can use tools to make

other new tools. This gives enabling tools a self-amplifying effect that can gain importance with time. I like that. I feel this is a very different way to change the world from trying to impose your will on it, because when you do that the world tends to snap back after you stop trying, or after you leave. Also, enabling change through tools is self-correcting. People who try to change the world by imposing their will on it often cause unintended harm, because the consequences of the change are hard to predict. When the beneficiaries control the change themselves, they have a lot more opportunity for feedback. Thus, change of this sort has a better chance of being good.

I still want to change the world, but now I know how I want to do it: by making new tools for change.

—Danny Hillis





## THE ROSETTA DISK

*Another tool project by the Long Now Foundation*

### PAY IT FORWARD

WHILE IT HAS BECOME trivially easy to duplicate information within time—to make millions of copies of things at once—it is still immensely difficult to duplicate information over time—to make sure a copy of something will last centuries or longer. Paradoxically a digital format decreases the longevity of information because digital platforms obsolete so quickly. All the stuff you stored on floppy disks will be unreadable shortly. In a hundred years from now CDs will almost certainly be unreadable because of the presumed widespread lack of operating CD players (think 78 records and eight-track tapes).

Civilization is a tool for remembering, for bringing what was learned in the past into the future. Civilization was hatched by the technology of writing and its attendant technologies of book, index, and library—all meant to keep ideas and information alive over time. Books printed on acid-free paper and stored on shelves do this well. However our expectation of what a book can do has not stood still. The full content of a book—not just its title—must be deeply linked with all other texts and supremely searchable. Any book not on the Web almost doesn't exist now. Thus we are on a campaign to digitize books as fast as we can. But with the proliferation of digital media, and their increasingly short life cycles, maintaining a digital book's knowledge over long periods of time is a new, and vital, problem. The Web itself is no solution. Brewster Kahle, a pioneering archivist at the Internet Archive, has been making the sole backup of the Web. If it goes down (and some publishing and broadcast companies would like it to stop because they consider the backup to be a copyright infringement), then there goes contemporary civilization's only archive.

The Long Now Foundation has been exploring solutions to this problem. Together with the Getty Museum it hosted a "Time and Bits" conference, gathering experts in the conservation of literary and art materials along with computer scientists to ponder how to

conserve digital material over millennia. From that meeting emerged the idea of a 10,000-year library, an institution dedicated to the care and exercise of materials for the very long term. As a first step toward the goal of developing a millennial library, the Long Now Foundation secured funding from the Lazy Eight Foundation to create a prototype of a very long-term storage device. The aim of the prototype is to take a fixed amount of text and embody it in a device that could reasonably be expected to be readable and understood 10,000 years from now.

A number of immediate challenges surface when the problem is stated in this way. What language should the text be in? What format? What material should be used? And what should the content say? The actual goal was a 10,000-volume library, in fully searchable, indexed, multi-linguaged text that would endure a thousand centuries and be readable even if civilization somehow forgot, or gave up, digital technology.

That clearly was too ambitious to start with, so Doug Carlston, co-founder of Broderbund software and Long Now board member, suggested a doable first project as a rehearsal for the grander scheme. His idea: find the most translated texts in the world, gather all the translations and put them all on one super-durable disk. Because all the translations would be parallel the disk could serve as a Rosetta disk. If in the far future a text in a long-forgotten language should be found, there would be at least one source (the 10K Rosetta disk) etched into a noncorroding material that would contain clues to deciphering it. Achieving this modest goal would also teach us a lot about how to do a larger library.

The most translated text in the world at this time is the Bible, in particular the first three chapters of Genesis. The start of Genesis ("In the beginning") is translated into thousands of languages and scripts, and as a bonus, most of these translations were housed in a few institutions. Jim Mason, a young artist with a background in languages and anthropology was hired by Long Now to research and design a 10K Rosetta disk. He imagined a tangible object that would say: read me, keep me forever.

Here is Jim's report on the current status of this project.

*We are attempting to create a modern "Rosetta stone" using a new extreme-longevity, high-density analog storage technology. The makers of this storage device, a three-inch micro-etched nickel disk, estimate longevity in the 2,000–10,000-year range. Our goal is to create a functional translation engine for 1,000 world languages as well as an aesthetic object that suggests a journey of the imagination—a tool that both enables and inspires communication between distant historical moments and diverse cultural worlds.*

*The Rosetta disk expands on the parallel text structure of the original Rosetta stone by archiving five distinct linguistic components for each language on the disk. We have selected these five components as the "minimum representation" necessary for a meaningful recovery of a lost language and/or writing system by future linguistic archaeologists. These components are:*

- 1. Main parallel text: We are using the widely translated Genesis Chapters 1-3 for the main text.*
- 2. Indigenous creation myths of each region, including the contemporary creation stories of the Big Bang and human evolution. Each story has an interlinear gloss (grammatical breakdown and analysis).*
- 3. Core vocabulary list.*
- 4. Orthography: The writing system(s) and scripts of the language with pronunciation guide.*
- 5. Metadata for each language: origin and current distribution of language, number of speakers, linguistic family, typology, and history, etc.*



We have selected an extremely stable, nano-scale, analog storage system as an alternative to the quick obsolescence and fast material decay rate of typical digital storage systems. This technology, developed by Los Alamos Laboratories and Norsam Technologies, encodes analog text and images on a 3" nickel disk at densities of up to 350,000 pages per disk. Since the encoding is analog (no 1's or 0's), there is no platform or format dependency, guaranteeing readability despite changes in digital operating systems, applications, algorithms, etc.

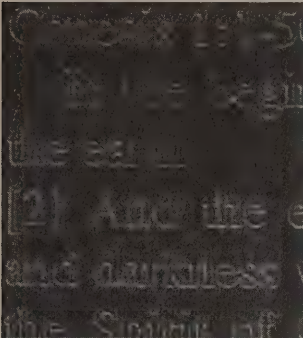

The letter "G" is 3 microns across. At this scale one disk can hold 4,000 pages.

Reading the disk requires a microscope, either optical or electron, depending on the density of encoding. The current

version of the Rosetta disk will only require an optical microscope to read. The scan can be combined with a typical Optical Character Recognition system to read the text back into digital formats relevant at the time of reading.



Our current design consists of an Earth image at the center with spokes radiating outward holding 27,000 language data pages, twenty-seven pages for each language. An external band of Genesis texts in eight major world languages (English, Russian, Hindi, Spanish, Hebrew, Mandarin, Arabic, and Swahili) begins at eye-readable scale and slowly tapers down to nano-scale. The design implies the operating instructions: "Get a magnifier because there is more."

The prototype disk is mounted in the center of a 4-inch diameter sphere made of optical glass and stainless steel. Inside the bottom metal hemisphere we have created a hollow cylinder that holds a stainless steel ribbon for disk caretakers to etch their names, locations, and dates—hopefully creating a unique pedigree for each Rosetta object as it travels through time and human hands.

Right now only one copy of the Rosetta disk exists. Ideally tens of thousands of them should be seeded throughout the world as a

means to insure the continuation of their content into the far future. That's one way to keep it alive.

There are four major approaches for keeping things very long term: hide them (Dead Sea Scrolls), make them large and indestructible (pyramids), religiously care for them (relics), or make lots of copies and hope for the best. This last strategy is called LOCKS (Lots of Copies Keep 'em Safe) and it seems the most likely approach for digital information.

But LOCKS doesn't always work. The modern time capsule was invented by Thornwell Jacobs, an educator, minister, and amateur historian in Georgia in the 1930s. Jacobs was disturbed by his studies of ancient biblical history because so much of past records has disappeared. If only people back then had had the wisdom and foresight to keep essential materials for later historians (like him) to study, how much richer our understanding of the world (and religion) would be now. But wait, Jacobs, realized, our time is no better! We also are not considering future historians. We are not deliberately conserving knowledge in a form that would make it easy for them to retrieve and study. If we are so civilized shouldn't we scientifically archive material for the future—and not just the official texts?

Jacobs decided to send to the future as much of civilization as he could squeeze into a large sealed vault. He called it the Crypt of Civilization, a living room-sized underground tomb, and he stuffed it full of encyclopedias, classics, film clips on metallic film, wordless instructions, and a trove of folkloric ephemera and cultural knick-knacks. Figuring that there has been about 6,000 years of history, Jacobs set the opening date approximately 6,000 years into the future, or 8113 to be precise according to his ideas of when civilization actually began (4241 B.C.E.). By predefining the opening date, in contrast to treasures hidden in walls and vaults meant to be opened in some accidental time, Jacobs invented a time capsule. (One of his associates took Jacob's idea to the Westinghouse company and got them to build and bury a time capsule several years before Jacobs could finish his own; thus the world remembers the Westinghouse World's Fair one in 1939 as the first time capsule.)

Inspired by the Westinghouse time capsule, every year families, schools, towns, and corporations seal about 100,000 small time capsules in the US. Almost 95 percent of them are lost track of and forgotten in ten years. So how will the world remember the buried Crypt of Civilization in 6,000 years?

Jacobs's solution was a version of LOCKS. He created a book about the Crypt, which was to serve both as an operating manual and as a reminder. The book tells the exact longitude and latitude of the Crypt (under part of Oglethorpe University in the northern outskirts of Atlanta, Georgia), and how to figure out longitude and latitude if both the borders known as Atlanta and the convention of longitude should disappear. Jacobs then made lots of copies of the book, and sent them to libraries around the world, including a few monasteries in Japan and China. The shocking surprise is that after only fifty years or so there are only two known copies of the book.

Forwarding material into the future is difficult. We have lost more texts of the ancient Greeks than we have kept. Manufacturing something to endure thousands of years is only part of the problem. Anticipating changes in language and context is also only part of the problem. Sustaining care is the hard part.

The Rosetta disk, in conjunction with the 10,000-year Clock, is one attempt to develop tools that will provide our technological civilization with a long-term memory. That's a big job that will require many more ideas. For more information, contact [www.longnow.org](http://www.longnow.org).

—Kevin Kelly



## ExactSet Travel Clock

Computer clocks drift. Hotel room clocks drift notoriously. Hotel wake-up services sometimes fail. The securest solution I've seen is this new digital travel clock from Oregon Research. Several times a day it reads the EXACT time by radio from official transmissions and sets itself accordingly. Convenient for travel, it can be set to the four US time zones with a simple push button and a tiny display map. It has a lock switch that immobilizes the controls against suitcase impacts. Tapping the clock illuminates the display; a tap also turns off the alarm when it is ascending through its squeaky crescendo. It automatically adjusts to daylight savings. The clock unfortunately has microscopic instructions translated from Urdu and less-than-intuitive button controls, but the confidence it gives is worth the inconvenience. Unlike my previous travel clocks, between trips I keep this one active on my desk.

—Stewart Brand

## Oregon Scientific ExactSet Travel Clock

\$50

From, for example:

weathertools.com

800/826-5708

www.weathertools.com/oregon/rm826.htm

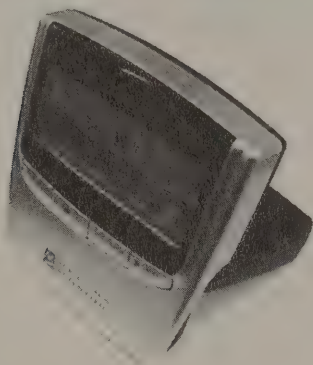

## Analog Atomic Wall Clock

Like most households we have lots of precise clocks and watches, but none of them are set to the right time (I think). With constant advancing or retreating because of travel or daylight savings, no timepiece is safe from being infected with inaccuracy. (Who has time to call for time?) Most clocks and watches linked to the exact time from Boulder, Colorado, are digital, but I'm an analog man. The 12" Atomic Wall Clock is large, analog, and self-correcting. (It's like having an atomic clock in your basement.) It's spooky to watch the hands whirl around until they find their spot as it adjusts itself in and out of daylight savings time, a chore worth at least its price. Someday all clocks and watches (and appliances!) will be this smart.

—KK

## 12" Radio Controlled Clock

\$50

From, for example:

Edmund Scientifics

800-728-6999

www.scientificsonline.com

or 877-627-9029

www.atomic-clocks.com; they have all kinds, including watches.

## IWC Fliegerchronograph Watch

Designed decades ago for pilots, this big wristwatch is instantly readable at any distance in any light, including the middle of the night under covers four inches from my farsighted eyes. It tells day of the week as well as date. It's happy under water. Its chronograph precisely measures duration up to twelve hours, readable to fractions of a second. And it's "automatic," meaning that my activity enables its activity, batteries not needed. It is expensive—around \$3,400 street price. I made the jump because my \$40 Swatch was keeping my wife awake with its loud, slow tick. The IWC ticks so fast and quietly, you barely hear its whirl when you press it against your ear. It's a lifetime watch, though cleaning is needed every five years or so. I got the black ceramic case for its understatement. Magpie-eyed thieves don't even notice it.

—SB

## IWC Fliegerchronograph Watch

Around \$3,400 from:

www.ashford.com

Cheaper on

eBay at times.

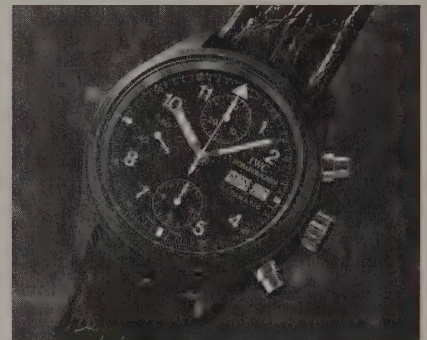

## Correlated History of Earth

The long view. Or rather, views. Geological time and biological time run at such different paces that the two perspectives are not easily brought together. This crisp chart joins them with extraordinary clarity. It lays out the chronologies of continents skittering around the globe, of comet and asteroid impacts, and of life's increasingly diverse groups of living creatures and how they fit into geological time. And more. Ordinarily, combining such staggering amounts of information would yield mush and muddle. But this exquisitely printed, laminated poster manages to present 4.5 billion years of geology and biology as the unified whole that it is. Like a good map it teaches something at two feet away, or you can get out a magnifying glass and read down for details.

—KK

## A Correlated History of Earth

Pan Terra

1999, 28 x 38 inches

\$25 postpaid

Pan Terra Inc.,

PO Box 556,

Hill City, SD, 57745

605/574-4760

www.wmnh.com/wmgsche.htm

Actual size

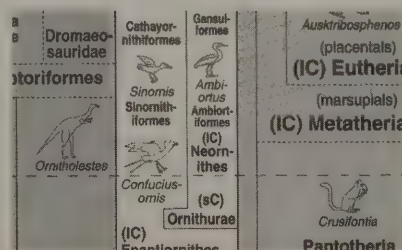

From the chart's Web site:

"Included are plate tectonic maps, mountain building events (orogenies), major volcanic episodes, glacial epochs, all known craters from asteroid and comet impacts, over 100 classic fossil localities from around the world, fossil ranges of plants, invertebrates and vertebrate life forms, and major extinction events as revealed by the fossil record. Also evident on this chart are the "Cambrian explosion" of animal phyla and the juxtaposition of reptiles and mammals across the Cretaceous/Tertiary (K/T) boundary. Hundreds of illustrations add a striking visual dimension to the data."

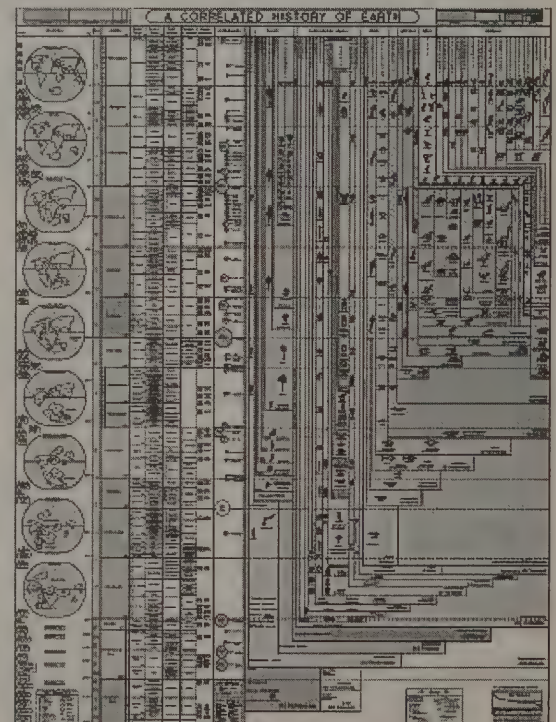



# Histomap of World History

Not a map really, but a 6-foot-high chart showing in one glance 4,000 years of human history on a global scale. Thirty years ago I saw this on the wall of someone's dorm room and it flipped me out then, and every time I've seen it since. Its beauty is how Mr. Sparks divvies up world power (somewhat crudely) into its main factions graphed in each increment of fifty years since 2000 B.C.E. Different civilizations are color-coded so one can easily trace the flow and ebb of culture over the centuries.

It has three uses for me: whenever I am reading about some historical event I can instantly see what else was going on in the world at that time (for instance, what was happening in France during the Ming Dynasty). I also get a very intuitive sense of the rises and falls of civilizations, a pattern that no other chart or book has been able to give me. And hanging on the wall, it never fails to elicit gaps of shock when visitors recognize our modern place in the chart. At seven bucks, it's a bargain education.

—KK

## Rand McNally Histomap of World History

John B. Sparks  
1952, 48 x 12 inches  
\$7  
Rand McNally

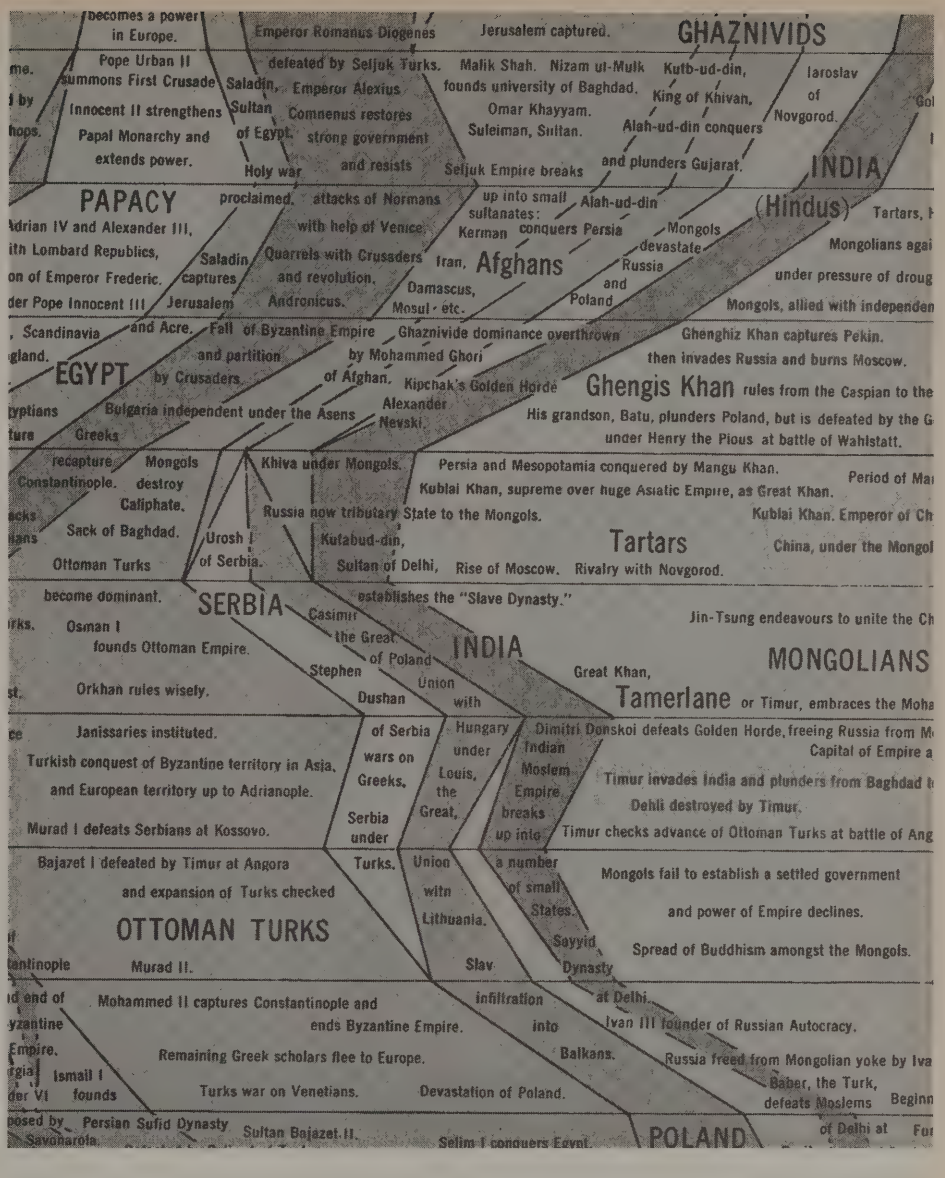
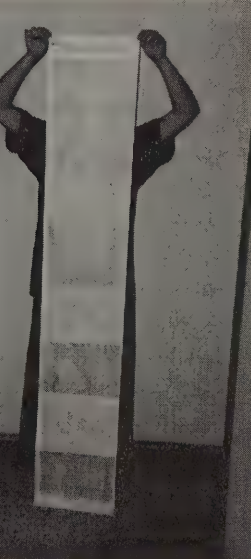

## Chronicle of the World

A timeline of history, delivered in headlines. USA Today-style front-page stories and color photos debrief each year since 1000 (or each decade in the first millennium). Rather than being corny, this brevity and intimacy quickly gives context.

—KK

## Chronicle of the World

Derrick Mercer, editor  
1996, 1,175 pages  
DK Publishing  
Currently out of print

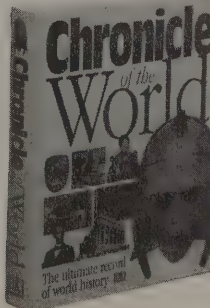

## Massacre follows fall of Baghdad



A last Arab picture of Baghdad.



An upsurge of a battle's eye view of the city of Baghdad.

...at the edge of the rubble and destruction and had walked into a hole a crane of the rubble. It was based on the depiction, who first brought the gold pillars of the Hanbury. He was soon joined by three and millions as well. The crusaders are supposed to be marching toward the Holy Land, and Janib bin said them that the sea will part for them so that they can walk all the way. Whenever they are slain as a nation. He is said to be the sea. He claims that their food will never grow, and the leaves and fishes. He marries followers if they want it, and devotes them to. He even had many martyrs among powerful people.

...at the edge of the rubble and destruction and had walked into a hole a crane of the rubble. It was based on the depiction, who first brought the gold pillars of the Hanbury. He was soon joined by three and millions as well. The crusaders are supposed to be marching toward the Holy Land, and Janib bin said them that the sea will part for them so that they can walk all the way. Whenever they are slain as a nation. He is said to be the sea. He claims that their food will never grow, and the leaves and fishes. He marries followers if they want it, and devotes them to. He even had many martyrs among powerful people.

878

...of the city of Baghdad. It was based on the depiction, who first brought the gold pillars of the Hanbury. He was soon joined by three and millions as well. The crusaders are supposed to be marching toward the Holy Land, and Janib bin said them that the sea will part for them so that they can walk all the way. Whenever they are slain as a nation. He is said to be the sea. He claims that their food will never grow, and the leaves and fishes. He marries followers if they want it, and devotes them to. He even had many martyrs among powerful people.

### Alfred repels the Danes

...of the city of Baghdad. It was based on the depiction, who first brought the gold pillars of the Hanbury. He was soon joined by three and millions as well. The crusaders are supposed to be marching toward the Holy Land, and Janib bin said them that the sea will part for them so that they can walk all the way. Whenever they are slain as a nation. He is said to be the sea. He claims that their food will never grow, and the leaves and fishes. He marries followers if they want it, and devotes them to. He even had many martyrs among powerful people.

### Indian king killed, kingdom annexed

...of the city of Baghdad. It was based on the depiction, who first brought the gold pillars of the Hanbury. He was soon joined by three and millions as well. The crusaders are supposed to be marching toward the Holy Land, and Janib bin said them that the sea will part for them so that they can walk all the way. Whenever they are slain as a nation. He is said to be the sea. He claims that their food will never grow, and the leaves and fishes. He marries followers if they want it, and devotes them to. He even had many martyrs among powerful people.

### Shepherds seeking new pastures have invaded Germany

...of the city of Baghdad. It was based on the depiction, who first brought the gold pillars of the Hanbury. He was soon joined by three and millions as well. The crusaders are supposed to be marching toward the Holy Land, and Janib bin said them that the sea will part for them so that they can walk all the way. Whenever they are slain as a nation. He is said to be the sea. He claims that their food will never grow, and the leaves and fishes. He marries followers if they want it, and devotes them to. He even had many martyrs among powerful people.



## Atlas of the Year 1000

We badly need more "wide history" as developed in this remarkable work by John Man. Rather than go linear, Man goes wide with a view of dispersed cultures interacting at one time—in this case in the year 1000. He shows what's happening during this "year" in each region of the planet (say, Tibet, Oceania, South America) and how events then resonate across the globe. The first millennium was the first era when most of the world was settled, and the first time immigration and travel created a robust communication network. Globalism, it turns out, was a medieval event. The picture I got from this book of diagrams was of a world far more sophisticated in its reach and depth than I knew.

—KK

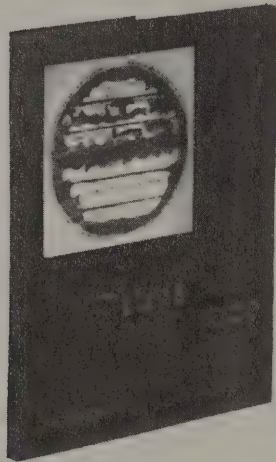

It is often said that the year 1000 has no 'real' importance, that it acquires significance only from its zeroes, from our determination to read significance into birthdays and big numbers. Far from it: the time has a real historical significance, rooted in the way human society developed, from scattered diversity to today's 'one world.'

The significance is this: by pure coincidence, the year 1000, or thereabouts, marked the first time in human history that it was possible to pass an object, or a message, right around the world.

This is very different from history as written in Europe, China or the Islamic world, where the story of the past is in large measure rooted in human character—history as narrative. In the American drama, this element is missing. This section of the *Atlas*, like other sections on nonliterate cultures, necessarily has a wide focus. There are few incidents, few individuals—in all of North America around 1000 there was no native American whose name has survived.

### Atlas of the Year 1000

John Man  
1999, 144 pages  
\$26  
Harvard University Press

#### India: Fleeting Power, Enduring Glory

The Chola dynasty sprang from the rice-rich plain of the River Kaceri, today's Tamil Nadu. They had ruled here as minor chieftains for 800 years when, in the middle of the 9th century, they emerged as heads of a small independent state.



## The Year 1000

### What Life Was Like at the Turn of the First Millennium

A readable chronicle of what ordinary life felt like 1,000 years ago, in England.

—KK

It is a commonplace that slavery made up the basis of life in the classical world, but it is sometimes assumed that slavery came to an end with the fall of Rome. In fact, the Germanic tribes who conquered Rome captured, kept, and traded slaves as energetically as the Romans did—as indeed did the Arab conquerors of the Mediterranean. The purpose of war from the fifth to the tenth centuries was as much to capture bodies as it was to capture land, and the tribes of central Germany enjoyed particular success raiding their Slavic neighbors. If you purchased a bondservant in Europe in the centuries leading up to the year 1000, the chances were that he or she was a "Slav"—hence the word "slave."

Slavery still exists today in a few corners of the world, and from the security of our own freedom, we find the concept degrading and inhuman. But in the year 1000 very few people were free in the sense that we understand the word today. Almost everyone was beholden to someone more powerful than themselves, and the men and women who had surrendered themselves into bondage lived in conditions that were little different to those of any other member of the labouring classes.

There was no spinach. This did not appear in European gardens until spinach seeds were brought back from the Crusades in the twelfth century. Broccoli, cauliflower, runner beans, and brussels sprouts were all developed in later centuries by subsequent generations of horticulturalists. Nor were there any potatoes or tomatoes. Europe had to wait five centuries for those, until the exploration of the Americas, and though the recipe books describe warm possets and herbal infusions, there were none of the still-to-be-imported stimulants—tea, coffee, or chocolate.

## The Year 1000

### What Life Was Like at the Turn of the First Millennium

Robert Lacey and Danny Danziger  
1999, 230 pages  
\$23  
Little, Brown

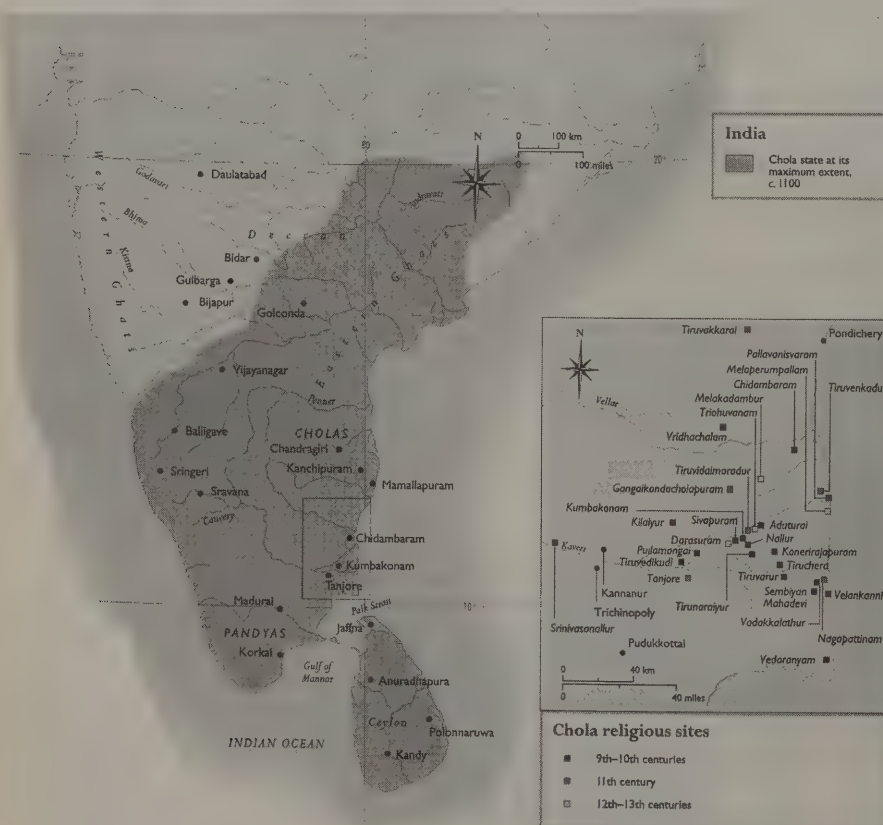
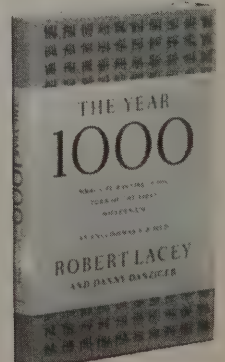



## World War II The Lost Color Archives

It's eerie how the simple addition of color can utterly transform our notions of the past. The restoration of color to World War II takes it from a remote, starkly defined monument into an immediate, vibrant, contemporary experience. It's at once more shocking and more beautiful. Enough experimental color footage (digitally restored) was filmed by US, German, and Japanese photographers to provide this amazing three-hour account of the war from all sides. This is how the participants of Europe and the Pacific saw it. Their words and letters form the narration for this British product. The color picture is so memorable that much of the footage was deemed too "realistic" to be shown at that time. Some of it has never been shown before. Disturbing though it is, this is the version that one wants to remember of the last world war.

(To confuse matters, there is a similarly named video/DVD called World War II in Color, which is also good, but it has less footage (two hours), no letters in narration, and a more US-biased view.)  
—KK

**World War II  
The Lost  
Color Archives**  
VHS, \$29.95  
DVD, \$44.95  
1999, 165 minutes  
From, for example, Amazon

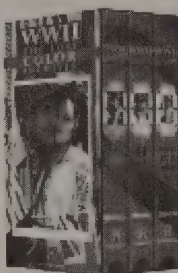

## The Victorian Internet

A quick read that draws the parallels between the early world of telegraphs and the Internet a century later. There are some wickedly perfect fits: hackers, lovers, outlaws, and spies were the first users of the telegraph as they were on the Internet. The first frontiers to be bent, then as now, were language, law, and business practices. And almost every contemporary fear of the Internet is a recapitulation of the fears back then—that gambling, romance, and crime would overwhelm the medium. The telegraph was full of hype—much of which came true. And no one had any idea of what they were doing. These lessons should be oil on water, calming down the excessive worry and enthusiasm for today's telegraph.

—KK

### The Victorian Internet

Tom Standage  
1998, 227 pages  
\$12  
Berkeley  
Publishing  
Group

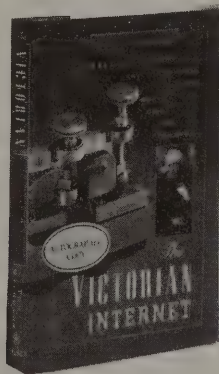

The telegraph was increasingly hailed as nothing less than the instrument of world peace. "It brings the world together. It joins the sundered hemispheres. It unites distant nations, making them feel that they are members of one great family," wrote Cyrus Field's brother Henry. "An ocean cable is not an iron chain, lying cold and dead in the icy depths of the Atlantic. It is a living, fleshy bond between severed portions of the human family, along which pulses of love and tenderness will run backward and forward forever."

Another banquet was held for Morse at Delmonico's in New York in December 1868, where he was toasted for having "annihilated both space and time in the transmission of intelligence. The breadth of the Atlantic, with all its waves, is as nothing."

Running two and later three round-trips each week and carrying her capacity of 300 passengers each way and 200 tons of freight upriver, the *Senator* probably grossed \$40,000 weekly and over \$2 million that year. To convert to 1998 dollars, multiply by 19.23: over \$38 million—for one steamboat!

A miner might pay \$300 for a horse worth only \$6 the month before, ride it to the next camp, and turn it loose because he could more easily scrape up enough gold to buy a new horse than take care of the first one.

Statistics from the district attorney for San Francisco affirm the gracious amenability of sheriffs and judges to timely bribes: for 1,200 murders committed in the city between 1850 and 1853, the official legal system managed to sentence and convict only one defendant.

By 1870, 39 percent of California's population was foreign born.

Owners and speculators in times of bonanza often made millions, concentrating wealth and power to a degree unknown in the 1850s, when California's placer mining had spread the rewards of labor and luck so widely that it seemed almost everyone was well off, or felt confident he would be next week. But in the sixties, and more painfully in the seventies, that confidence faded. Making a living became more urgent than making a fortune. The promise of wealth, of striking it rich, was slipping away from the man with a shovel in his hand. Kid gloves rather than calluses were the new mark of risk taking and fortune hunting.

## Rush to Riches Gold Fever and the Making of California

The world has never seen a boom time like this current one in California since...well...since the last one in California. By all measures the Gold Rush 150 years ago exceeded any superlatives the dot-coms can come up with today. While this witty and visual book was written without the slightest reference to the current digital boom, every page is stuffed with easily transferred insights. Technology running ahead of the law? Middle-class anarchy? Successful businesses created overnight? Deliberate and rampant hype? Profitable existing companies overturned? The original Gold Rush had them all.

The last two chapters, "Astounding Enterprises" and "Victims of Success," just about sum up the economic lessons of the era, but like panning in the hills, almost any random dig into this book will reward the digger.

—KK

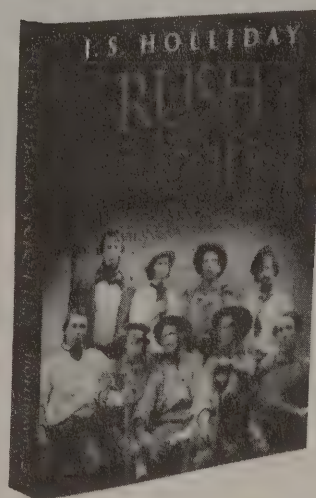

**Rush to Riches**  
**Gold Fever and the Making of California**  
J.S. Holliday  
1999, 355 pages  
\$30  
University of California Press

The intricacies, the precision, the expense evident in this aqueduct of the Miocene Mining Company (near Oroville) suggests profits for sawmills and wages for carpenters—and decimation for nearby forests.





## Sky Atlas 2000.0

This is the definitive atlas of stars for backyard star gazers. Large charts accurately map any star you can see from Earth with amateur optics. There are a lot of them; about 80,000 (visible to magnitude 8.5). Professional atlases list fainter objects, and field guidebooks like Peterson's may be more portable, but the Star Atlas 2000 is now the standard reference star catalog for serious buffs navigating into deep space.

—KK

### Sky Atlas 2000.0

Wil Tirion and Roger W. Sinnott  
1999 (2nd edition), 30 pages (26 charts)  
Deluxe version, spiralbound  
\$50  
Cambridge University Press

[Sky Atlas 2000.0, 2nd edition, is available in a confusingly array of versions: Deluxe (black stars, white sky, color deep-sky objects), spiralbound, \$49.95, or hardcover \$79.95, or in two black-and-white versions: Field (white stars in black sky), or the inverse Desk (black stars in white sky). Both black-and-white versions are available either as loose charts, boxed, \$29.95, or as laminated pages, spiralbound, \$69.95. The consensus among amateur astronomers is that the spiralbound deluxe version of black stars on white sky with color objects is the most useful.]

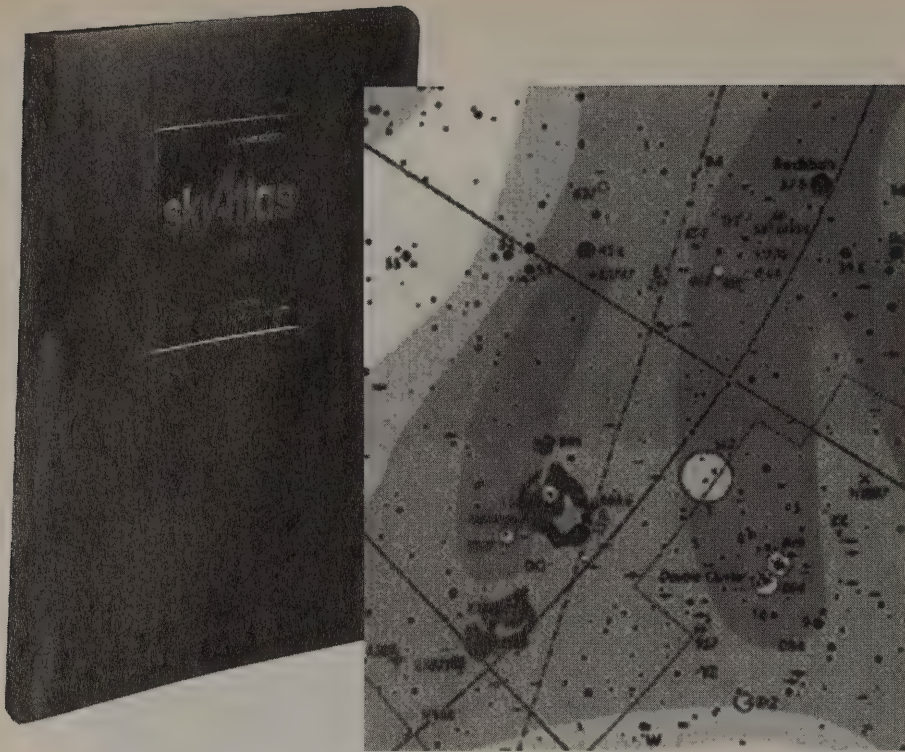

## Magnificent Universe

Oh my God! The universe displayed. Magnitude and majesty beyond belief. Of all the books collecting snapshots of the viewable universe, this one has the best portfolio of heavenly species.

—KK

### Magnificent Universe

Ken Croswell  
1999, 210 pages  
\$60  
Simon & Schuster

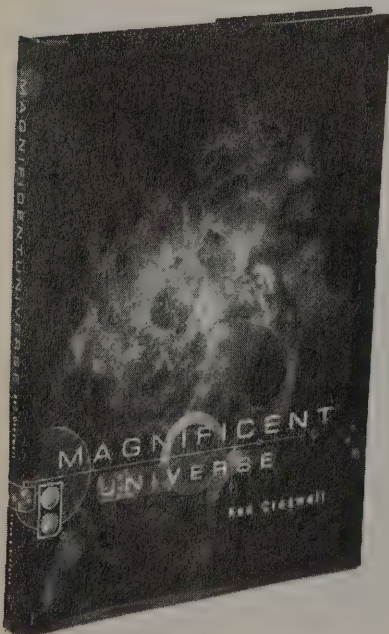

The Sombrero Galaxy, a type Sa Virgo member, sports a large bulge.

The Virgo cluster harbors thousands of other galaxies, too-ellipticals, spirals, and irregulars.





## The Universe Map

*The first modern map of the known universe. Spacey. Trippy. An ingenious design locates our habitat in the very grand order of things.*

—KK

### The Universe Map

2000, 20 x 31 inches

NSG # 602011

\$15

National Geographic Society Maps

800-962-1643



Village of Koh Pannyyi, in Phangnga Bay near Phuket, Thailand. Koh Pannyyi is a fishing village floating on bamboo shoots.

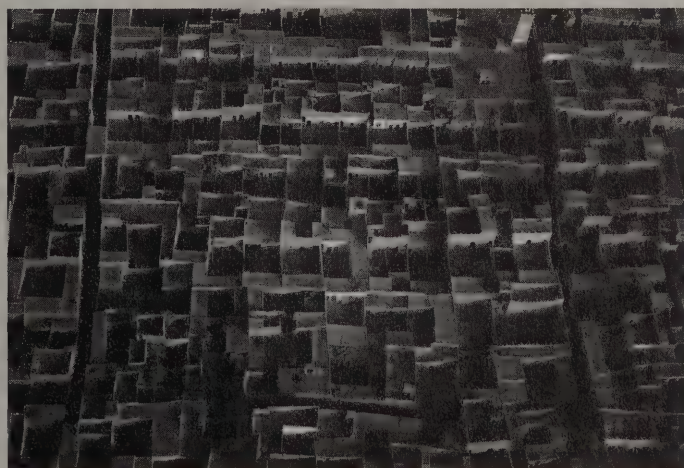

Village in Rheris Valley, Morocco. Fortified villages are frequent along the valley of the Rheris, as they are on most rivers of southern Morocco.

## Earth From Above

*To change your perspective on things, go up and look down. This volume has a portfolio of aerial views similar to the Georg Gester classics, Grand Design and Below from Above, but without those books' lyrical elegance. There's wider variety here, blunter politics (clear-cutting, ugh!), and more of the Earth's bioregions covered.*

—KK

### Earth From Above

Yann Arthus-Bertrand

1999, 423 pages

\$65

Harry N. Abrams

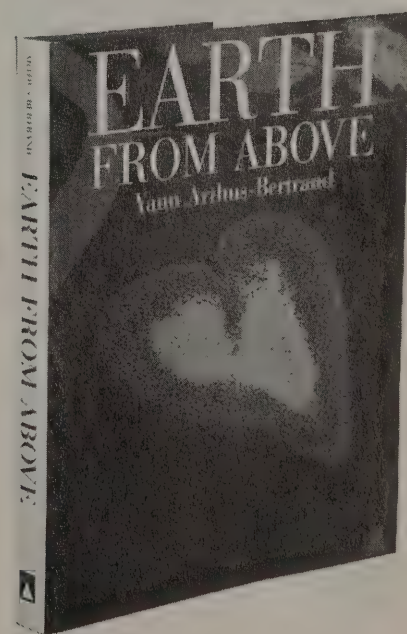



## The Times Atlas of the World

This is the best atlas of the world. Period. It is the most accurate, clearest, most-up-to-date, and most comprehensive atlas ever published. Unlike previous atlases, it locates and names those hundreds of thousands of towns where most of the people of the world live. Take any place you want in any other atlas you want—Afghanistan, Botswana, China—and compare that spot to the stunningly crisp and full maps here. You suddenly realize the other atlas is just waving their arms vaguely. Usually places outside of the US and Europe are reduced in size and left blank. Here, they prosper in splendid microscopic detail. In my travels I've found even large country-specific maps don't have the depth of reality of these pages. I now wince with pain if I have to use another atlas; browsing this one is bliss. It's got all the creeks of the Congo, all the roads of Russia, all the oases in the Gobi. And half this atlas is a divine index of 225,000 place names, with geographical coordinates in degrees and minutes. I'm in heaven! This is the fairest picture of human places on this planet yet.

—KK

## The Times Atlas of the World

1999 (10th Comprehensive Edition), 400 pages  
\$250  
Times Books

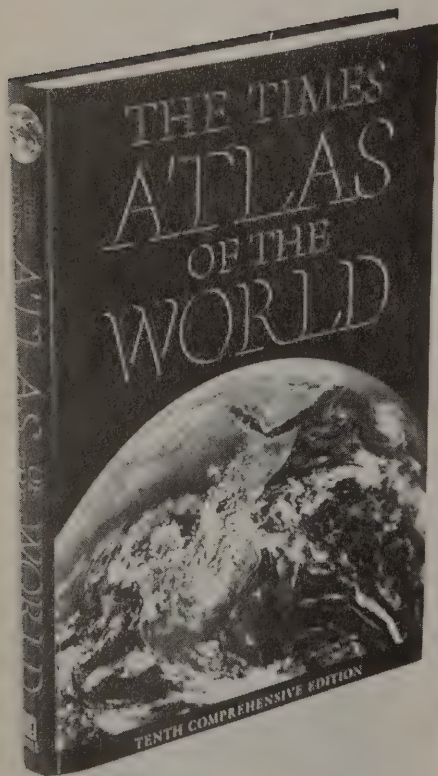

## Ethnologue

The Ethnologue is one of the most satisfying and evocative global snapshots I've ever come across. Compiled by the Summer Institute of Linguistics, a global Bible-translation organization, the Ethnologue is an attempt to inventory and describe all extant (and many dying) languages around the world—in two fat, complete volumes. Open up to the "Language Family Index" and you can test your knowledge of the relationships between ethnic groups in your favorite part of the world. How about the various writing systems for Batak Toba, or the total number of languages in Papua New Guinea, or the population of Swahili speakers in the United States? I often find myself roaming through it, wandering imaginatively across the tangled pathways of evolutionary, political, and economic history that these 7,000 languages represent.

—Jim Mason

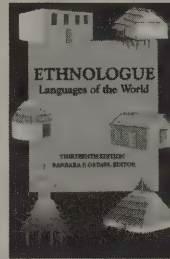

## Ethnologue

Barbara F. Grimes  
1999 (14th Edition)  
Vol I: *Languages of the World*, 858 pages, \$44  
Vol II: *Maps and Indexes*, 727 pages, \$36  
CD-ROM version, including both volumes, \$29.95  
Summer Institute of Linguistics  
7500 W. Camp Wisdom Road  
Dallas, TX 75236  
972/708-7404  
www.sil.org

Much of the material is online in a very searchable format at  
[www.sil.org/ethnologue/](http://www.sil.org/ethnologue/)

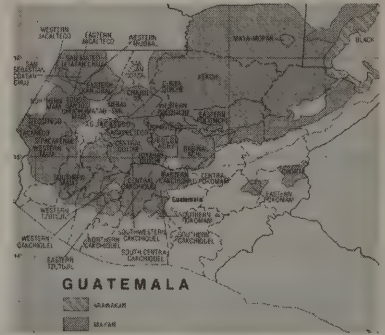

This is the part of the world that is normally left blank. Known as the Empty Quarter, it isn't empty here.

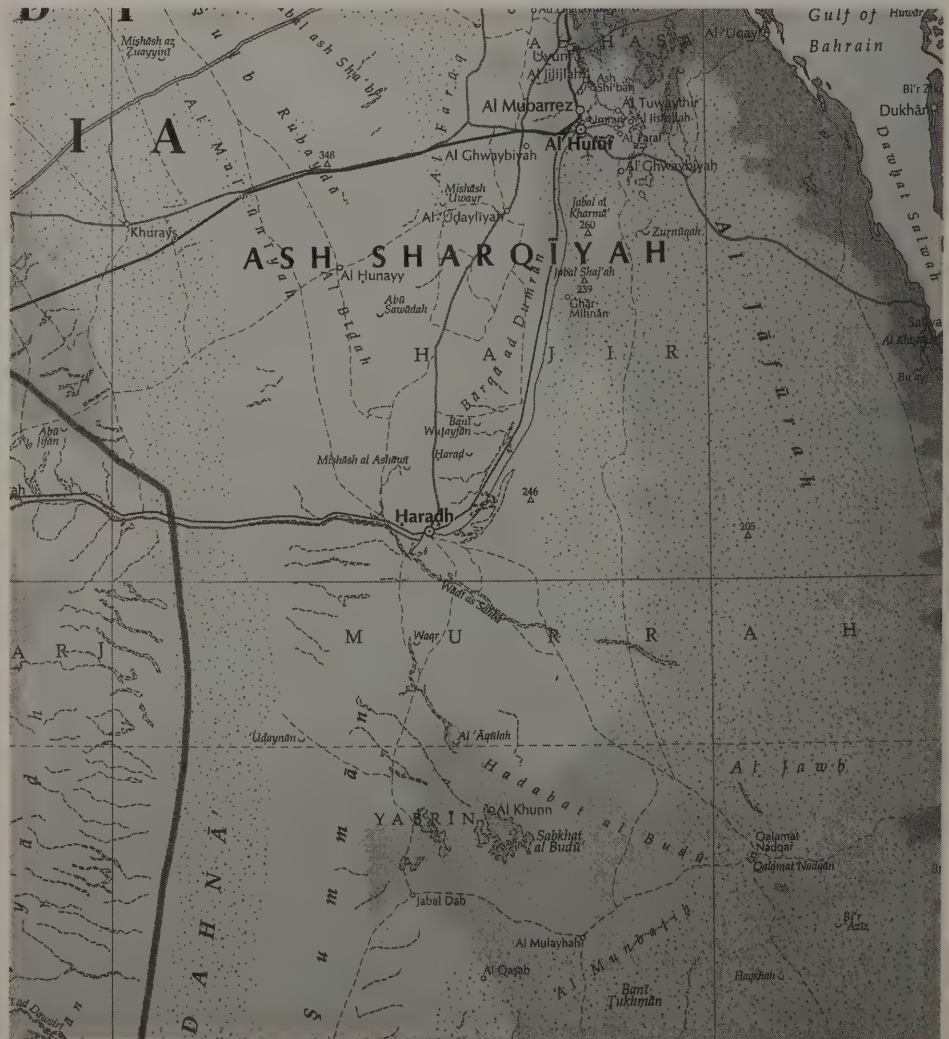



## Baraka

A cinematic poem celebrating the human relation to the eternal. Not a word is spoken, but every person alive in the twenty-four countries this was filmed in would understand it. It's about Us on Earth Now. It's the first truly sacred film I've seen (best viewed in DVD on as large a screen as possible). Next time they send a disc into space to be viewed by aliens, this is the disc they should send.

—KK

### Baraka

Ron Fricke  
1992, 104 minutes  
DVD, \$24.90  
VHS, \$17.99  
Magidson Films  
www.mpimedia.com

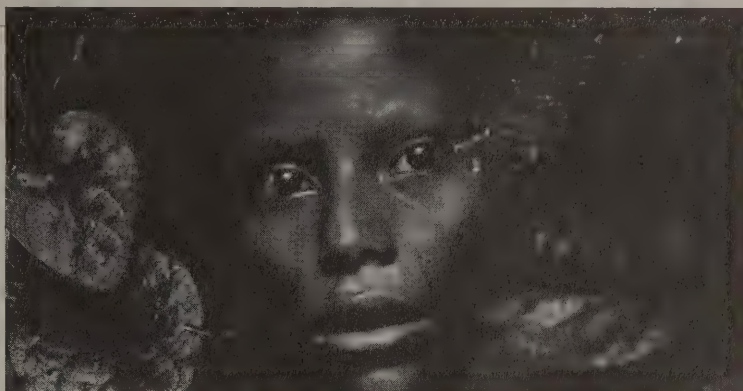

## Mercator's World

A community feeding the urge for visually compressed history—old maps, rare charts, atlases, and globes.

—KK

### Mercator's World

The Magazine of Maps, Exploration, and Discovery

Gary Turley, editor  
\$39.95, 1 year (6 issues)  
Aster Publishing  
845 Willamette Street,  
Eugene, OR 97401  
541/345-3800  
circulation@mercatorsworld.com

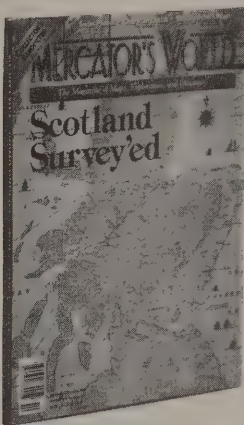

## Breath by Breath

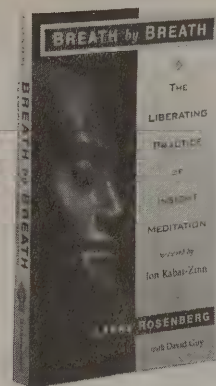

### Breath by Breath

Larry Rosenberg  
1999, 240 pages  
\$14.95  
Shambhala  
Publications

On holiday recently, I was confronted with a situation that caused me discouragement and humiliation. Using the lessons of this book, I breathed while drawing my attention to my breath, observed the emotions arise, and without attaching to them, allowed them to pass. I was able to get back to enjoying my holiday. The breathing and observing and letting it pass—the essence of meditation on the breath as set forth by Buddha 2500 years ago—enabled me to break the typical habit of getting attached to a negative emotion and replaying it over and over. Another side effect of practicing this meditation technique—during the day, I notice more often when my mind is living in the past or future, and I can remember to return to the present. That's all Buddhist enlightenment is, I think—remembering to live in the present, and refrain from getting attached to transitory phenomena like our thoughts, emotions, and bodies. This technique works, and this book is the best explanation I've found about why and how it works.

—Howard Rheingold

But it is also true that much of what the sutra describes will turn up naturally if you just sit and follow the breathing, if you persist in that practice over the course of days and months and years. It is natural for your attention to deepen until it includes the whole body, and for that process gradually to calm the body. Once your attention is in the body, you begin to notice feelings and your mental reactions to them, which lead you into the mind as a vast realm to explore. Finally, if you're paying attention, you can't help noticing that all the phenomena you're observing arise and pass away, that they are impermanent and lack an essential core.

Map Cataloguer Wanted.

Paying \$40,000–\$100,000 a year depending on experience.

\$100,000,000 collection needs to be catalogued, organized and made available for sale.

Profit sharing, joint ownership, housing available.

Adarnemyc@hotmail.com

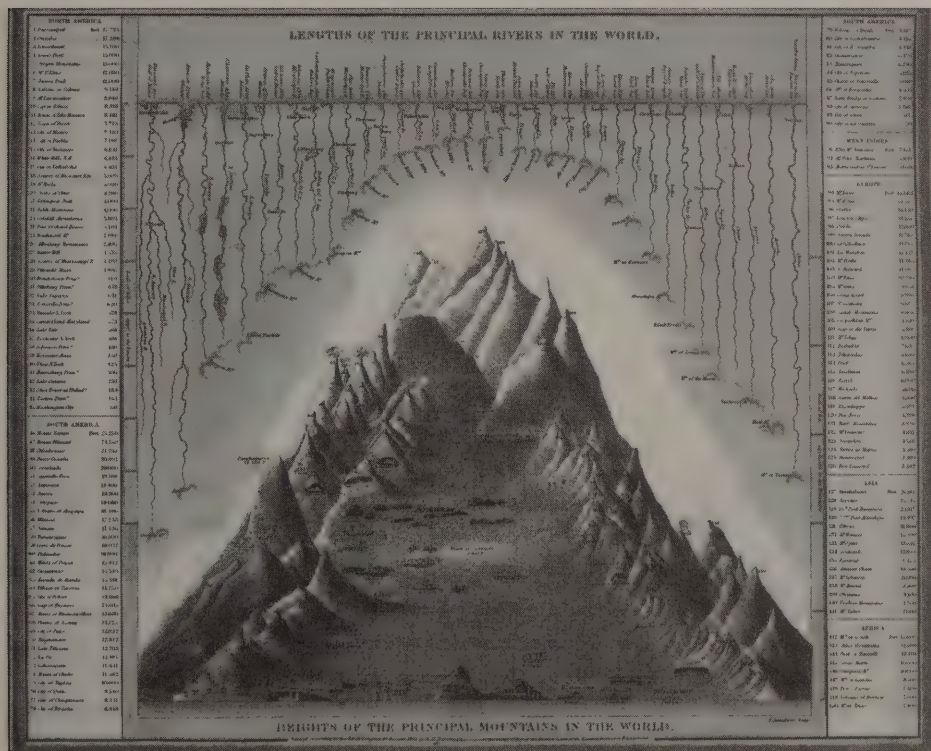

Plate 72 from Samuel Augustus Mitchell's *New Universal Atlas*, published in 1846, illustrating the heights of mountains and the lengths of rivers.



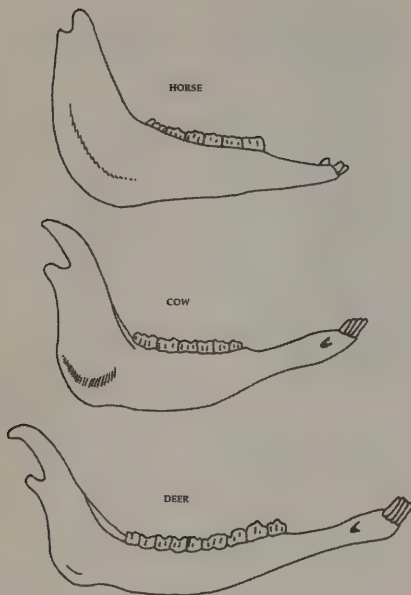

Figure 2.14.  
The long flat mandible shape typical of ruminant and perissodactyl herbivores.

## Skulls and Bones

### A Guide to the Skeletal Structures and Behavior of North American Mammals

An animal becomes hard to identify when time whisks away its spirit, and the elements strip away its fur and meat, so that all that is left is bones. It would be wonderful to have a field guide to bones, but this isn't it. Until one is written, you can try thumbing through this book—which considers only mammals of North America, and that spottily—to get a sense of the distinctions between the bones of species. This is more like paleontology of the recently deceased.

—KK

## Skulls and Bones

### A Guide to the Skeletal Structures and Behavior of North American Mammals

Glenn Searfoss  
1995, 277 pages  
\$19.95  
Stackpole Books

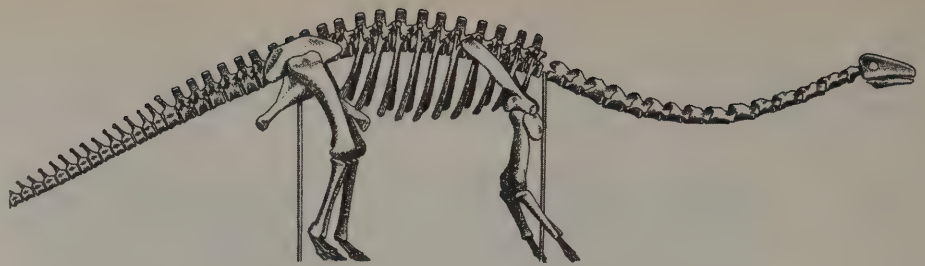
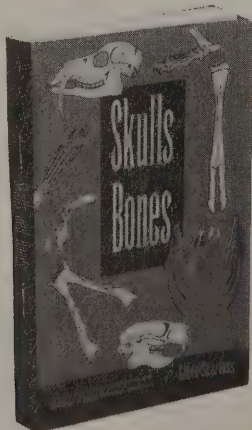

## Make Your Own Dinosaur Out of Chicken Bones

Yep. Totally cool. Birds are distant descendents of dinosaurs, so you should be able to make a miniature dinosaur skeleton using three dead chickens. Right? This book tells how to. How to nip and tuck the chicken bones to modify them into the needed dino bones, and then how to assemble the skeletal frame. In the process you'll learn amazing amounts of dino anatomy, and a new appreciation of chickens. We made it a family project; took several months.

—KK

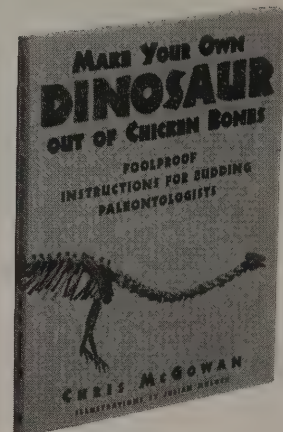

## Make Your Own Dinosaur Out of Chicken Bones

### Foolproof Instructions for Budding

#### Paleontologists

Chris McGowan  
1997, 144 pages  
\$13  
HarperCollins

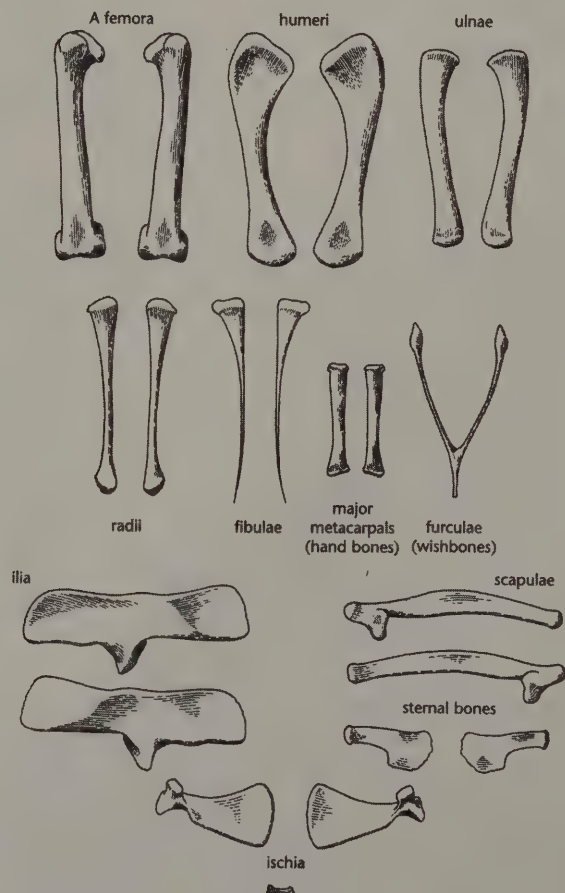

A complete set of required bones from a single chicken (see page 28 also).



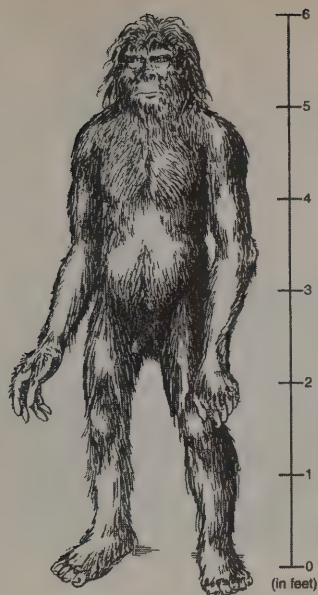

## The Field Guide to Bigfoot, Yeti, and Other Mystery Primates Worldwide

The thousands of worldwide sightings of unclassified bipedal primates, including the Yeti, may be confusing because these sightings entail more than one species. This field guide attempts to sort out the different creatures, coming up with a classification of eight possible mystery primates. But this book makes no real attempt to persuade skeptics of the existence of any of them. It's sort of speculative taxonomy, but I think it is one of the most useful texts in the ongoing controversy over Bigfoot—which, I will admit, I thoroughly believe exists.

—KK

### The Field Guide to Bigfoot, Yeti, and Other Mystery Primates Worldwide

Loren Coleman and Patrick Huyghe  
1999, 207 pages  
\$12.50  
Avon Books

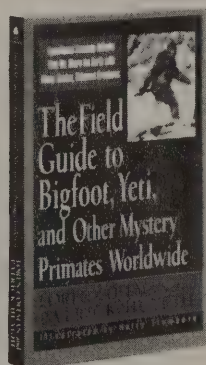

Two decades after Sanderson, the British anthropologist Myra Shackley surveyed the situation in her book *Still Living?* and divided the reports of hairy hominids worldwide into just three types: (1) the chuchunaa from Siberia, which she theorized were now extinct or assimilated by humans; (2) the Sasquatch or Yeti (she used the terms interchangeably), which are present in North America, the Himalayas, the Pamirs, Siberia, and China, and which she linked to Gigantopithecus; and (3) the almas, which range from the Caucasus Mountains eastward to Mongolia, and which Shackley believes are probably Neandertals.

## Trailmaster Trail Monitor

I live adjacent to a national recreation area where we enjoy a year-round parade of wildlife past our house. For years now I've been looking for a little gizmo that would take advantage of a point-and-shoot camera (with auto exposure and focus) to capture pictures of wildlife triggered by their own movement. The gadget I fantasized about would link an ordinary household motion detector to a camera, which could then be set up along a trail on the hills behind our house. To my great delight, precisely this gizmo can be had from the good folks at Trailmaster.

Trailmaster makes several models of infrared wildlife monitors. These battery-operated devices detect movements that can easily be used to trigger a camera. Indeed, Trailmaster sells a kit that includes a specially modified weatherproof auto focus/exposure Yashica camera, a 25-foot connecting cable, plus hardware to mount them in the wild, for \$290.

The clock in the monitor can be set to trigger the camera only at night, or only in day, or at any hours of your choosing. The motion detection system can also be tweaked to detect, say, only large animals, or only fast-moving animals, so that when correctly placed it can be used to selectively distinguish certain animals.

Many people purchase the monitor alone as a counter. Biologists taking censuses of animal populations or hunters tracking game are typical users. But the real joy is in photography.

Detector-enabled cameras are becoming a key tool in conservation work. Because they are unobtrusive, eternally patient, and immune to sleep or bad weather, they see things observers keep missing.

Trailmaster monitors are enabling field biologists in Africa, Asia, and South America to detect species of animals in areas no one knew they inhabited. Once an animal's existence is proven by film, it becomes easier to find other evidence of its presence.

The technology works just as wonderfully in backyards or local wildernesses. I purchased a Trailmaster passive monitor camera kit (\$180), which is geared to sensing all wildlife in a wide field of vision, to try to catalog all the animals active on the trails in the hills behind our house. In addition to the fox, coyote, and bobcat I knew about, I suspected that there was mountain lion (I live 12 miles from downtown San Francisco!). I haven't captured any cougars yet, but the camera is catching all kinds of other critters, especially the nocturnal ones we seldom see. (It takes some experience to aim the set-up effectively).

The coolest thing is the way getting film back from the processor is like Christmas every time. You open up the envelope with no idea what you've got. It certainly has broadened my view of the neighborhood.

—KK

### Trailmaster Trail Monitor

TM550 Passive Infrared Trail Monitor  
\$180  
TM35-1 Camera Kit  
\$290  
Trailmaster  
800/544-5415  
www.trailmaster.com

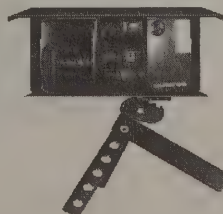

The TM550 must be mounted on a tree or post that does not move. The sensor is a heat-and-motion sensor and is dependent on being stationary to work properly. The camera can be located up to 25 feet away from the TM550.



"For more than 20 years I have been studying tigers at Royal Chitwan National Park in Nepal. Recently I purchased one of your Trail Master TM 1500 units and the camera, in order to take identification photos of tigers. The second night I put it out by a road and got an excellent photo of a tigress. Then I decided to put it up by a trail that runs along the crest of a ridge. I set it up about two yards off the path. At 0902 one morning a male tiger walked through the beam and activated the unit. The almost inaudible 'click' made by the camera got his attention. He attacked, knocking over the tripod. Seizing the camera in his mouth he carried it 80 yards down the trail before dropping it. One of the tiger's canines penetrated the body of the camera, leaving a sizable hole just at the spot where the film winds on. I dismissed the possibility that the photo would come out, but against all odds, it did. I enclose a copy. Amazingly, the camera still works...."



The 4" vertical beam height spreads one (1) foot for every ten (10) feet you move away from the TM550.

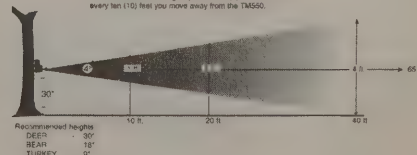



## Garmin GPS

Now that GPS readers have maps, and now that the distortion has been expunged from the satellite signals, yielding ten-yard accuracy, portable Global Positioning devices have become essential. There's a featureless dirt road leading off Highway 50 to one of the nicest wild hot springs in Nevada. Since marking its waypoint years ago, I never miss the turnoff even in the middle of the dark desert night. Computer downloadable detailed feature maps and topo maps have raised GPS usefulness yet another level, even showing old trails left off current paper maps. I constantly use and almost revere the pocket-size Garmin III Plus.

Recently I had the chance to drive a friend's car equipped with the Garmin StreetGuide (\$680), sporting a largish color display and abundant detail. I expect I'll get one.

—SB

### Garmin III Plus Personal Navigator

\$574 list, \$350 street

From, for example, Amazon  
[www.amazon.com](http://www.amazon.com)



## Thommen Altimeter

The universally acknowledged best analog altimeter is the Thommen Classic. Accurate to 10 feet elevation, it's intuitively easy to set and read, and it has none of the tiresome trickiness of digital altimeters. Altitude is work; altitude is location. It's good to know exactly where you are.

—SB

### Thommen TX-20 Altimeter

Good up to 27,000 ft.  
\$399.00

### Thommen TX

Good up to 15,000 ft.  
\$279.00

From, for example, REI  
[www.rei.com](http://www.rei.com), 800/426-4840

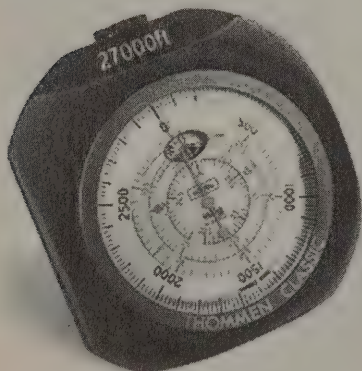

## Brunton Classic Compass

Electronic compasses are too jittery. Most cheap compasses don't let you adjust for declination between magnetic and true north, so in central California they show a north 16 degrees off of true. For \$10 you can get a well-designed, minimalist but big enough to read easily, intuitively readable, Brunton compass with friction-twist declination adjustment. I bought three, so they're scattered around pack, shoulder bag, and jacket. I like to know where north is.

—SB

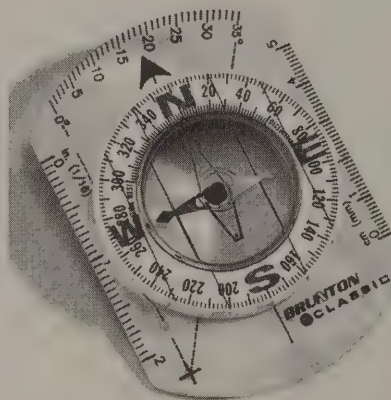

### Brunton Classic 9020G Compass

\$10  
From, for example, REI

## Kestrel 3000 Pocket Weather Meter

A marvel of compact engineering, this brilliant little device now accompanies me wherever I travel, not just in the wild any more. Two buttons. One is on/off. The other cycles the readout through current wind speed, maximum wind speed, average wind speed, temperature, wind chill, relative humidity, heat index, and dew point. It is shockingly sensitive. Once when I was hiking up into a fog layer, I tracked—while I was walking—the decrease in temperature and rise in humidity, with indicated dew point ever closer to the ambient temperature. As I entered the fog, humidity reached 100 percent and the ambient temperature and dew point temperatures were identical. Precisely! Pocket-small, the Kestrel's slide-on case can't be lost because it's on the lanyard.

—SB

### Kestrel 3000 Pocket Weather Meter

\$160  
From, for example,  
[www.precisionreloading.com](http://www.precisionreloading.com), 800/684-5680





## Danner Boots

*Much as I love Vasque boots, they're not what I use on trails. Three years of slogging up a local mountain before dawn twice a week with a heavy pack convinced me that lightweight trail running shoes are the footwear of choice for trail use. (I came to prefer Nike's Air Terra series, the best being the now-discontinued Ailbris.)*

*But the joy is going off-trail, and for that, calf-high hunters' boots are the best, though largely eschewed by backpacker aesthetic. High boots with Goretex linings let you wade through significant water and bash through thick brush with aplomb. Ankle anxiety disappears. The premium brand is Danner. For summer I like the Whitney, which achieves light weight with Cordura everywhere except heel and toe. My winter boot is the SUV of boots, the Danner Fort Lewis, 11 inches high, all leather, with Thinsulate insulation. It's a go-anywhere boot, not as heavy as it looks. Find a local hunters' supply store to get the best fit, or use a hunters' catalog like Cabela's or Danner's direct.*

—SB



69110 Fort Lewis, Insulated 200 gram



52000 Whitney 8" Uninsulated

## Danner Boots

52000 Whitney 8" Uninsulated  
\$220  
69110 Fort Lewis Insulated 200 Gram  
\$250

Danner Shoe Mfg. Co.  
800/345-0430  
[www.danner.com](http://www.danner.com)  
or  
Cabela's  
800/237-4444  
[www.cabelas.com](http://www.cabelas.com)

## Skillers Duckweave Pants

*"These pants are made for working, and that's just what they'll do," it says in the catalog, and that is no shit. These pants are vastly sturdier, longer-lasting, more comfortable and beautiful than jeans. They have pockets below the knee that accommodate their custom-fitted light-weight kneeling pads. Those pads alone are worth the \$60 price. I never realized how often around the house, tractor, and woods, I found myself holding my body at an uncomfortable, back-stressing angle until I had these pants that made kneeling easy and restful. They have pull-out pouches for nails or screws that are reverse slashed so you can get into them with either hand. In a marvelous example of intelligent design, these hang outside—unless, if they're not full, you want to tuck them inside the regular front pockets. An array of other pockets can hold everything from a cell phone to a wrench. They're the ultimate cargo pants.*

*A word of caution: I had to send my first pair back because I was fantasizing about my waist size, using the size from my last pair of jeans. These pants are brutally honest, and they want to fit up around your belly button, which is a problem if you no longer have as much of a waist as you did when you were 23, but like to think you do. So don't suck it in. Stand like you will be when you're holding a chain saw and when in doubt, buy one size larger. You can always burn the tag.*

*The final kick is that these pants blow away the straights, should you choose to wear them in on casual Friday. When I got my first pair as a present, my daughter, The Coolest Woman in the Northern Piedmont, said enviously, "Daddy, you're having a very butch Christmas." Women in the office cooed and agreed.*

*For the full package, you want to add White's Boots (the ones you want are the Logger - Smoke Jumper model), a Leatherman in a small leather carrying cases, a Mini Maglite flashlight (it's amazing how often you'll use it) in a black web carrier, and a belt custom-made by your local leather crafter to properly display your Cold War victory trophy of a Red Army belt buckle.*

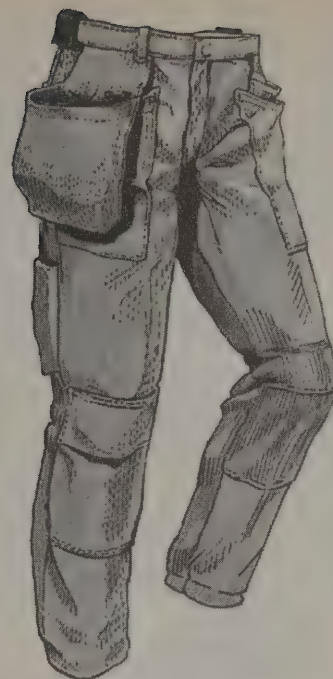

*For this and other extraordinarily desirable gear, go to my favorite wish book, the Duluth Trading Co. catalog.*

—Joel Garreau

## Skillers Duckweave Pants

\$59  
Duluth Trading Co  
8300 Highland Drive  
Wausau, WI 54401  
[www.duluthtrading.com](http://www.duluthtrading.com), 800/505-8888

## Mephisto Shoes

*French and expensive, Mephistos are what walking sneakers should be: good looking, hard wearing, and very comfortable. I wear the basic black model all the time, so much that I now take advantage of Mephisto's offer to resole their shoes indefinitely. Since the shoes are leather, they adapt to your peculiar foot (such as my bunions), and they're robust enough to carry on for many years with occasionally refreshed soles. I own two pair, so one is working while the other is in the shop.*

—SB



## Mephisto Shoes

About \$200, from places like  
<http://www.mephistogreatlakes.com/>  
or  
<http://www.handshoe.com/>

## Nike Air Mocs

*The clog's promise of being an all-terrain slipper is a failed promise. Clogs are heavy, clunky, and fall off under duress. Air Mocs do all the things clogs are supposed to do, and they are the most comfortable shoes I've ever worn. Nike describes them as light hiking shoes, while Cabela's catalog positions them as camp moccasins. I've used them happily in both roles, and as long-distance driving shoes and for office wear. I bought two pair out of fear that Nike would discontinue them. They have no laces, just a pinch-clamp ankle string. Their cushioning layer makes them warm in a chilly camp, but they don't sweat in warm weather. The tread is light but rugged, the Nike swoosh relatively hidden, the look understated. Foot luxury.*

—SB

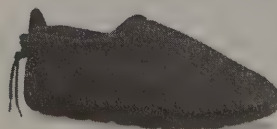

## Nike Air Moc

Nike style#  
175035, \$65  
800-806-6453;  
[www.nike.com](http://www.nike.com)



## Ridge Rest 3/4 Sleeping Pad

For me, one of the pleasures of hiking or trail running is the ability to stop anywhere anytime and read a book or take a nap. With a light pad strapped to my daypack (I like the small Marmot Talus), that's always an option. I can recline on rocky ground, sit on wet moss, and generally treat the wild like a living room. The torso-length Ridge Rest rolls compactly and is plenty soft and warm enough to serve as all-night pad with my sleeping bag.

—SB

## Therm-a-Rest Ridge Rest 3/4 Sleeping Pad

\$13  
From, for example,  
REI  
www.rei.com, 800/426-4840

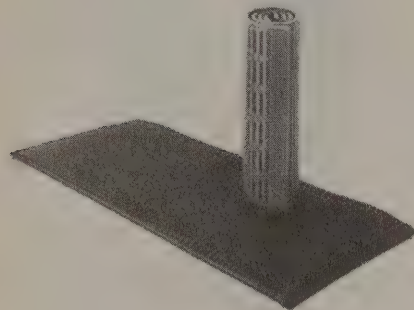

## Tilley Hat

Often copied, never quite equaled, the Tilley Hat is the most all-purpose chapeau I know. Its broad brim keeps the sun or light rain off, the bit of foam in the flat crown pads the skull against light whacks and keeps the hat floating in water, and the double strap defeats all wind. (Use just the rear strap behind your head to hold the hat in all but strong winds; the front strap under the chin is effective but dorky looking.) The Canadian behind the Tilley line has generated a humorous but effective fetishism around his durable hats. With one or both side brims snapped up to the crown you get a rakish look which also stiffens the front brim against wind. The Tilley packs well and does last for many years; however, a lot of hot weather use will stain it incurably with sweat. You may not mind.

—SB

## Tilley Hat

Tilley Endurables Inc.  
\$50.00  
www.tilley.com  
800/363-8737

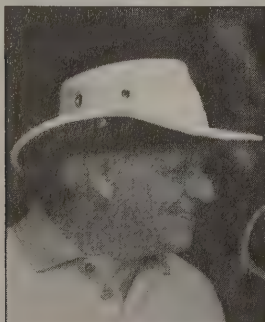

## CamelBak Hydration Systems

The closest thing to the Still Suits worn by the Fremen desert people in Frank Herbert's Dune world, set 10,000 years in the future. You hydrate more often with these because you don't have to reach for anything; the containers can carry up to about two liters. Also they don't bang around on the outside of your pack; the new backpacks often build in pouches to accommodate them. They make insulated ones that don't freeze, which I use for snowboarding.

—Alexander Rose

## CamelBak Classic

\$40  
CamelBak Products, Inc.  
1310 Redwood Way,  
Suite 200,  
Petaluma, CA 94954  
800/767-8725,  
707-792-9700  
www.camelbak.com

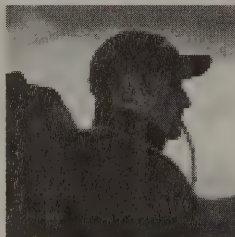

## Princeton Tec Matrix LED Headlamp

The new ultrabright LED-based lamps, like the ones in the Princeton Matrix headlamp, are quite amazing. While the light doesn't reach as far as an incandescent, it is a cool, high-contrast light that doesn't glare when you are reading in your tent or working on something close, and it doesn't have the hotspot incandescents do. (The Matrix also comes with an incandescent bulb if you do ever need the range.) The LED's main virtue: the light lasts for about forty hours on a set of two AA batteries!

—Alexander Rose



## Princeton Tec Matrix LED Headlamp

\$50 list, \$40 street  
From, for example, REI

## Otterbox

Electronics and water don't mix well. Keeping digital gear dry around water is a tricky job made perfect by an Otterbox. Bright yellow, tough as concrete, lightweight, watertight as a submarine, and padded inside, an Otterbox will keep cameras, cell phones, Palms, navigation equipment, or wallets safe and dry through rapids, splashes, or 100 feet of water. They are indestructible.

—KK

## Otterbox

Different sizes  
9000 series,  
3 x 3.75 x 7.5 inches  
\$20  
Otter Products  
970/493-8446  
www.otterbox.com

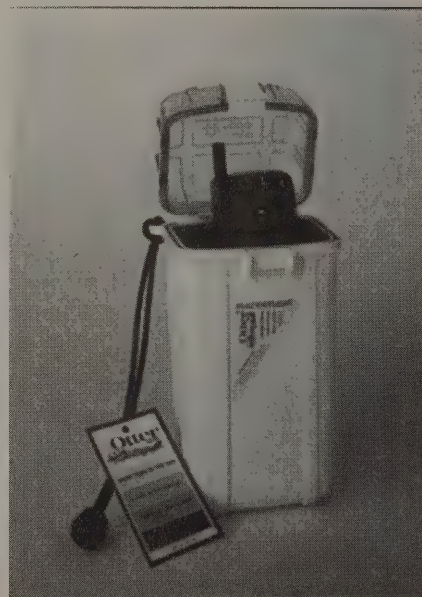



## SEAL Pup Knife

A few years back the SEALs put on a contest for a new knife for military field use. It had to relish salt water, vile chemicals, vile weather, severe use, and non-finesse tasks such as prying open ammunition crates. The winner was a big, tough knife manufactured by SOG Knives. It's too big for civilian use—heavy and halfway to a hatchet. So SOG made a version just as tough but in handier size—9 inches long. It's nice to have a working knife that is all tool and no worries.

—SB

## SOG Seal Pup Sheath 9" Knife

\$70 at  
[www.actiongear.com](http://www.actiongear.com)  
800/338-4327



## Boye Knives

I carry a sheath knife everywhere except on airplanes. People assume a violent or at least self-defense message from the knife, but it has nothing to do with that whatever. For opening packages and envelopes, for stroll-by gardening, for food management I want a sharp edge in my hand instantly, stowable instantly (hence a pouch sheath instead of clip-down sheath).

It's hard to learn what are the best knives from the knife-fetish magazines because they've agreed never to criticize any knife, and gaudy crap gets lauded along with the actual good stuff. After a few years of sifting I settled on knives made by David Boye and his son, mainly because of the steel. Forged in the shape of the knife, it has a "dendritic" structure that gives a micro-saw edge that cuts very aggressively. The blade takes an edge easily and holds it well. Boye has some innovative all-metal designs that I don't like as well as those with traditional handles. Custom models are available with fancy materials in the grip and etched blades, and there are some good kitchen knives in the line.

—SB

## Sharpmaker

A knife without an edge is worthless, and most knives you find in pockets, sheaths, and kitchens are dull. Every edge you have, including an ax, should be able dry shave hair off your forearm, should slice loose-held newsprint without catching.

The most effective sharpener I know is also the easiest to use—just carve straight down on the V of slender stones, a stroke on one side, a stroke on the other. The stones are triangular, so you can use either the flat side or the angle (which permits sharpening serrated blades such as bread knives). Spyderco has had the leading product for 20 years and now has a new improved "Sharpmaker" that looks pretty good. —SB

### Spyderco Sharpmaker

\$45 from, for example,  
[www.knifecenter.com](http://www.knifecenter.com)  
800/338-6799

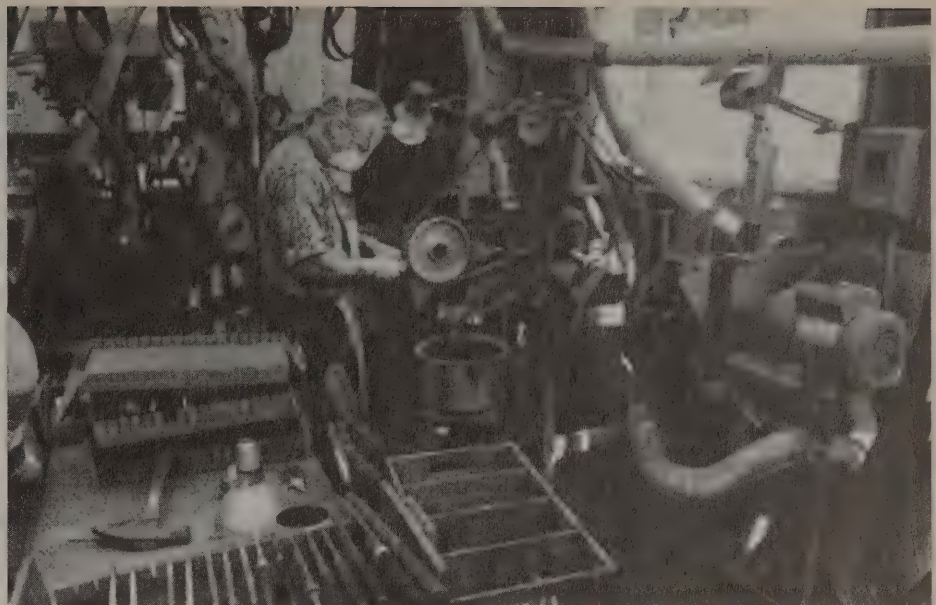
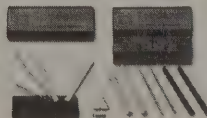

## Boye Knives

The fancy Boye knives come from a gallery in California. 800-557-1525,  
[www.boyeknivesgallery.com](http://www.boyeknivesgallery.com)

A regular all-metal line can be found at places like  
[www.discountknives.com/Boye/Boye.htm](http://www.discountknives.com/Boye/Boye.htm)



From the Web site:

"In 1980, Boye began experimenting with the technique of investment casting for making knife blades. He discovered that casting produces a dendritic (fern-like) network of carbide crystal throughout the steel, and that dendritic steel blades hold an edge from 3 to 10 times longer than other steels commonly used for cutlery. His work is considered to be a revolutionary breakthrough in modern knifemaking."

David Boye demonstrates the edge-holding power of dendritic steel by cutting a one-inch hemp rope more than 3,000 times without resharpening.



## Swiss Army Champ Knife

The Champ is the top-of-the line, everything-included Swiss Army Knife. Made by Victorinox (never Wenger), it includes such niceties as pliers, a tiny screwdriver for glasses (ingeniously screwed into the corkscrew), a tempered pin (crucial for sliver removal, along with the tweezers and magnifying glass), and a ballpoint pen, plus the usual scissors, toothpick, wood saw, awl, etc. It's a bit dense and heavy for pocket wear, so I have it in a pouch on my belt at all times. I use some of its tools all of the time and all of its tools some of the time. Oh, the stories it could tell of situations saved. I'm perpetually amazed that everyone doesn't have one.

—SB

## Swiss Army Champ Knife

\$60.00  
From, for example, REI  
[www.rei.com](http://www.rei.com), 800/426-4840  
[www.4bestblades.com/champ](http://www.4bestblades.com/champ)







Extroverts have more fun. If you see four cute men on a bench, ask them to scoot over.



One carry-on-size bag?? Here's exactly what I traveled with for two months (photo taken in a Copenhagen hotel room).

## Rick Steves' Europe Through the Back Door

An award in heaven should be given to those authors who update their good books every year until they are great books. Rick Steves's guidebook on intelligent travel in Europe has been around decades, but it gets better with each yearly edition. That's because for the past twenty years Steves has spent several months each year exploring new and reexploring odd corners of the continent. From this wealth of experiential he delivers not only the best guide to Europe, but the best general guide to smart traveling anywhere. I spent a decade full-time traveling myself, and these days I go to Europe once a month; this book has directed me to many specific towns or regions that retain distinctive cultures, places which would otherwise have taken me years of visits to find. Among the techniques Steves offers is a sort of laser traveling (head directly from the airport to the quintessential regions, skip the rest) which only works because he hard-earned tips on cheap travel, on getting comfortable with a different way of doing things, and, bless his soul, he updates the darn thing every year with the latest prices. I consume travel books by the barrelful, including *Lonely Planets*, *Rough Guides*, and so on; this is the one to study, the one you want to reread. It's not about London and Paris; it is not a guidebook. It's about how to make jokes in beginners' Italian, or attend a wedding on a Greek island. With Steves's guidance you can finally do that inexpensive grand tour of Europe you've always meant to do, or, better, bestow a roundtrip ticket and this book to a recent graduate and it'll be as good an education as they've had.

—KK

### Rick Steves' Europe Through the Backdoor 2000

Rick Steves  
1999, 483 pages  
\$25  
Avalon Travel

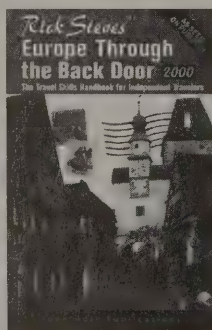

In many ways, spending more money only builds a thicker wall between you and what you came to see. Europe is a cultural carnival, and time after time, you'll find that its best acts are free and the best seats are the cheap ones.

Travel is addicting. It can make you a happier American, as well as a citizen of the world. Our Earth is home to nearly 6 billion equally important people. It's humbling to travel and find that people don't envy Americans. Europeans like us, but with all due respect, they wouldn't trade passports.

**The Big Sleep:** Arrive 30 minutes before your train leaves. Walk most of the length of the train but not to the last car. Choose a car that is going where you want to go, and find an empty compartment. Pull two seats out to make a bed, close the curtains, turn out the lights, and pretend you are sound asleep. It's amazing. At 21:00, everyone on that train is snoring away! The first 30 people to get on that car have room to sleep. Number 31 will go into any car with the lights on and people sitting up. The most convincing "sleepers" will be the last to be "woken up." (The real champs put a hand down their pants and smile peacefully.)

#### Museum Strategies

**Eavesdrop.** If you are especially interested in one piece of art, spend half an hour studying it and listening to each passing tour guide tell his or her story about David or the Mona Lisa or whatever. They each do their own research and come up with different information to share. Much of it is true. There's nothing wrong with this sort of tour freeloading. Just don't stand in the front and ask a lot of questions.

For \$20, you can rent a couchette (bunk bed) on your overnight train. Top bunks give you a bit more room and safety — but BYOB.

#### Tips on Creative Communication

Be melodramatic. Exaggerate the local accent. In France, communicate more effectively (and have more fun) by sounding like Maurice Chevalier or Inspector Clouseau. The locals won't be insulted; they'll be impressed. Use whatever French you know. But even English, spoken with a sexy French accent, makes more sense to the French ear. In Italy, be melodramatic, exuberant, and wave those hands. Go ahead, try it: *Mama mia!* No. Do it again. *MAMA MIA!* You've got to be uninhibited. Self-consciousness kills communication.

#### Desperate Telephone Communication

Let me illustrate with a hypothetical telephone conversation. I'm calling a hotel in Barcelona from a phone booth in the train station. I just arrived, read my guidebook's list of budget accommodations, and I like Pedro's Hotel. Here's what happens:

Pedro answers, "Hotel Pedro, grabd-aboodogalaysk."

I ask, "Hotel Pedro?" (Question marks are created melodically.)

He affirms, already a bit impatient, "Si, Hotel Pedro."

I ask, "*Habla Eng-leesh?*"

He says, "No, dees ess Ehspain."

(Actually, he probably would speak a little English or would say "moment" and get someone who did. But we'll make this particularly challenging. Not only does he not speak English — he doesn't want to... for patriotic reasons.

Remembering not to overcommunicate, you don't need to tell him you're a tourist looking for a bed. Who else calls a hotel speaking in a foreign language? Also, you can assume he's got a room available. If he's full, he's very busy and he'd say "complete" or "no hotel" and hang up. If he's still talking to you, he wants your business. Now you must communicate just a few things, like how many beds you need and who you are.

I say, "OK." (OK is international for, "Roger, prepare for the next transmission.") "Two people" — he doesn't understand. I get fancy, "*Dos people*" — he still doesn't get it. Internationalize, "*Dos pehr-son*" — no comprende. "*Dos hombre*" — nope. Digging deep into my bag of international linguistic tricks, I say, "*Dos Yankees.*"

"OK!" He understands, you want beds for two Americans. He says, "Si," and I say, "Very good" or "*Muy bueno.*"

Now I need to tell him who I am. I say, "My name Ricardo (Ree-KAR-do)." In Italy I say, "My name Luigi." Your name really doesn't matter; you're communicating just a password so you can identify yourself when you walk through the door. Say anything to be understood.

He says, "OK."

You repeat slowly, "Hotel, *dos* Yankees, Ricardo, coming *pronto*, OK?"

He says, "OK."

You say, "*Gracias, ciao!*"

Twenty minutes later you walk up to the reception desk, and Pedro greets you with a robust, "Eh, Ricardo!"



## Leica Trinovid Binoculars

I wound up being disappointed with stabilizing binoculars for most uses. They are wonderful for reading license plates in the next county and resolving the moons of Jupiter, but for general viewing I find them heavy and fiddly. The clearest binoculars that are also glasses-friendly (eyecups that quickly pop in and out) I find to be the Leica Trinovid 8 X 42. The objectives (front lenses) are large enough for good twilight viewing. They're significantly heavier than light pocket binoculars, but always worth it to me. Sitting on a hillside watching a river or a hawk, you fly out of your body.

—SB

## Leica Trinovid 8 x 42 Binoculars

\$995

from, for example, Ben Meadows  
www.benmeadows.com  
800/241-6401



## Travelpro Rollboards

The original rollboard luggage is still the best, not least because the extendable handle unlocks with one hand on the handle. No bending over to release a lock with your other hand while your shoulder pack falls off your shoulder, adding further unwelcome drama to your episode with the airport security check. Since there are now so many rollboards out there, most of them black, I add bright yellow bookbinders tape wrapped around the lifting handle of my bags. A huge duffel bag with wheels is sometimes necessary for the long or multipurpose trip, and in this I prefer Travelpro's offerings as well. So I have a quiver of three bags—a small 18-incher for the overnight trip, a 22-incher with suit press that still can be carried aboard on most flights, and a 30-inch duffel for checking everything I might want or might want to bring home.

—SB

18" Crew 3 Rollboard, \$160  
22" Crew 3 Rollboard Expandable Suiter, \$200  
30" Crew 3 Rolling Duffel, \$160  
from such as  
www.ebags.com,  
800/820-6126



## The Secret Museum of Mankind

### Ethnic Music Classics: 1925-48

These disks contain some of the most potent music ever captured by technology. At the very instant that the phonograph began its spread around the planet, it also began to alter people's music forever. Thus, the very first recordings of indigenous folk music were in some ways the last recordings of this music. Each of the volumes in this series features musical gems rescued off of rare 78 records from that exploratory period. The music is exotic—at once refined, but raw, well-polished, but unknown (that's the secret museum)—music that at times is almost unearthly in its diverse "otherness." If music were living species, most pop would be raccoons and foxes. These pieces are wombats, century palms, and birds of paradise. Of the five volumes, the first packs the most wallop.

—KK

## The Secret Museum of Mankind

### Ethnic Music Classics: 1925-48

Volumes 1-5  
1995, CD  
\$13.95 each  
Yazoo Blues Mailorder  
973/292-9519  
http://yazoo blues  
mailorder.com/yaz7004.htm

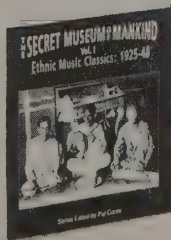

Nowadays, with increasing fervor, we are only beginning to examine the content of those recordings, be they in-situ or against the unnatural backdrop of a studio setting. What phono-archaeology has taught us is, on one hand, the commercial forays into the field of traditional music had arrested the decay of old-fashioned styles and song for all to enjoy today, and in some manner prolong their life in the community from which it originated. On the other hand, vanishing repertoires that had no lasting value to the communities themselves were likewise frozen in time, and lend an exaggerated view to us today. (An example of this is the failed [commercially] expedition to Indonesia by Beka in 1927. The popular tunes that circulated by gamelan orchestras from village to village had a short lifespan; perhaps a few weeks or little more. The villagers, the intended record-buying public, found it difficult to fathom the permanence of such recordings when the group's music was so easily accessible in the flesh, and moreover, a "now-obsolete" tune.) —Pat Conte, at the Secret Museum

## World Heritage Sites

I've slowly clued into the fact that there is a network of "World Heritage" monuments, sites, and natural parks throughout the world—places that are deemed unique enough, or endangered enough, to deserve funding by UNESCO. A site can be a monument, a group of buildings, or an entire city. But to be granted a World Heritage designation, it must "represent a masterpiece of human creative genius; or bear a unique or at least exceptional testimony to a cultural tradition or to a civilization which is living or which has disappeared."

I like to think of these creations as the Best of Civilization.

Almost every country has at least one site, and sometimes many. Some places are justifiably famous, but many are mysteriously overlooked. Heritage sites are always among the most interesting destinations to visit in any country, well worth going out of your way to see. The sites range from ruins like the famous Inca Machu Picchu, to the less known ancient city of Fatehpur Sikri, India, to preserved towns like Visby, Sweden, to unspoiled wilderness areas like the Galápagos Islands. In total UNESCO lists 630 sites in 100 countries.

In my travels I've learned to seek them out. —KK

For a full list, and criteria, check their Web site:  
www.unesco.org/whc/heritage.htm#debut

### BULGARIA (Year added to list)

- 1979 Boyana Church
- 1979 Madara Rider
- 1979 Rock-hewn Churches of Ivanovo
- 1979 Thracian Tomb of Kazanlik
- 1983 Ancient City of Nessebar
- 1983 Srebarna Nature Reserve
- 1983 Pirin National Park
- 1983 Rila Monastery
- 1985 Thracian Tomb of Sveshtari

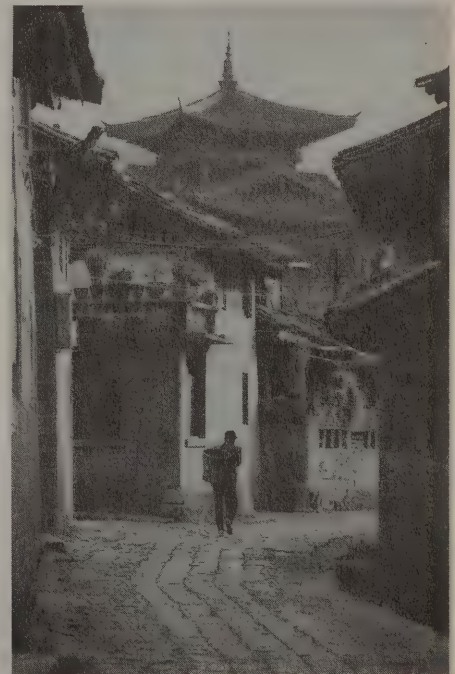

Old City of Lijiang, China. A trading town in the highlands of southwestern China. A World Heritage site.





## Sadhus India's Mystic Holy Men

*I am a sucker for big colorful portals into other worlds. (See next two items.) One of the strangest, most exotic subcultures on Earth is that of the Sadhus of India. These wandering spiritual hoboes are famous as "fakirs"—strange fellows living naked, sleeping on beds of nails, or standing on one foot for years. Most Sadhus, of course, are not so extreme; they are sort of poor priests without parish or home, but they do have their own widespread culture. Even within India, the Sadhus are considered essential outsiders, and the logic beneath their stoicism and voluntary poverty is relatively misunderstood. (A poverty more extreme than the rural poor, and deliberate.) They seem to me from my own personal encounters with them to be situated directly opposite the dot-com-ers—the fast-forward online culture of the Web. Both clans are essentially nomadic and urban, but each is the inverse of the other. The surprising news is that there are an estimated two million adherents to this subculture, probably more than there are high-tech digerati, and yet they are off the global radar entirely. We are often amazed by radical behavior of cultures past, yet here is one as close as the nearest airport. Even better, the nearest bookstore holds this book, which will give you a far better, more informed (and more colorful!) picture than several months of traveling. I've found no comparable work on the subject.*

—KK

**Sadhus**  
**India's Mystic Holy Men**  
Dolf Hartsuiker  
1993, 128 pages  
\$20  
Inner Traditions  
International



Bajrang Das, a disciple of Bhagawan Das, has been standing now for six years. He also wears a metal "chastity belt," and is a "non-speaker" and a "fruit-eater," too. Khareshwaris may walk about, but they usually just hang in their swing in their corner—and stand.

Hari Govinda Singh rubs earth on his penis, firmly ties the sling of cloth, stretches his legs and lifts the stones. It is a "miracle" that the penis is not torn off.



The first stage of the "five-fire-austerity" involves five heaps of smoldering cow dung. In the following stages the number of fires increases to seven, twelve, eighty-four, and "innumerable," until in the final stage a pot with fire is balanced on the head. Each stage is performed for three consecutive summers, so the complete cycle takes eighteen years.





## African Ceremonies

*One doesn't read this; one falls into it, like an experience. Printed in lavish color in large format, this two-volume celebration of contemporary ritual in Africa is shocking in its lushness. It seems to explode with possibilities—of what ritual and ceremony could be, of how many different ways there are to find meaning in life. It also presents the best argument for why Africa should not be written off: it has difference, and difference is the engine behind innovation. Although expensive, this box set is cheaper than a rocket ship to another galaxy—which is the only other thing I can imagine having similar effect of this work.*

*Two remarkable women, who first started photographing the jewelry of Africa, developed these books over decades of fieldwork. Some of their work has been published in National Geographic and their other books. Beside eye-popping photos, there is outstanding text on what is pictured. This is spectacle with intelligence. To offset the pricey cost of this magnum opus, their publisher has recently issued a paperback selection called Passages: Photographs in Africa, which presents highlights from Ceremonies. But this abridgement has only one-tenth the 850 images in Ceremonies, and I feel it misses the point of the larger work: glorious, extravagant diversity.*

—KK

### African Ceremonies

Carol Beckwith, Angela Fisher  
1999, 744 pages (two volumes)  
\$150  
Harry N. Abrams

### Passages

**Photographs in Africa**  
Carol Beckwith, Angela Fisher  
2000, 112 pages  
\$24.95  
Harry N. Abrams



Wearing costumes fashioned from hibiscus fibers and cowrie shells, and with coconut shells as breasts, dancers on stilts rest before performing. Their teetering dance and flapping arm movements imitate a long-legged water bird, but it is also mischievously said that their antics mimic their neighbors, the tall, pointy-breasted Fulani women.

Katjambia summons all her powers to draw the lion spirit out of the woman. Her eyes roll back and she enters a trance, absorbing the evil force into her own body. Forced into Katjambia's body, the lion spirit remains so powerful that she is unable to expel it no matter how she tries. Barely able to speak, she whispers that she must retreat to her family village to call on the help of ancestral spirits contained in the sacred fire.

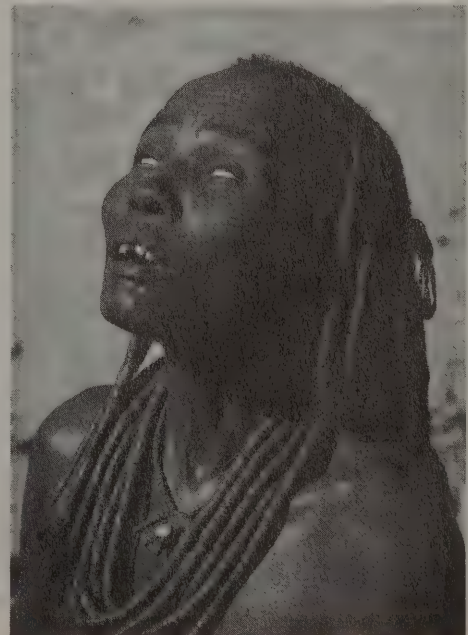





## Fantasy Worlds

Sometimes, despite all pressures toward normalcy, people are compelled to construct their own worlds. The old lady who over the years arranges broken bottles into a house, or the man down the road covering his barn with tiny quotes from a channeling spirit—each glues raw symbols into a whole that makes sense for them. This happens all over the world. I've collected an entire stack of books about self-made worlds, and this one is the best for sheer exuberance, geographic inclusion, and variety. Science fiction author William Gibson says these worlds remind him of elaborate personal Web sites—and vice versa. Web sites are really self-made worlds; to me they are distant lands, with their own cultures.

—KK

### Fantasy Worlds

Deidi von Schaewen, et al  
1999, 340 pages  
\$40  
Taschen



## Rough Guide World Music

Travel with your ears. This comprehensive, massive (700-plus pages), and recently updated two-volume guide to global song covers the planet, from Norwegian fiddlers to Filipino folk rockers. It's all here: what kind of music is out there, where it came from, who is playing it, and where to get it. Feeling stuck? Open up this book at random, order a CD, and enter another way of seeing.

—KK

### Rough Guide World Music

Vol. 1: Africa, Europe, Mid East  
Vol. 2: Latin American, India, Asia, Pacific  
2000 (2nd edition),  
Vol. 1, 736 pages,  
Vol 2, 720 pages  
\$26.95 each  
Rough Guides

*Indonesian Pop*  
Moluccan Moods Orchestra  
(Piranha, Germany). If you haven't heard of the Moluccans since they held up Dutch trains in the 1970s, give this disc a listen. Traditional songs arranged in laid-back style with exciting percussion, keyboards, saxophone and flute.

*Zambian Pop*  
From the Copperbelt...Zambian Miner's Songs (Original Music, US). In the "African Acoustic" series, eighteen interesting-to-beautiful songs by the mine camp entertainers of the copper-belt that straddles Zambia and southeastern Zaire, field-recorded by ethno-musicologist Hugh Tracey in 1957.

*Albanian*  
Famille Lela De Permet  
Polyphonies vocales et instrumentales d'Albanie (Indigo/Harmonia Mundi, France). Beautiful and approachable songs and instrumental music from the Permet and Korce regions of southern Albania. Wailing and sliding clarinets give this music an enchanting mournful sound.

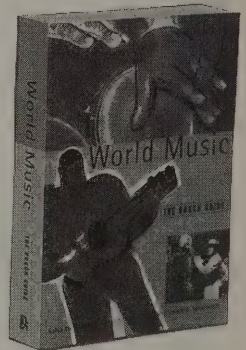



## The Alan Lomax Collection

If you want a cheap one-way ticket into global folk music, a path that continues a long way, you want the Alan Lomax Collection Sampler disc. For a few dollars you can buy the best of a national treasure. In the 1950s folklorist Alan Lomax began the systematic field recording of folk songs in the US, Europe and the West Indies. His microphone picked up sea chants, dance reels, peddler calls, hymns from the American Deep South, calypsos, Negro spirituals, and a dizzying variety of European folk styles (which are not at all what you'd expect—they sound oriental and medieval).

Lomax's peerless ethnomusic archive was until recently difficult to access. Now Rounder Records has reissued his collection as a massive forty-CD series, The Alan Lomax Collection. The quantity and quality of this achievement is vast and world-class.

For most humans, the Sampler is a good start—an amazing, ear-tickling gathering of thirty-seven pieces of highly evolved, but sadly ephemeral, culture.

A Romance singer in Asturias, the most mountainous province of Spain. Asturians sing the classical romances(ballads) of central Spain, retaining lyrics dating from the fifteenth century.



Further wonderfulness can be found in the other forty discs dedicated to say, *Prison Songs* (two volumes), or the ballads of black cowboys known as *Black Texans*, or the sacred harp music of white Baptist churches. Boredom will not be a problem; Epiphany will be likely.

—KK

### The Alan Lomax Collection Sampler

1997  
CD, \$16.97  
Rounder  
rounder.com

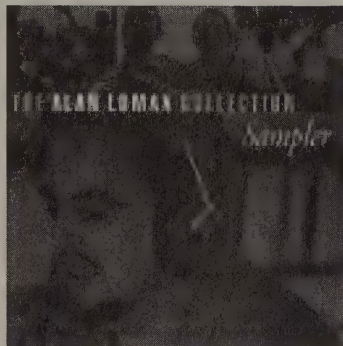

Day after day I turned up ancient folk song genres totally unknown to my colleagues in Rome. By chance I happened to be the first person to record in the field over the whole Italian countryside, and I began to understand how the men of the Renaissance must have felt upon discovering the buried and hidden treasure of classical Greek and Roman antiquity. In a sense, I was a kind of musical Columbus in reverse. Nor had I arrived on the scene a moment too soon. —Alan Lomax, from the inside booklet of "Folk Music and Song of Italy; A Sampler"

## Jean Shepherd

When I was growing up as a kid in the 1960s, I listened to legendary storyteller Jean Shepherd spin wild, maniacal yarns every night for forty-five minutes on our local radio station near New York City. Shepherd told outrageous tales from his experiences working in the steel mills of Gary, Indiana, of his teenage exploits with hot rod cars, of the crazy boredom of his army life, and of his life as swinger in Greenwich Village. Imagine Walt Whitman as a comedian, or Garrison Keillor as a beatnik, and you might come close, but you'd miss the way Shepherd creatively hacked the medium of radio, doing things with it that would not be commonplace until the talk show era decades later. (Shepherd once got his audience to force a fictional book onto the New York Times's best seller list.) I kept thinking over the years, "I sure hope someone out there is recording these." Well, many people were. Jean Shepherd died last year, but now his stories live on via the Web and cassettes.

With thousands of broadcasts, it's hard to know where to start. Shepherd was at his peak in the mid-1960s, and his "Live at the Limelight" shows are always great, but you can get a feel for what it was like listening to him through the evening static of WOR-AM by clicking on the weekly re-broadcasts of his show on the Web. Check out the fabulous Shepherd fan site, [www.flicklives.com](http://www.flicklives.com) (Web radio: [www.flicklives.com/mass\\_back.htm](http://www.flicklives.com/mass_back.htm)), or see the catalog of tapes at [www.oldtimeradio.com](http://www.oldtimeradio.com), which also has a steady stream of other old-time radio shows.

—KK

### Jean Shepherd Tapes

Free catalog  
Max Schmid  
PO Box 3449  
Astoria, NY 11103  
[www.oldtimeradio.com](http://www.oldtimeradio.com)  
[www.flicklives.com](http://www.flicklives.com)

"Can you imagine 4,000 years passing, and you're not even a memory? Think about it, friends. It's not just a possibility. It is a certainty."

—Jean Shepherd, 1975

## Listen to This!

### Leading Musicians Recommend Their Favorite Artists and Recordings

I'm such a wimp when it comes to exploring pop music I don't know. This great idea helps a bit: about 100 leading pop musicians recommend their all-time favorite artists and albums, and why they love them. The unfamiliar (to me) names that come up again and again are the ones I'm looking for. The best aspect of this approach is that one can glimpse something rare—artists talking about their musical influences. Who wouldn't want to study the record collection of say, Herbie Hancock, or Pat Metheny?

—KK

### Listen to This!

#### Leading Musicians Recommend Their Favorite Artists and Recordings

Alan Reeder and John Baxter  
1999, 466 pages  
\$17  
Hyperion

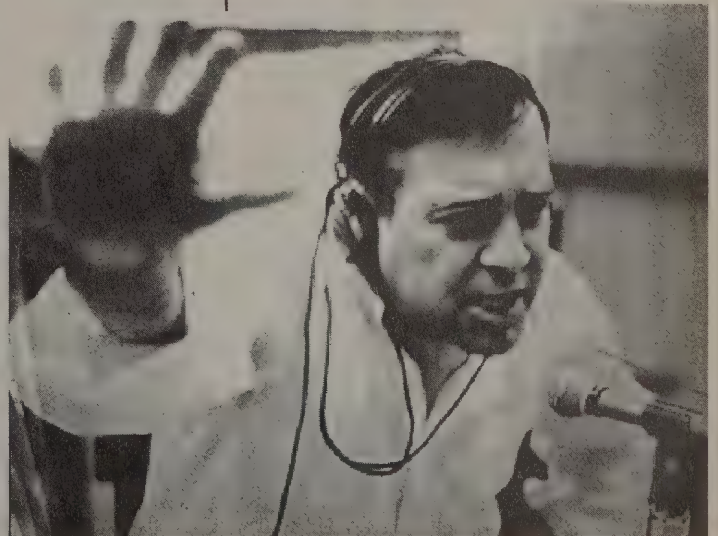
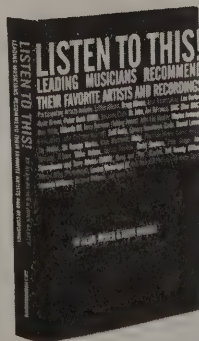



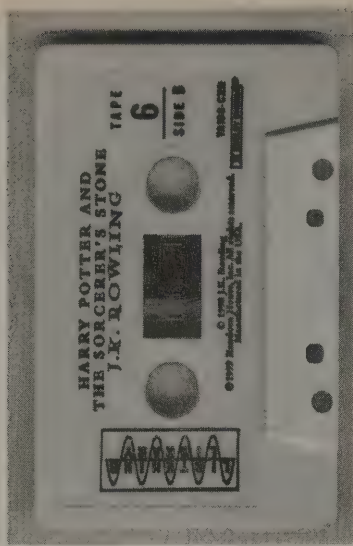

## Books on Tape (Again)

Whenever I overhear a complaint of someone's long time-wasting commute I want to shout, "It doesn't have to be that way. You can read books while you drive!" By "read," I quickly add, I mean listening. Books on tape aren't new, but they aren't as common as they should be. Which is a shame because the selection of books available for auditing continues to expand, their relative price continues to drop, and the venues where they can be rented or bought continue to increase. Many public libraries have decent collections, more online bookstores sell them, and now many titles are available on CD. I've read, oh I suppose, hundreds of books this way. And I've met others likewise initiated into this underground. Here's what we know about how to maximize this great medium.

1) Being read to is a pleasure. Hearing a book instead of "watching" it can be a powerful experience.

2) Start with a good story. If you have never listened to a book on tape before, pick what you know is a good tale to begin with. You can always get to that self-help or executive summary later. Try the Pulitzer-winning novel *Lonesome Dove* for a memorable treat.

3) If at all possible choose an unabridged version. The unabridged is how the author wanted you to get his/her story. One of the delights about books on tape is that they are far more leisurely (reading aloud takes longer), so you can exploit this pace by getting the full unexpurgated version. As a rule of thumb, most unabridged books will require at least eight cassettes at minimum, with very long ones like *Peter the Great* taking up to forty or more. Many of the books on tape for sale in bookstores are slim two- or four-cassette abbreviated versions. I consider these a second choice.

4) If a book is only available in an abridged version, it can still be enjoyable. Very rarely, it can be better. Cyberpunk author William Gibson actually prefers the abridged audio

version of his book *Neuromancer*. Occasionally I've deliberately chosen an abbreviated version because I just didn't want to sit through the long edition. Still, a book worth reading is usually worth the original text.

5) Avoid dramatizations. These were in vogue for a while but luckily they've mostly disappeared. More than one person acts out the dialog, but the histrionic tone usually turns a book into theater. There is something incredibly satisfying about having one voice (with accents and drama, yes) continue through the work.

6) Narrators matter. I have learned to never listen to an author read his own work, no matter who. A professional narrator can make all the difference between a book that sings and one that dies. Good narrators can pronounce technical and foreign names exactly, and often do accents properly. Their voices don't waver or dull. But the wrong narrator can pollute a book. I will return a book if I find the narrator's voice makes me wince. Conversely, if I notice a great narrator I will now seek out the other books they have done. Narrating is a very laborious process and good narrators are in top demand, so they won't invest their time in a mediocre book. Half the spell of a book is cast by the narration.

7) With that in mind, sometimes a narrated version of a book is actually better than reading it. The example on everyone's mind these days is the Harry Potter series. I have no hesitation in saying that Jim Dale's narration of Harry Potter is better than reading it. (If you want my best candidate for a book to start out, pick any Harry Potter book and listen to it on tape; Dale's is the only version available at the moment). Dale does something like 120 different voices for the series (so far) and each one is absolutely perfect. He makes an already remarkable series of books fantastic. Another book that was better on tape than reading it was *Midnight in the Garden of Good and Evil*. Again, the narrator got the accents of these characters more exact and colorful than my reading ear could have. Russian novels are often improved by audio because they can get all those Russian names and places perfect.

8) Over the years I've found that the best books for auditing are either fiction or history. I still read a lot of nonfiction on tape, but fiction and history work best for me. Both have deep narrative structure. I choose more and more history now because I realize that I don't have the patience to read history, as in using my eyes while staring at the page. The captured-audience nature of listening (can't skip easily) demands that I follow the course all the way through. And I'm usually glad I did. So most of the history I read now, I actually audit. Happily, there are a lot of great historical books on tape.

9) Having a parallel printed copy of a book can help alleviate one of an audio book's primary weaknesses: there's no way to bookmark a passage. Stewart Brand, another audio book fanatic, will usually keep a hard copy of the

text in book form handy so that he can mark sections he wants to refer to later. I don't do that but I sure wish I could bookmark stuff.

10) You have a choice of channels. A) Cassettes are still the default. The pros: most cars have players; easy to retain your place if you take it out. Cons: break too much, too many tapes for long books. B) CDs are the up-and-coming venue. Pros: Crystal clear, compact, reliable. Cons: Lose place if you yank it out to put on some music, and not all cars have players. C) Coming soon: downloaded versions. You can already get MP3 versions of books to play on dedicated players. I confess I haven't tried any of these because tapes and CDs work well enough, but I can see the advantages clearly: very compact, very fast delivery, and possible mechanisms for bookmarking.

11) Auditing while driving is not dangerous. I don't know how it works but you can be completely engrossed in a story, while the other you somehow drives at your top skill. It's not the same as talking on a cell phone. Works best if you know exactly where you are going, like on a commute. Doesn't work if you have to navigate; you'll miss a turn for sure.

12) Rent or buy? Public libraries have gotten smart and are stocking up. You can usually find what you want via the interlibrary loan system. Book shops mostly sell. I occasionally will buy a particularly good tape and then circulate it to friends, who will do the same. It makes an informal books-on-tape lending circle. The two main sources for rental—which costs about \$10 per short book, or part of a long book—are below.

Where to start? Let's see; this summer my wife and I (on separate commutes) listened to *War & Peace*, all of it. Great book, great narration. Took three months, but worth every second. Adventures like *The Perfect Storm* and *Into Thin Air* are just right. Robert Hughes' history of Australia, *The Fatal Shore*, listened well. Occasionally I throw in some lightweight mystery or technothriller. Right now I'm auditing the *Odyssey* and the *Illiad*. You get the picture. Traffic jams are just story-time extenders. If I've got a good book, and someone to read, I'll go slow and learn something.

—KK

### Books on Tape

800-626-3333  
www.booksontape.com

### Recorded Books

880-638-1304  
www.recordedbooks.com



## Bose Acoustic Noise Cancelling Headset

*This gear has managed to turn my many long-distance airplane trips into peaceful journeys. It turns out a lot of the fatigue of long flights is the constant drum of the airplane's engines. With this magical headset on, that noise completely vanishes. Gone! In its place you can listen to music (whatever source) or just pure faint silence. For sleeping on planes, there is no better technology, including chemicals. Because of the smart design of the generous ear cups there is no ear cringe from wearing these for hours on end. In fact, they are far more comfortable than the flimsy lightweight Walkman-style earsets. Even though these weigh more, they feel better. I put them on when I board a plane and I sleep with them on, too. Tuned low to some innocuous music channel, they coo sweetly. (It's a shock to take the phones off because you can then hear how incredibly loud the plane's rumble really is.) This works so well for flights that Bose makes a special aviation set just for pilots, and a military issue helmet for soldiers working in high-decibel environments like a helicopter. All this comfort comes to you via some very clever chips that cancel out noise signals. This pricey set make perfectly wonderful earphones for land as well, particularly if you need to listen anywhere there is a lot of background distractions. I haven't yet tried it in a shop environment, or while mowing the grass, but I will.*

*This is really one of those things you have to hear to believe. Bose has a thirty-day free trial period. Take them up on their offer next time you have a fourteen-hour flight and see if it works for you.*

—KK

## Bose Acoustic Noise Cancelling Headset

\$300  
Bose  
800-999-2673  
www.bose.com

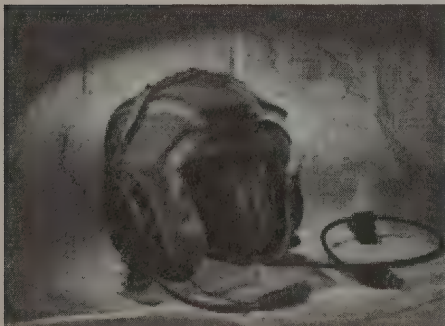
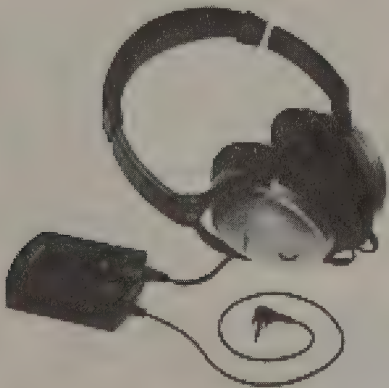

## BlackBerry

*A cell phone is too disruptive, and a pager is too one-way. That's why I avoid them. But a two-way pager that could do proper e-mail, now there's a tool! That's what you get with the BlackBerry, and that is why this little belt device is sweeping the world of road warriors. Unlike a cell phone, it is always on. Yet it doesn't demand immediate attention. And you can send or receive in silence, or even while you are supposed to be doing something else (listening to a boring meeting). Typing is all thumbs, but it is remarkable how fast you can go. Covers the metropolitan areas of the US and Canada. It is the next big little thing.*

—KK

## BlackBerry

RIM 950 Wireless Handheld  
Basic unit starts at \$349  
Basic wireless e-mail service starts at \$39 per month  
RIM  
877/255-2377  
www.blackberry.net

## Good Cheap Almost New Cars

*You can get a Geo Prizm, one year old and 20K miles, for about \$9,000. They can be bought at auction for the lowest price from a car rental firm, after they have served their year of rental service. Geo Prizms are good and reliable. They come off the same assembly line as Toyota Corollas, and are essentially the same car. Prizms give you Toyota reliability and quality but they don't command the high Toyota price.*

—Ted Kaehler



## Honda EU Series Generators

*These generators are ridiculously quiet. The secret, as I understand it, is that they are low-volt 12v DC generators that take advantage of the new, very efficient inverter technology to produce the needed 120v AC. There are two sizes to choose from in the EU series (Honda's quietest and most efficient): 1,000 or 3,000 watts. Both have the ability to be hooked up to another generator to double the rating. The 1,000-watt model weighs less than 30 lbs., fits in a trunk, and can power a few appliances. On the other hand, I have used the 140-lb., 3,000-watt generator to power a camp of twenty people in the desert, including a full sound system, for ten days round the clock, and it hardly was breathing hard at all. With an optional cord you can use the 12v DC current directly to charge batteries. These generators also automatically shut off if they get low on oil. They have electric start with pull-start backup. Best of all they completely decimate the track record for efficiency of most gas genys. Instead of the usual one gallon per hour they can operate for between seven and twenty-four hours (depending on load) on a single 3.5-gallon tank. In short, they take all the usual horrors and worries out of using generators.*

—Alexander Rose

## Honda EU Series Generators

EU 1000, \$700 street price  
EU3000is, \$1,750 street price  
www.honda-generators.com/generators  
or  
www.generatorsale.com



## TalkAbouts

*Cheaper than cell phones; indispensable when outdoors. The most inexpensive mobile communications for short distances—up to two miles. If you are putting on a conference, an outdoor event, or traveling with a team, these rugged units are the things to have. They are inexpensive enough to ensure everyone on a team has one.*

—KK

## Motorola TalkAbouts

Beginning at about \$50  
Motorola, Inc.  
www.motorola.com



# Home Comforts

## The Art & Science of Keeping House

*This appears to be a book of tips for housekeeping, but it is as much about housekeeping as Moby Dick is about fishing. It's about doing mindless chores mindfully. If you cook, clean, and dress, why not do it with full knowledge of what the most scientific method is? There is something attractively nerdy about Mendelson's obsession with getting to a deep technical understanding of whatever needs to be done. So much good-spirited lore swims in this book, that you can pick it up anywhere and find yourself reading hours later about the absolute best way to iron. Ordinary chores are given a new life. I haven't seen such behavior-changing information in ages. I'm thinking I'll give each of my kids a copy when they depart for their own places.*

—KK

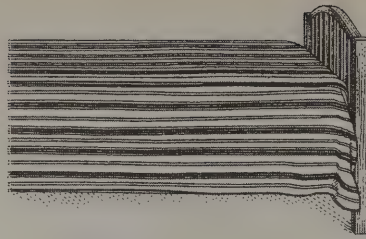
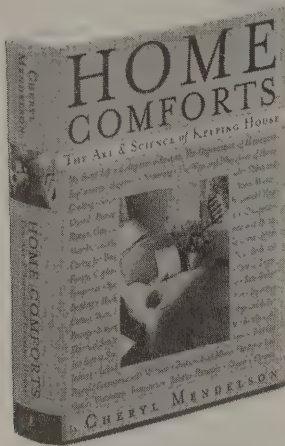

Bottom tucked in

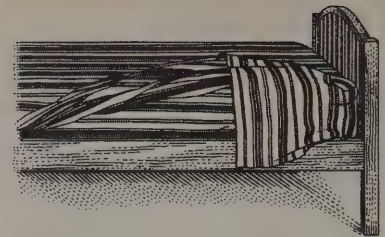

Side pulled up

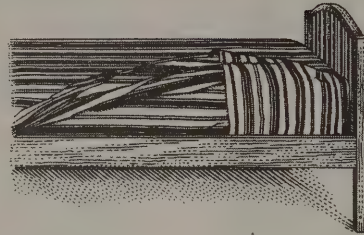

Hanging-down portion of side tucked in

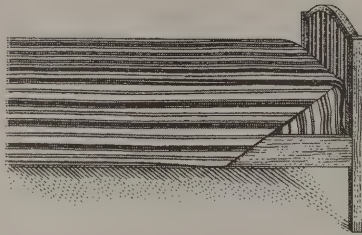

Side hanging down

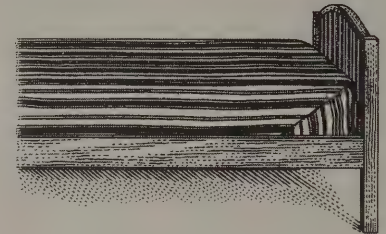

Tuck-in of entire side of sheet (optional on top sheet)

How to make “mitered” or “hospital” corners

### Home Comforts

#### The Art & Science of Keeping House

Cheryl Mendelson

1999, 884 pages

\$35

Scribner

The terms “ironing” and “pressing” are often used interchangeably, but they are in fact different things. In ironing, you slide the iron back and forth over the cloth; in pressing, you simply press the iron in one spot and then lift it. Pressing is used on tailored and lined suits, especially on men’s, on wool, on silk and some rayon, on net, and on pile fabrics. Pressing is used to avoid crushing the cloth, giving it a shine, or stretching or scorching or otherwise harming it with the heat of the iron. This is done partly by not sliding the iron and partly (and usually) by using a “pressing cloth.” This is simply a cloth that you lay over the fabric, pressing through it rather than touching the iron directly to the garment.

Washing the Dishes. Begin with perfectly clean, hot, sudsy water. Wash the dishes that are least soiled first and progress to those that are most soiled, as this entails the fewest changes of water. As noted above, you usually begin with glass and silver or flatware, which need very hot water so that they dry quickly without streaks or spots.

As an experiment, I once sorted my laundry according to the exact instructions on the care labels. Although in quantity I had enough to make up three or four good-sized loads, if I had obeyed the labels I would have had to wash at least three times that

many loads, as practically no two garments were labeled identically. No experienced home launderer actually washes twelve or more loads instead of four. Thus we all become care label skeptics, defying the labels without hesitation.

Inaccurate labeling and “low labeling” (labels that prescribe more conservative care than the garment really needs) are both quite common. Nonetheless, some of our skepticism about labels is in fact mistaken. We may fail to recognize that a label is accurate if (for example) a garment labeled “Dry-clean only” seems perfectly all right after being laundered. The effects of laundering may become apparent only after the third or fourth wash, and those effects may include shrinkage, fading, weakening, or the loss of beneficial treatments and finishes. By the time you discover that the label was right all along, it is too late to save the garment.

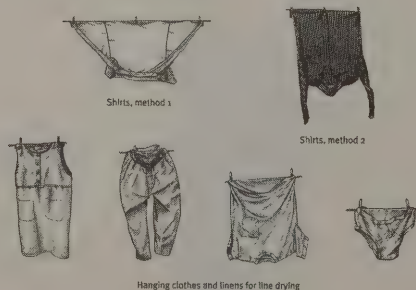

Shirts, method 1

Shirts, method 2

Hanging clothes and linens for line drying

## Smarthome.com

*Here it comes, ready or not: the Smart House. A whole avalanche of products in mind-numbing diversity is available via this mail-order catalog and Web site. A lot of the equipment I find creepy (networks of concealed in-house mini-video cameras for “security” purposes), but some I covet right now (I want to be able to beep my front door open like I beep my car door open; \$69 uninstalled). The rest can wait (the caller ID of your incoming phone call shows up on your TV). The avalanche is only picking up speed and this catalog, which has the widest collection I’ve seen, is the best way to keep up.*

—KK

### Smarthome.com

800/762-7846

949/221-9200

www.smarthome.com

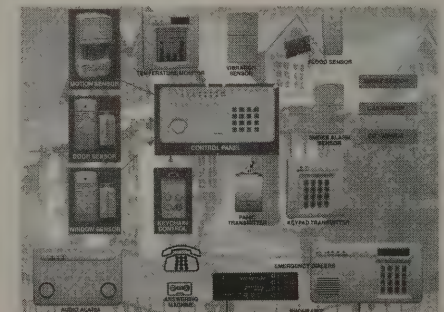



# The Gardener's Guide to Growing Temperate Bamboos

You can grow bamboo where you live. This exceptionally clear guide deals with the nitty-gritty of bamboo cultivation and propagation and covers about 200 varieties suited to temperate regions. Lots of color photos help identification. Great book. The bamboo in our garden won't stop. Long live bamboo!

—KK

## The Gardener's Guide to Growing Temperate Bamboos

Michael Bell  
2000, 159 pages  
\$30  
Timber Press  
800/ 327-5680  
www.timberpress.com

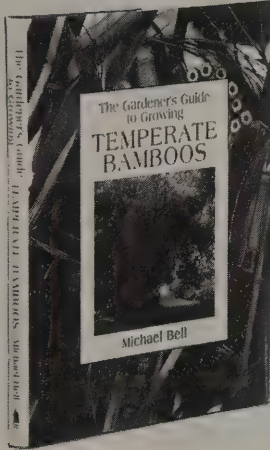

### PLATE IV

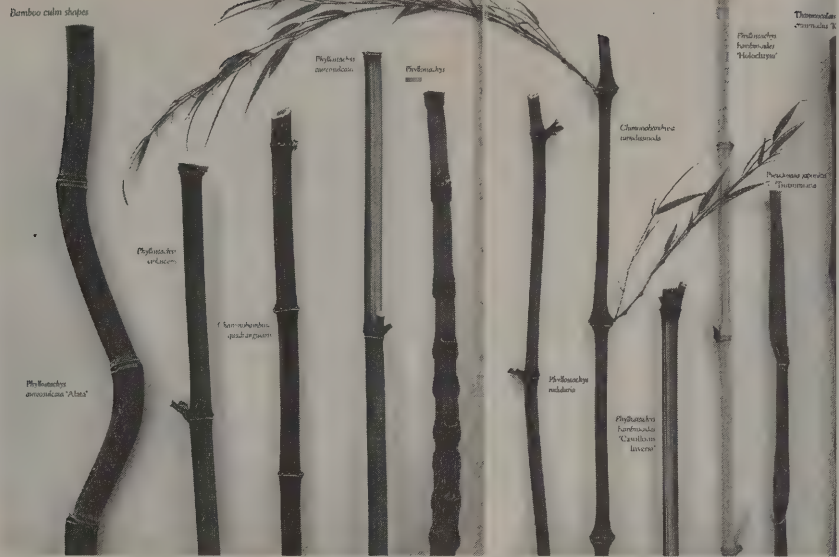

Those new to bamboos always find it an anomaly that, despite the fact that they are known to be the fastest-growing of plants, they are among the more expensive to buy, and are not available in huge quantities. There is good reason for this, however. The more desirable garden bamboos are, naturally, those that grow slowly at the root and have rapid vertical growth. The slow rate of root growth means that the best one can hope for is that the plant will approximately double its size every year. Therefore, for every plant in a nursery, one can expect to get only one similar-sized division per year, not allowing for any propagation failures or for the plant to increase in size.

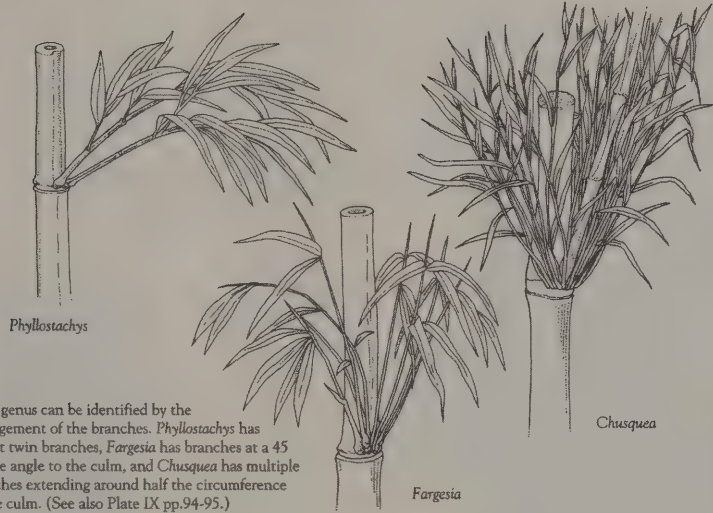

Each genus can be identified by the arrangement of the branches. *Phyllostachys* has robust twin branches, *Fargesia* has branches at a 45 degree angle to the culm, and *Chusquea* has multiple branches extending around half the circumference of the culm. (See also Plate IX pp.94-95.)

## Building Bamboo Fences

Step-by-step instructions for making scores of stylized ornamental bamboo fences. From Japan where they take this art seriously. Bamboo can grow anywhere most trees grow and is ideally suited to fence making.

—KK

### Building Bamboo Fences

Isao Yoshikawa  
1999, 142 pages  
\$28  
Graphic-sha Publishing Co.  
Distributed by Kodansha International

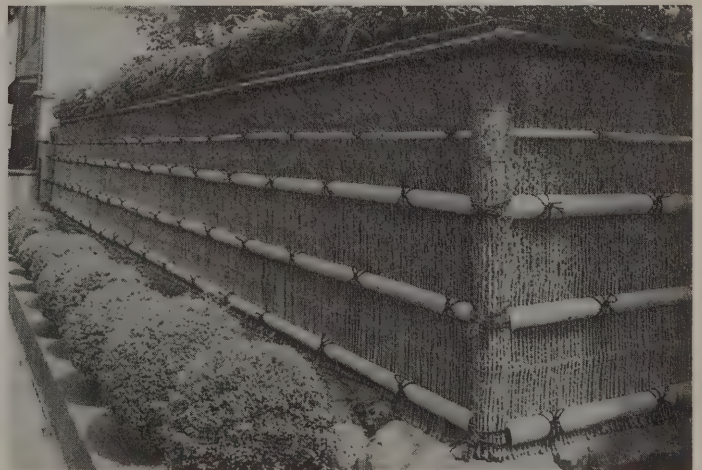
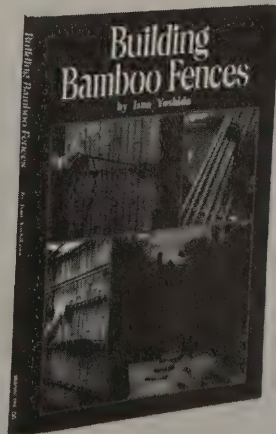



## Self Reliance Journal

In this latest incarnation of a survivalist magazine, the two strands of the self-reliance movement are mixed up here with the glee of cognitive dissonance. You've got your pure survivalists, who run away from things (the govmint, Y2K, society in general), and now you've also got the greens, who run to society (rural values, ecotopia). So in one issue you'll get articles on solar-powered yurts, making your own soap, and the best "combat flashlights" used to temporarily blind an assailant, or software for training your long-range rifle skills. In between is material on outfitting four-wheel drives, diving for legal abalone, AC inverters, building your own home and other matters of living close to the land away from the crowd.

—KK

### Self Reliance Journal

\$25.97, 1 year (12 issues)  
PO Box 68040  
Anaheim, CA 92817-9800  
800-999-9718

### Power Generator Lanterns

The new Liberty Power Generator unit is attached to the top of a lantern and heat from the lantern's flame produces enough electricity to run a portable AM/FM/short wave radio for as little as 1 cent per hour, providing a valuable alternative to battery power for radio communication or other electric needs. The generator has no moving parts to wear out, no batteries and needs no external power source, only the heat from the lantern's flame.

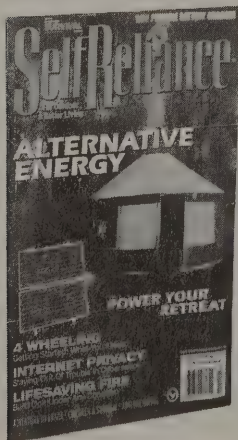
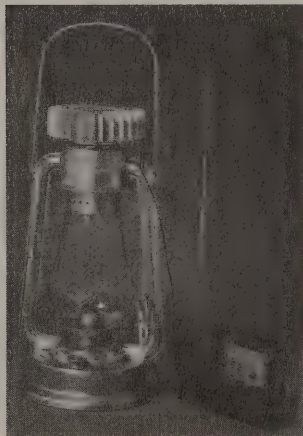

## Handmade Houseboats

*Oh, it's an ancient yearning. I lived on a houseboat once; you definitely need more than a log raft. But you don't need a million dollars more. The techniques here rely on modern materials (barrels and composting toilets), and cover all aspects of building and maintaining a floating cottage, mindful of the constant threat that constant water presents. In my experience, however, the main hurdle is not construction, but finding a place to dock. If you have a location, you can build it.*

—KK

### Handmade Houseboats Independent Living Afloat

Russell Conder  
1992, 230 pages  
\$19.95  
McGraw-Hill  
800-822-8158

#### Are You Crazy?

This book is about how to build your own houseboat, and thereby sidestep the twin ogres of twentieth-century survival: mortgages and landlords. If you can hold these pages open, dear reader, then you have the manual dexterity to hold a hammer. If you can do that, then armed with this book and a smidgen of imagination, and at least a little gumption, you can build your own floating home, and be comfortably ensconced inside it, within a few weeks.

Steel barrels are the cheapest option; however, they will eventually rust away. Where wind and water meet, there is enough readily replaced oxygen being thrown promiscuously about to equip the intensive-care unit of any hospital. Oxygen is one of the most corrosive elements known, and it will attack steel houseboat barrels with glee. Not only do the drums deteriorate, but flakes of rust fall into the mud and sand, poisoning the benign environment where minuscule creepy-crawlies used to live, before the kamikaze debris started to rain down. If you have acquired a houseboat with steel drums, they'll undoubtedly need replacing soon. If you are building a new house and choose steel for reasons of economy, you are simply putting off the painful necessity of opening your wallet and buying plastic barrels, which will last as long as the houseboat does.



Figures 2-6. Barrels beneath a raft frame support the 54-foot houseboat shown in Figure 2-7.

Ordinary plastic barrels are readily found, and they are strong and durable. Due to their rounded shape, they will support the weight of a house, on the shore or afloat. The plastic barrel compresses as load is applied; that is, it transfers the load away along its curve, rather than attempting to support the weight in one place and then breaking, like a flat surface will. All a plastic barrel requires in the way of consideration is that it be placed out of, or protected from, the direct rays of the sun: Ultraviolet light will eventually weaken the material and cause it to become brittle. This should not be a problem with houseboats, for the barrels are placed underneath the raft, in the shade.

Houseboats can be designed to float in as little as 6 inches of water, so finding a suitable site should not be a problem.

Enclosed is a photo of my little 18'x7' houseboat. Designed by William Atkin in the 1940s, she was built in 1985 by David Scarborough of Rock Hall Boats: cedar-planked, fiberglassed to the waterline, canvas-covered plywood deck, plywood house, powered by a 9.9 outboard. I had her built as a weekend retreat, but before completion, I had a stroke. When I recovered enough to live alone, I moved to the St. Johns River in Florida and have lived aboard since 1987. (Beats living in a nursing home.)





## Making the Best of Basics

*I did absolutely zero to prepare for Y2K. I mean nothing. No extra gas in the car, no canned food, no extra cash, no extra milk or water. Nada. But now that the apocalyptic hysteria is over, and no one expects Armageddon, I'm convinced this is the time to treat preparedness seriously. This dense workbook has long been considered the bible of the food storage and family preparedness crowd. Preparedness as in: be ready for any long-term disaster or crisis. A newly revised and expanded 10th edition has everything from how to store the basics (and how much), to how to cook 'em, and how to keep water and stay healthy. Up-to-date and exhaustive. Yeah, it's from Utah, so it dispenses well-worn, almost comfortable, anxiety.*

—KK

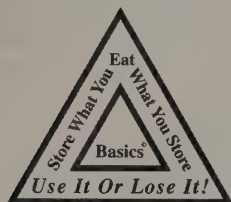

Water that is bacteria-free when stored in thoroughly clean containers will remain safe for several years. Tests of water quality after long-term storage showed that water stored properly for several years could not be distinguished by appearance, taste, or odor from water recently drawn from the same source. However the principle of rotation is the best guarantee for monitoring stored water's purity and taste.

### Treating Contaminated Water

#### Basic Bleach Method

For emergency treating of water of unknown quality, use any household bleach containing sodium hypochlorite (5.25% solution) without soap additives or phosphates. By using common household bleach as a chemical treatment method, large amounts of safe drinking water can be provided quite inexpensively.

Inventory management for basic in-home food storage is very simple—and hopefully, by now, very familiar:

- 1) Store what you eat.
- 2) Eat what you store.
- 3) Use it or lose it!

### Fumigating Wheat for Storage

Carbon dioxide released from evaporating dry ice will kill all animal life in the container. The freezer will kill all live bugs—but not necessarily the eggs—over an extended period of time. It's always best to refreeze the previously frozen wheat after 30 days to assure that any eggs hatched since the last treatment are killed.

## Making the Best of Basics

### Family Preparedness Handbook

James Talmage Stevens  
1997, 10th Edition,  
237 pages  
\$22.95  
Gold Leaf Press

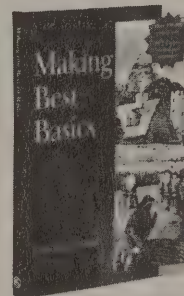

## Penzeys Spices

*The spices of life. All of them, in subtle variations, from around the world. By mailorder.*

—KK

### Penzeys Spices

Muskego, WI 53150, 800-741-7787  
www.penzeys.com

#### Saffron

Saffron is the stigma of the fall flowering crocus. Peek inside most any flower and you will see three threadlike filaments. These are stigma—but only in the saffron crocus are these stigma worth thousands of dollars per pound. Saffron is so valuable because it is a very labor intensive crop; only 5–7 pounds of saffron can be produced from each acre of land. This makes saffron the most expensive spice by weight—it has always been—but by use saffron isn't that expensive, because a little goes a long way. A single gram of saffron easily translates into golden color and fragrant flavor.

Saffron contains 450–500 saffron stigmas to the gram. The stigma are also called threads, strings, pieces or strands. 1 gram equals 2 tsp. whole, 1 teaspoon crumbled or 1/2 teaspoon powdered. Don't buy pre-powdered saffron because it loses flavor quickly and is usually cut with turmeric or something else.

#### Mace

Mace, the lace-like, dried covering of the nutmeg, is a sweet and flavorful spice well worth using. Mace has a softer flavor than nutmeg, and for a nice change of pace it can be used in place of nutmeg in any recipe. Blade Mace can also be added to clear soups and sauces where nutmeg powder might spoil the appearance. Mace is a traditional flavoring for doughnuts and hotdogs.

#### Ajwain Seed

Ajwain (or Ajowan) is a traditional addition to many Indian and Pakistani dishes. It's especially useful in vegetarian lentil and bean dishes, as a flavoring, and to temper the effects of a legume-based diet. From Pakistan.

50113 1 lb bag 13.90

50184 8 oz bag 7.49

50142 4 oz bag 4.29



**Kashmir Mogra Cream Saffron**

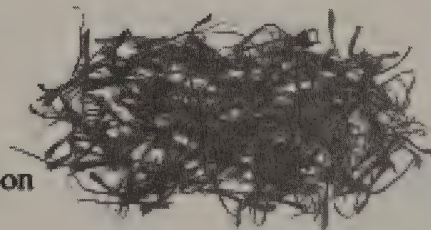

**Coupé Spanish Saffron**

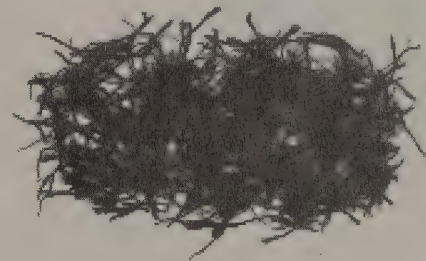

**Superior Spanish Saffron**

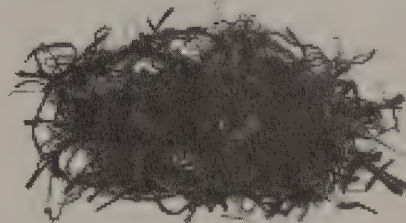

**Kashmir "Mogra Cream" Indian Saffron** is the world's finest saffron. The dark red color and long perfect strands are as beautiful as they are colorful and flavorful. Kashmir saffron is awfully tough to obtain, which makes it higher in price, but Kashmir Mogra Cream Saffron is truly wonderful.

**Spanish Coupé Saffron** is the top grade of the Spanish Saffron crop. Extra hand labor is used to remove every bit of the yellow saffron style material, leaving 100% beautiful pure red saffron threads—hence the name: coupé means "to cut", as in cutting off all the yellow bits. Spanish Coupé Saffron is a truly excellent crop, especially nice for the traditional Spanish dishes.

**Spanish Superior Saffron** is the most widely available saffron and is a very good crop. Spanish Superior Saffron has a bit of the yellow style material left attached to some of the saffron stigmas (see photo), so it is not quite as strong as Spanish Coupé or Kashmir Indian Saffron.



## Ultimate Fit or Fat

The classic book on fitness has been rewritten after twenty-five years and is, unexpectedly, better than ever. There's still not a fad in it, and it is still lean, brief, and witty. Now with more attention to aging, more reliance on home testing, and more encouragement for weightlifting, this is still the best overall guide to the how and why of getting fit.

—KK

Fat people who are constantly dieting should worry less about how to lose weight. Instead they should ask themselves, "Why do I gain weight so easily?"

As a person becomes more and more out of shape and the muscles fill up with fat, the arms and waistline become softer and softer. I remember a tall, thin young woman I tested who had never exercised a day in her life. I gripped her arm and said, "Tighten up, Susie."

"Okay!" she said obligingly. I waited a few seconds, but her arm felt as soft as ever.

"Tighten up, Susie," I repeated.

"I am, I am!" she grunted, her face red from the effort.

This woman was so out of shape and her muscles were so soft no amount of flexing made them harder. She looked thin on the outside, but she was fat on the inside.

The underwater immersion test is time-consuming, takes up lots of laboratory space, and is scary for many people, so most testing facilities use less accurate but more convenient methods. Most techniques measure the fat just beneath the skin, on the assumption that the amount of subcutaneous fat increases as total body fat increases. When you consider all the places inside the body where fat can accumulate, such as around the intestines and inside muscles, it's hard to believe that measuring skin fat would reflect total body fat, but we have measured peoples' fat both underwater and with the skin test for years and using our formula, subcutaneous fat measurements are amazingly accurate.

Remember! If you can't exercise exactly by the rules I've given you, just do a lot of it. Quantity can substitute for quality. That's why sports almost always makes people fitter than strict exercise at a health club.

Don't Even Think about Distance

It doesn't matter how far you go. What matters is how many minutes a day you spend trying to change your body into a fit body. Exercise for time, not distance.

### Ultimate Fit or Fat

Covert Bailey  
1999, 170 pages  
\$11  
Houghton Mifflin



Covert Bailey's Four Food Groups of Good Exercise

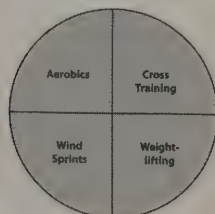

Get a balanced diet of good exercise.



"Before" and "after" snapshots of participants in a contest to see how much they could change their bodies in twelve weeks.

## Body for Life 12 Weeks to Mental and Physical Strength

Okay, you are sold on the basic sanity of Fit or Fat, but what do you actually do today? I mean where do you start? The best answer to that question is Body for Life, which pound for pound has more motivating specifics than anywhere else. The catalyst is a simple bargain: you can change the shape and fit of your body in twelve weeks if you are willing to work reasonably hard with a reasonably flexible plan manageable by most busy people. I figured I could stand almost anything for twelve weeks, if it produced results. Well, it worked for me at least, much better than I expected, and it has apparently worked for many others, judging from the photos and the constant friend-of-a-friend referrals this book produces. Most importantly, once your body reshapes itself (this is not about losing weight), the logic of Body for Life (the same as Fit or Fat) becomes habit.

—KK

### Body for Life 12 Weeks to Mental and Physical Strength

Bill Phillips  
1999, 201 pages  
\$25  
HarperCollins

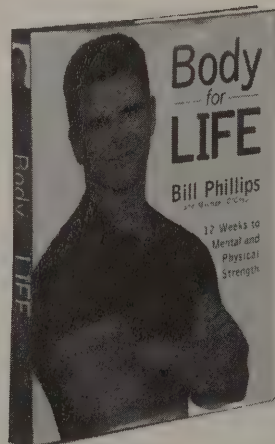

Myth: aerobics is better for shaping up than weight training.

Fact: To transform your physique, you must train with weights.

Myth: Muscles grow while you're working out.

Fact: Muscles grow while you are resting and recuperating.

Myth: Lifting a weight is what stimulates muscle growth.

Fact: Lifting and lowering a weight stimulates muscle growth.

Enough evidence now exists to concretely state that lowering the weight is just as important as lifting it. It's true. It turns out that weight lowering causes much of the muscle-cell damage that stimulates an adaptation. You see, when you lengthen the muscle, which occurs during that eccentric portion of an exercise, you literally tear portions of the muscle fibers, signaling a stage of remodeling, or muscle growth. (You'll know when you've experienced this phenomenon because a day or two after your workout, your muscles will be sore. That's a sign that the "earth has moved.")

When you apply the Intensity Index properly to both your resistance training and aerobic workouts, you'll never hit the ceiling. You'll always move up to higher and higher high points. And that means you'll continually be stimulating your muscles while losing fat. You'll become more metabolically efficient. Your body will burn fat at a significantly elevated rate, even while you're sitting at your desk or driving your car or reading a book...even while you're sleeping.

The 20-Minute Aerobics Solution™

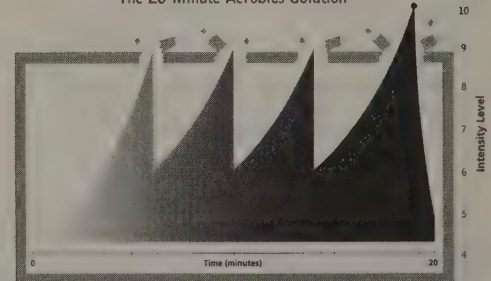

[This graph demonstrates the pattern of strength-building aerobics. To maximize a twenty-minute workout, you must press toward your maximum effort and "break through" your intensity level.]



## Power Bars

The original nutrition bar from Berkeley is still the best. On the mountain, on airplanes, or on a random weary afternoon at work, a Power Bar is the clearest pickup my body answers to. I buy 'em by the case.

—SB

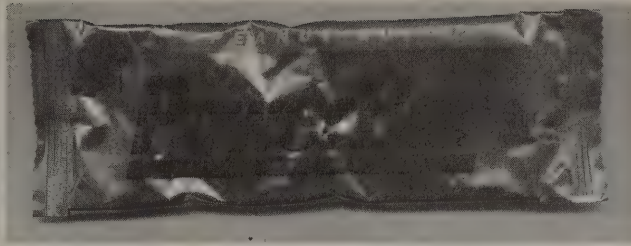

## Power Bars

By the case, Any warehouse store, like Costco

## The Merck Manual of Medical Information Home Edition

Frankly, most medical compendiums for the home suck. The only remotely useful book for lay people has been the Merck Manual, long the standard of information in doctor's hands. But while the Merck Manual contains the kind of detailed and reliable info you really need, it is tough to decipher its jargon and medical logic. That's why this hefty paperback is so fantastic. It has the same intelligent, no-nonsense, unadulterated material, but presented in a much friendlier, easier-to-parse style. And it's cheap. In our family we keep the standard Merck as backup, but most times all we need is the Home Edition.

—KK

### Examination of Vocal Cords

### Examination Findings

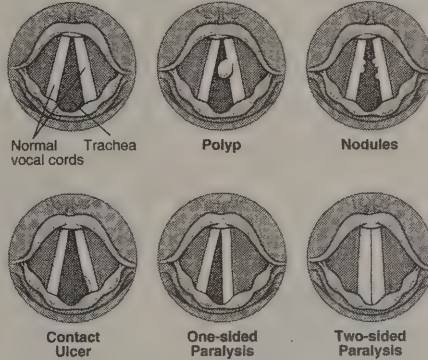

## The Merck Manual of Medical Information

### Home Edition

Robert Berkow, Ed.  
1997, 1,620 pages  
\$8  
Pocket Books

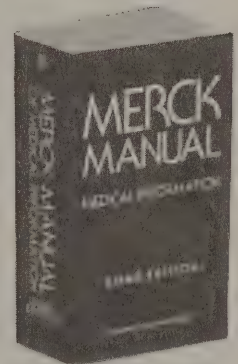

### A Child With Mumps

A child with mumps will likely develop a tender swelling between the ear and the angle of the lower jaw.

### Normal Anatomy Undescended Testis

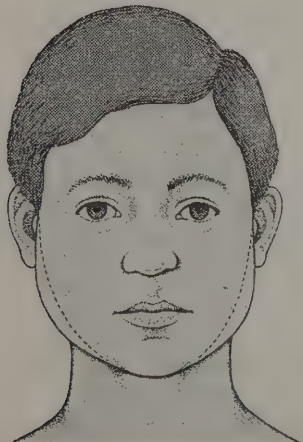
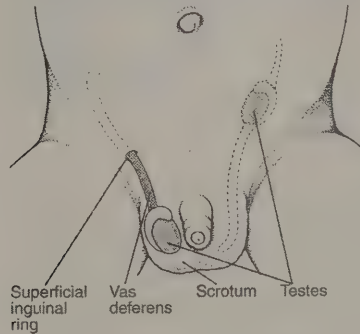

### Bell's Palsy Paralyzes One Side of the Face

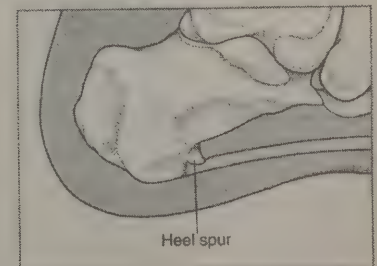
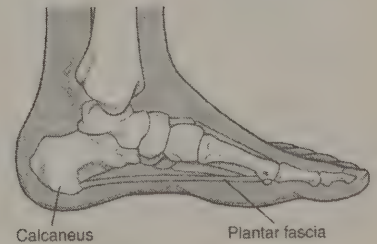





"To the rich, the very rich, and the super rich! Have I left anybody out?"



## The New Yorker Book of Money Cartoons

The weirdness of our obsession with money exceeds the weirdness of our obsession with sex. Money is funny.

—KK

### The New Yorker Book of Money Cartoons

1999, 109 pages  
\$22  
Bloomberg Press

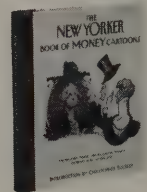

## Die Broke

### A Radical Four-Part Financial Plan

God punishes one generation when it accepts the undiminished wealth of the previous generation. The way to escape perpetuating generational richness is to die broke. But what about college for my kids, or when I'm old, or retired? This book has answers and very specific tactics for the liberation of all from the myth of inheritance.

—KK

You are not a corporation—you are a human being. Your money shouldn't outlive you. You should exit life as you came into it: penniless. Your assets are resources to be used, for your own benefit and for the benefit of those you love. Every dollar that's left in your bank account after you die is a dollar you wasted. Use your resources to help people now when you know they need it, when it will do the most good, rather than hoping they'll be helped when you're dead. The last check you write should be to your undertaker...and it should bounce.

Inheritance is a terribly inefficient way to pass wealth to others.

You need to shift to a more flexible view of work and career, one that abandons the ultimatum of retirement—a false choice between full-time and no time....Similarly you need to shift to a less rigid approach to earned income. No longer can you look at your earned income as continually increasing up until age sixty-five, at which point it will stop entirely. From now on you need to approach earned income as you do unearned income. It may grow, it may be stagnant, or it may decrease, all depending on market conditions and your own choices.

The best metaphor I can think of for today's pursuit of retirement is of a mass of lemmings busily struggling up a steep cliff and then jumping off the cliff into the abyss.

Dying broke means living well.

### Die Broke A Radical Four-Part Financial Plan

Stephen M. Pollan and  
Mark Levine  
1997, 305 pages  
\$14  
HarperBusiness

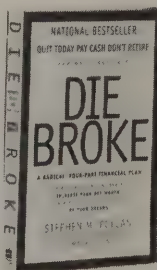

## Fidelity Charitable Gift Fund

The only sane antidote to massive amounts of wealth is massive amounts of philanthropy. But giving is a habit that is best begun before you are loaded (the great philanthropist Carnegie began when he was making a few dollars per week). Indeed, some of the most influential funding in history has been small, but creative, grants.

Creating a personal foundation is a growth industry these days; the most in-demand hire in Silicon Valley is the personal fund manager. You can spend half your fortune creating and maintaining a foundation, or you can do it the easy way. The Fidelity Charitable Gift Fund is a mutual fund run by Fidelity which provides most of the functions an ordinary giver might want from a personal foundation. Best of all, it requires a minimum of "only" \$10,000. Here's how it works.

You deposit your contribution in Fidelity, which invests the amount in a mutual fund pool (you get to choose the level of risk/payback you want for your money, but they choose and run the fund). Whenever you want to make a donation, you tell them, and as long as it is a tax-deductible outfit (it can't be an individual), they send 'em a check.

The main advantages are four:

- 1) The money grows. Like a real foundation, your money is invested, and the returns on those investments are reinvested and further enlarge your fund for giving. Depending on what percentage you disburse each year, the total can accumulate significantly. (Fidelity suggests you give at least 5 percent of your fund each year.)
- 2) You can gift stock (or securities) directly to the fund. The hi-tech boom is awash in highly appreciated stock, which if cashed out would trigger huge capital gains tax for the owners. What many dot-comers do is donate the stock without cashing it. Their Gift Fund account is credited with that high value of the stock at market value, but the giver doesn't have to pay for the huge gains, because those gains are now the gains of a nonprofit fund. The givers receive the normal charitable giving tax deduction for the market value of the stock. You can do the same with ordinary stock investments. Say you were lucky enough to buy twenty shares of Cisco when it was \$10 per share. Say when Cisco hits \$200 per share, you decide you want to do something creative and meaningful with your small fortune of \$4,000. You bestow the Gift Fund with the twenty shares of Cisco, which then credits your philanthropic account with \$4,000. But instead of having to pay a capital gains tax on \$3,800 (\$4,000 minus \$200, your cost), you get a tax deduction on \$4,000. That \$4,000 can then amplify further (see point 1). A common tactic for Gift Fund users is to donate their highest flying, most ridiculously inflated stocks for

maximum philanthropic joy and smallest capital gains pain.

3) It's free. Well, almost free. Fidelity charges the usual industry standard of any mutual fund (less than one percent), but this is far less than hiring a personal fund manager, or even setting up a private foundation yourself.

4) You get to name your foundation anything you want. As futurist Paul Safo says, the Lexus was the status symbol of 90s; the status symbol of the coming decade will be the personal foundation. Having a foundation of your own focuses attention on keeping it full, and encourages discipline in giving it away.

Because accounts within the Gift Fund are so easy to set up they are often used for giving circles. A giving circle is a group of friends or advocates who decide to combine their resources to fund a cause. They create a virtual foundation without the usual expense and work of setting up a bona fide nonprofit (which is needed to receive funds, but not give them) and collectively research and debate who/where/how to fund their mission.

The Gift Fund is so useful for givers of more modest means that it has drawn in about \$2.5 billion dollars, making the collective Fidelity Charitable Gift Fund the third largest public foundation in the US, and the number-one foundation in total amount of money dispensed last year. Of course it is not really one foundation, but 24,000 small foundations, many of them pioneering creative philanthropy. You don't have to fund the opera and hospitals. As an example, here are some donations clients of the Gift Fund recently made:

- Support for a historic preservation speaking tour
- Rebuilding a scout camp destroyed by fire
- Funding for the development of a textile study center at an art museum
- Support for an archeological dig at a national park
- Support for Native American students majoring in science
- Supplying an animal shelter with an examination table and equipment
- Support for a summer theater

My experience with the Gift Fund has been great. It was simple to set up, with a minimum of paperwork, and when it comes time to make a donation, the effort is pretty painless. Having a convenient do-it-yourself vehicle, with tax breaks, and investment upsides, has encouraged our giving.

—KK

### Fidelity Investments Charitable Gift Fund

82 Devonshire Street  
Boston, MA 02109  
800/ 682-4438  
www.charitablegift.org



## A Framework for Understanding Poverty

Poverty is not just a condition of not having enough money. It is a realm of particular rules, emotions, and knowledge that override all other ways of building relationships and making a life. This book was written as a guide and exercise book for middle-class teachers, who often don't connect with their impoverished students—largely because they don't understand the hidden rules of poverty. In the same way, poor children misconnect with school because they don't understand the hidden rules of middle-class life. Ruby Payne, a former teacher and principal who has been a member of all three of the economic cultures of our time (poor, middle-class, and wealthy) compassionately and dispassionately describes the hidden rules and knowledge of each. I think it's useful not just for educators, but for anyone who has to deal with people of different backgrounds. Having read it, I feel a lot more confident about dealing with people as people, not as representatives of their social class.

Especially noteworthy is the "Could you survive?" quiz on page 53. For example, can you keep your clothes from being stolen at the laundromat, or entertain friends with stories? (That's essential knowledge for the world of the poor.) Can you get a library card or use a credit card? (Essential for middle-class life.) Can you ensure loyalty from a household staff, or build a wall of privacy and inaccessibility around you? (Essential knowledge for wealth.) Every class assumes that their knowledge is known by everyone, which is one reason they assume that people in other classes don't "get it." I also appreciate the telling point about upward mobility in America: It's possible for anyone to shift classes, but only at the price of leaving behind your existing personal relationships. One sign of A Framework's value is the way that educators who grew up in poverty, from a variety of ethnic backgrounds, embrace this book.

—Art Kleiner

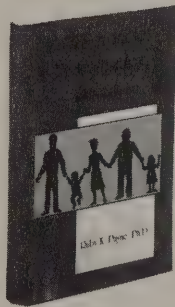

### A Framework for Understanding Poverty

Ruby K. Payne  
1998, 204 pages  
\$22  
Aha! Processing  
Highlands, TX 77562  
800/424-9484  
www.rubypayne-poverty.com

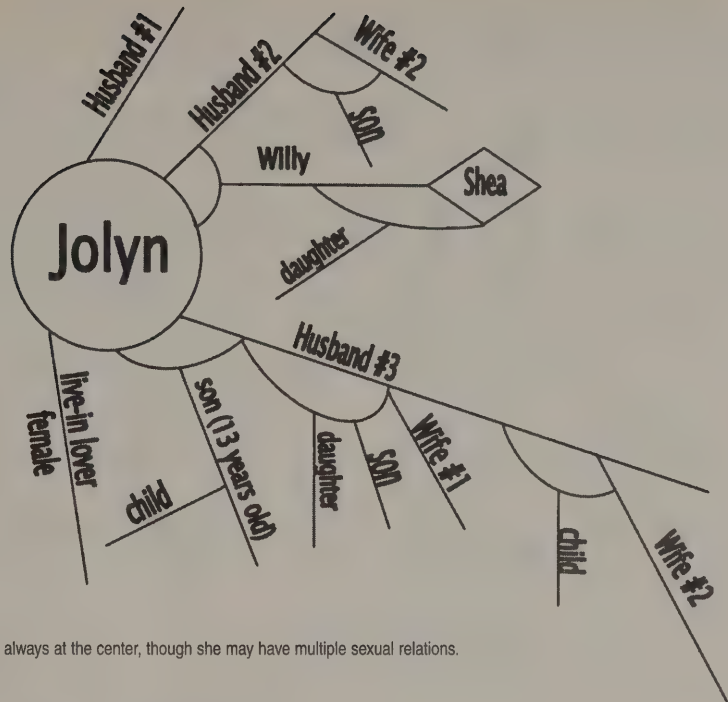

The mother is always at the center, though she may have multiple sexual relations.

## Story Structure



THE FORMAL-REGISTER STORY STRUCTURE STARTS AT THE BEGINNING OF THE STORY AND GOES TO THE END IN A CHRONOLOGICAL OR ACCEPTED NARRATIVE PATTERN. THE MOST IMPORTANT PART OF THE STORY IS THE PLOT.

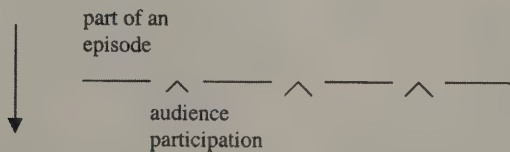

THE CASUAL-REGISTER STORY STRUCTURE BEGINS WITH THE END OF THE STORY FIRST OR THE PART WITH THE GREATEST EMOTIONAL INTENSITY. THE STORY IS TOLD IN VIGNETTES, WITH AUDIENCE PARTICIPATION IN BETWEEN. THE STORY ENDS WITH A COMMENT ABOUT THE CHARACTER AND HIS/HER VALUE. THE MOST IMPORTANT PART OF THE STORY IS THE CHARACTERIZATION.

## Foreign Affairs

The most global of all magazines. This previously rarified academic backwater is now the frontline forum for debating the form of the global village. Bold, brash, and intelligent. There are more Big Ideas per issue than anywhere else.

—KK

### Foreign Affairs

6 issues per year  
\$44 per year, US  
PO Box 420235  
Palm Coast, FL 32142  
800/829-5539

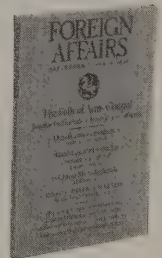

The current American policy is to try to stop proliferation while simultaneously continuing to hold on to its nuclear arsenal indefinitely. But these objectives are contradictory. The current policy is a way of avoiding choice—a policy without traction in the world as it really is. —Jonathan Schell, "The Folly of Arms Control"

Twenty-first-century America is one of the most litigious societies the world has ever known. Civil lawsuits in American courts are used to resolve an ever-expanding list of conflicts. But new forms of litigation can have powerful and wide-ranging consequences, both intended and unforeseen. This is especially obvious in one area long thought outside the power of domestic courts: foreign policy. Increasing numbers of individuals, including torture and terrorism victims, Holocaust survivors, and denizens of the dwindling Amazon rain forest, are now using lawsuits to defend their rights under international law. —Anne-Marie



## Ultraviolet Lighting

Also referred to as black light, long-wave ultraviolet light is used for leak detection, magnetic-particle and dye-penetrant inspection, quality control, UV curing, security control, document examination, and more. Light intensity rates the strength of the radiation and is measured in microwatts/cm<sup>2</sup> (µW/cm<sup>2</sup>). The higher the intensity rating, the stronger the ultraviolet light.

### About Long-Wave Ultraviolet Light

**High-Intensity Spot-Beam UV Lights**

Long-wave ultraviolet light is emitted from a light on a specific area. Light intensity rates the strength of the radiation and is measured in microwatts/cm<sup>2</sup> (µW/cm<sup>2</sup>). The higher the intensity rating, the stronger the ultraviolet light.

Long-wave ultraviolet light is emitted from a light on a specific area. Light intensity rates the strength of the radiation and is measured in microwatts/cm<sup>2</sup> (µW/cm<sup>2</sup>). The higher the intensity rating, the stronger the ultraviolet light.

**Rechargeable Broad-Beam UV Light**

This handy light has an internal, rechargeable lead-acid battery. When the light is not in use, it will remain on a low-power standby mode for up to 48 hours. To recharge, use the included power supply. Recharge time is 12 hours. Light intensity rates the strength of the radiation and is measured in microwatts/cm<sup>2</sup> (µW/cm<sup>2</sup>). The higher the intensity rating, the stronger the ultraviolet light.

**Broad-Beam UV Lights**

These lights have a long, narrow beam that sheds light over a wide area. Light intensity rates the strength of the radiation and is measured in microwatts/cm<sup>2</sup> (µW/cm<sup>2</sup>). The higher the intensity rating, the stronger the ultraviolet light.

**Portable Spot Light**

This light is designed for use in confined spaces. Light intensity rates the strength of the radiation and is measured in microwatts/cm<sup>2</sup> (µW/cm<sup>2</sup>). The higher the intensity rating, the stronger the ultraviolet light.

### Digital UV Intensity Meter

Measure the intensity of your black light in specific areas. It has a built-in LCD display and a digital readout. Light intensity rates the strength of the radiation and is measured in microwatts/cm<sup>2</sup> (µW/cm<sup>2</sup>). The higher the intensity rating, the stronger the ultraviolet light.

**UV Detection Powder**

Sprinkle powder on any article that may be subject to tampering or theft. When touched, compound reacts to hands and clothing and will fluoresce under UV light. Light intensity rates the strength of the radiation and is measured in microwatts/cm<sup>2</sup> (µW/cm<sup>2</sup>). The higher the intensity rating, the stronger the ultraviolet light.

**Magnetic-Powder Dispenser**

The best way to evenly apply magnetic powder for leak detection. Dispenser has a magnetic base and a handle. Light intensity rates the strength of the radiation and is measured in microwatts/cm<sup>2</sup> (µW/cm<sup>2</sup>). The higher the intensity rating, the stronger the ultraviolet light.

## McMaster-Carr Online Catalog

The best way to describe McMaster is to say that they carry everything you need to build anything. Items that you could normally only order through factory distributors, or materials that could only be ordered in large quantities, are easily available in any size and quantity, no matter how small. (No minimum order, either!) Their prices are excellent and they tend to only carry good merchandise. Amazingly, when I order stuff at 5:30 P.M., it arrives the next morning with their normal shipping. Their catalog has long been difficult to get because you had to be a reasonably sized business with a Dun and Bradstreet number and established credit to have them mail it to you. But now that they have added an online service, everyone can easily order from them with a credit card.

—Alexander Rose

## McMaster-Carr Online Catalog

www.mcmaster.com

## eBay, Tinker's Paradise

I don't collect things. But I use eBay all the time to find stuff for building projects. I buy batteries, motors, and remote control gear for my robotic projects. For a flamethrowing project we bought all our Fire Proximity and Entry suits (for walking into fire) on eBay (these \$2,000 suits go for a few hundred dollars). I even find a lot of new stuff there. I bought my brand-new generator there for about \$300 less than the cheapest online price. I can get international coded DVDs that can be played on any player, not just ones with the US code on them. I use eBay to buy obscure machine tools. For instance, for one project we bought a Mitutoyo 0-5 foot caliper that measures to .001" for \$250; these normally sell for about \$3,000.

—Alexander Rose

## eBay

www.ebay.com

## Pocket Ref

People who make things keep one of these little books in their truck, one in their tool box, and one in their office. Its tiny pages are crammed with dense tables, charts, lists, codes, conversion formulas—more than 500 pages of numbers, yet it fits into a real pocket. What is the friction rate of water in a one inch pipe? What's cubic feet per second in liters per minute? The country code for Turkey? The voltage drop of number 12 wire over 100 feet? The shear strength of Eastern White Pine? The insulation value of carpeting? You get the idea; it has the numbers for everything, and 95 percent of them found nowhere else.

—KK

### Pocket Ref

Thomas J. Glover  
1998 (2nd edition), 542 pages  
\$10  
Sequoia Publishing  
Littleton, CO 80162  
303/972-4167  
www.pocketref.com

## Bent-Nose & Hemostat Pliers

### Bent-Nose Pliers

1 **Bent Long-Nose Pliers**—Great for twisting and looping fine wire, these pliers have a bent nose to reach around obstructions. Made of forged steel with a polished finish, they have serrated jaws and cushion-grip handles.

O'all	Jaw Bend	Jaw Lg.	Tip Thick. (A)	Each
4 1/2"	45°	7/8"	3/32"	\$336A39 • \$15.11
6"	60°	1"	3/32"	\$632A14 • 17.04
6 1/4"	45°	2 1/8"	3/32"	\$383A16 • 23.81
8"	70°	2 3/8"	3/32"	\$632A18 • 29.96
11 3/8"	45°	2 3/4"	3/32"	\$337A43 • 23.25

• Jaws are smooth. Δ Has a side cutter.

### Clamping Pliers

These lightweight pliers have a bent nose for reaching around corners and a spring-action handle that clamps jaws down on parts. Just squeeze the handles to open the jaws; release the handles and the jaws snap closed. Made of hardened steel, pliers have serrated jaws and cushion-grip handles.

O'all	Jaw Lg.	Tip Thick. (A)	Each
6"	3"	1/4"	\$295A41 • \$9.10

### 400 Series Stainless Steel Hemostat Pliers

Straight Jaw with Cushion-Grip Handles

O'all	Jaw Lg.	Tip Thick. (A)	Each
6"	3"	1/4"	\$295A41 • \$9.10

30° Bend Jaw with Plain Handles

O'all	Jaw Lg.	Tip Thick. (A)	Each
6"	3"	1/4"	\$295A41 • \$9.10

### Static-Dispersive (ESD-Safe) Bent Long Handle-Nose Pliers

Special cushion grips dissipate electrostatic charges to protect sensitive electronics components. With long narrow jaws and a bent nose, pliers are great for reaching over and between closely spaced components. Jaws are serrated. Pliers are made of forged steel with a polished finish and have a coil spring return in the handle.

O'all	Jaw Bend	Jaw Lg.	Tip Thick. (A)	Each
5"	60°	1 1/8"	1/16"	\$336A42 • \$16.11
6"	75°	1 1/8"	1/16"	\$337A41 • 13.03

### Insulated Bent Long-Nose Pliers with Side Cutter

Designed especially for working on powdered switchboards, these pliers have insulated handles to help protect you from shock and finger guards to help prevent contact with the jaws. Made of forged, chrome-plated steel with a polished finish, pliers have serrated jaws and a built-in cutter for cutting soft and hard wire. Comply with IEC 900 and ASTM F1505-94 standards. Maximum recommended use is 1000 volts.

O'all	Jaw Bend	Jaw Lg.	Tip Thick. (A)	Each
8"	45°	2 3/8"	3/16"	\$454A81 • \$43.88
8"	90°	2 3/8"	3/16"	\$454A82 • 45.91

### Round-Nose Pliers

Also known as jewelers' pliers, these pliers are used to form and loop fine wire. They have round, pointed, smooth jaws.

**Standard**—Made of forged steel with polished finish. Handles have cushion grips.

**Insulated**—Made of oil-hardened, chrome-plated forged steel with a polished finish. Handles are insulated and have finger guards to help prevent contact with the jaws. Comply with IEC 900 and ASTM F1505-94 standards. Maximum recommended use is 1000 volts.

O'all	Jaw Bend	Jaw Lg.	Tip Thick. (A)	Each
Standard	47 1/2°	4 1/8"	3/16"	\$779A8 • \$15.58
Standard	60°	1 1/8"	1/16"	\$779A8 • 15.75
Insulated	60°	1 1/8"	1/16"	\$373A51 • 29.71

### Precision Micro-Pliers

Use these micro-pliers when precision is a priority and space is limited. Ideal for working under a microscope or in any tight, confined area. Pliers are self-closing. Made of Type 440 stainless steel. They're suitable for working in a clean environment. Overall length is 3". Jaw length is 1/4".

O'all	Jaw Capacity	Jaw Lg.	Each
3"	1 1/4"	3/4"	\$737A42 • \$20.82

	Each
1 Standard Needle Nose	\$261A11 • \$27.78
2 Round Nose	\$281A12 • 27.78
3 Flat Nose	\$281A13 • 27.78
4 45° Bent Nose	\$261A14 • 27.78

### WEIR DISCHARGE TABLES

Height of water flow H

Head Inches	GPM for Width of Weir in Feet	gpm/foot over 5 feet wide
1	35	107
1.5	64	197
2	98	302
2.5	136	421
3	178	552
4	269	845
5	369	1174
6	476	1534
7	589	1922
8	708	2335
9	834	2769
10	966	3225
12	1268	4189
14	1608	5501
16	2000	7181

Based on the Francis formula:  
Q = 3.33 (W - 0.2H) H<sup>1.5</sup> Where H=height in feet, W=width in feet and distance "A" should be at least 3 H.

**Water 421**

**Ceramic Capacitor**

**Disc Capacitor**

White - EIA Code  
Black - Military Code  
Color - Old EIA

Classification

Mica Capacitor



## Don Lancaster, Open Research Guru

Don Lancaster is a prolific technical hacker, whose publications have been covered by Whole Earth for decades. His Incredible Secret Money Making Machine is a Whole Earth Catalog regular, and still the best book on how to run a small-time technical or craft business. Don was one of the earliest "home computer" hackers. He has written how-to-mess-with-stuff books on chips, laser printers, and scanners. He specializes in hacking—making ordinary things do things their inventors had not thought of. His how-to advice has always been leading edge, technically clever, and as much as possible, free. For years Don has been running one of the most unusual research outfits going. As he uncovers cool hardware, amazing knowledge, or novel techniques, he posts what he finds immediately. Don conducts open research. He has no technical secrets; in fact his life is propelled by the joy of broadcasting technical secrets. (See his Case Against Patents, page 44) The Web amplifies his love for open source research. You can find remarkably geeky tracts on all manner of technical subjects on his dense Web site (check the "What's New" box). Because Don is one of the best sources I know of for locating hard-to-find sources and odd tools, I asked Don to summarize his latest passions.

—KK

I am presently webmaster of my GURU'S LAIR at [www.tinaja.com](http://www.tinaja.com). My goals here are to have an eclectic mix of unique technical content, a complete, fully searchable reprint archive, and an annotated-link gateway to a wide range of unusual web resources. As always, I go on the assumption that if I happen to find something interesting or exciting or unique, then others might do so as well.

## Sewing Awl



One of the world's oldest tools, but one that is often overlooked. This is a heavy-duty needle with its eye at the working end, mounted in a handle. For mending leather, shoes, bags, sewing canvas, or stitching heavy materials, there's no better tool. I don't use mine often, but it has a place in the essential toolbox. Your local Ace Hardware sells a kit with tool, extra needles, and waxed thread.

—KK

## The Speedy Stitcher Sewing Awl Kit

\$16  
Stewart Mfg. Co.  
PO Box 643  
Northboro, MA 01532

Or Ace Hardware

A few of my Guru's Lair library pages now include:

**MAGIC SINEWAVES** - A brand new method of achieving super energy efficiency in power electronics. I have ten years of my life tied up in developing this.

**PIC MICROPROCESSORS** - Several library pages include dozens of tutorial and a definitive collection of many hundreds of useful links and resources.

**HYDROGEN ENERGY** - Hydrogen is only an inefficient and rather wasteful energy carrier. I attempt to strip away the wide-eyed fantasies and leave you with real-world tutorials, books, and links to genuinely useful and promising emerging alternate energy resources.

**POSTSCRIPT AND AROBAT PDF** - I'm very big on PostScript as a general purpose computing language. Extensive support and highly detailed tutorials and utilities can be found on these pages.

**TECH MUSINGS** - Has multi topic mini-tutorials on a wide range of electronic, energy, and computer topics. Subjects include video techniques; a definitive page on cubic (Bezier) splines; advanced math techniques; navigation resources; unmerciful pseudoscience bashing; Santa Claus machines (aka rapid prototyping); wavelets; and, of course, tinaja questing.

## Hiring Smart!

### How to Predict Winners and Losers in the Incredibly Expensive People-Reading Game

*Hire smart, your company wins; hire dumb, you die. People are the scare resource in the new economy, but no one teaches employees how to hire people. Successful fast-growing companies have caught on. They now hire people who are good at hiring others. Between these book covers is a million dollars' worth of hiring advice, the best anywhere. If you are in business, ignore at your peril.*

—KK

## Hiring Smart!

**How to Predict Winners and Losers in the Incredibly Expensive People-Reading Game**  
Pierre Mornell  
1998, 226 pages  
\$25  
Ten Speed Press

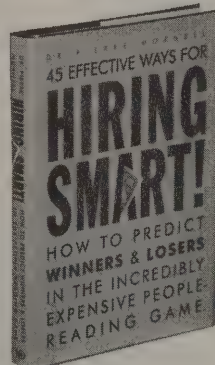

You can't spend too much time or effort on "hiring smart." The alternative is to manage tough, which is much more time consuming.

The best predictor of future behavior is past behavior.

**Strategy No.3:** Give an assignment before the interview. Ask the candidate to visit one of your stores, plants, campuses, offices, or Web pages before the interview. Then ask for the candidate's observations.

**Strategy No.5:** Read resumes in teams if possible. It's helpful—and faster—to read the top candidates' resumes in teams of three to five people. Teams that work well together are more accurate and insightful about potential employees than individuals are.

**Strategy No.6:** Cast the widest net possible. Microsoft

**BLATANT OPPORTUNIST** - Unique tutorials and insider secrets for the home business and small scale tech startups. Coverage includes webmastering, product development, and emerging tech opportunities.

**RESOURCE BIN** - A complete archive of my earlier Nuts & Volts print columns on a wide range of technical resources, such as flutterwumper robotics.

**PATENTS** - Attempts to shatter the outrageously "not even wrong" myths surrounding patents and patenting. Provides thoroughly tested and working real world alternatives.

**INFOPACKS** - This is my very low cost "cash and carry" service that gets you quick answers in a less formal manner than a full blown consulting program. It is particularly strong in pinning down resources and evaluating fundamental concepts.

Finally, my **INCREDIBLE SECRET MONEY MACHINE** is undergoing a major revision and rewrite at the present time.

—Don Lancaster

The Guru's Lair, [www.tinaja.com](http://www.tinaja.com), 520/428-4073  
3860 West First Street, Thatcher, AZ 85552

assumes that the best candidates are not looking for jobs. In fact, candidates who approach Microsoft are actually less attractive to the company.

**Strategy No.13:** Ask all your questions at once. That's right. Put all your initial questions on the table up front. This strategy accomplishes three things. First, in a manner of speaking, you pass the baton. You've asked the questions, now the candidate must respond. Performance depends upon the candidate, not selling yourself and the organization. Second, more importantly, this strategy directly confronts the most common problem in interviewing: not listening, and talking too much...Third, this technique forces you to listen. If there's one practical tip you should try in your next interview, I suggest this one. Asking all your questions at once, and following up later in the interview, allows you to settle back and watch a candidate's behavior as well as listen to his or her words.

**Strategy No. 15:** Assign a mini-project to finalists. Three quarters of the way through the interview, give the candidate a task to perform. Not only does this demonstrate the candidate's behavior—it also breaks up the monotony of most interviews.

**Strategy No. 32:** Ask the references to call you back. Here is the simplest, most effective reference check that I know. It's also fast and legal. Call references at what you assume will be their lunchtime—you want to reach an assistant or voice mail. If it's voice mail, leave a simple message. If it's an assistant, be sure that he or she understands the last sentence of your message. You say: "John (or Jane) Jones is a candidate for (the position) in our company. Your name has been given as a reference. Please call me back if the candidate was outstanding."

The results are both immediate and revealing. If the candidate is outstanding or excellent, I guarantee that eight out of ten people will respond quickly and want to help....However, if only two or three of the references selected by the candidate return your call, this message is also loud and clear. And yet:

No derogatory information has been shared.

No libelous statements have been made.  
No confidence or laws have been broken.

**Strategy No. 39:** Invest in people, not ideas.

Unfortunately, an employer's ability to hear bad news about a potential employee is inversely proportional to the time spent courting that employee.



## Rembrandts in the Attic Unlocking the Hidden Value of Patents

*I've changed my mind about patents because of this book. I was involved with Wired magazine when Wired invented the click-through ad banner on the Web. Had any of us known this innovation was patentable (it was), I don't think we would have done so, even though the authors of this book calculate this patent could have been worth \$20 million per year. But as in any arms race, had we invented it now we would have been forced to patent it just so another company would not.*

*I don't think patents give you much protection if you are the little guy, and I think the US patent system needs a top-to-bottom overhaul. But if you are running a company, my advice—and this is where I changed my mind—would be to behave as if you are patenting everything. The discipline of patenting emphasizes the value of ideas, and the skills to manage, assess, and develop intangibles, which is ordinarily difficult to do. Until the laws are changed, run your company as if any good idea was potentially patentable, even if you don't follow through, except occasionally. (See a radical alternative view below.)*

*Whether you decide to play this game, or change it, the practical art and science of mining, leveraging, swapping, planning, and strategically using patents are covered here concisely and with the clarity of an alarm bell.*

—KK

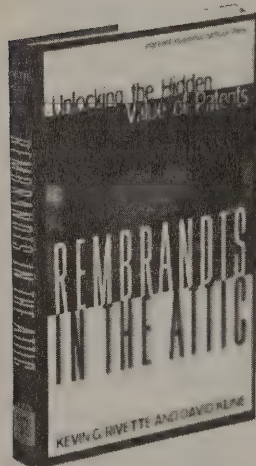

## Rembrandts in the Attic Unlocking the Hidden Value of Patents

Kevin G. Rivette and David Kline  
2000, 240 pp.  
\$27  
Harvard Business School Press

"With everything moving at Web time now," he asks, "who the hell has time to do a patent search?" Perhaps a better question to ask is, Who has the time (or the million-plus dollars) it takes to defend against a patent suit? And who can devote a year or more of R&D effort on a product only to have to abandon it later because of an infringement problem that could easily have been spotted and designed around early in the process? In any event, allowing patenting strategy to be defined solely by the life span of the product itself is a very shortsighted approach.

Perhaps the best way to grasp the concept of bracketing is to imagine that your competitor has invented a new high-intensity light and has patented the filament. But, as it turns out, the filament requires a more durable glass bulb and socket housing to absorb the added heat, as well as more heat-resistant shade construction and electrical connectors. Your competitor may have patented the filament, but if you patent everything else, then the competitor is locked out of much of the market. That's the essence of bracketing.

[Thoman] saw first-hand how an aggressive intellectual property effort boosted patent licensing royalties a phenomenal 3,300 percent, from \$30 million in

1990 to \$1 billion annually today. This \$1 billion per year, it should be noted, is largely free cash flow... To match that sort of net revenue stream, IBM would probably have to sell \$20 billion worth of additional products each year....

A 1997 study by Coopers & Lybrand (since merged with Price Waterhouse) found that two-thirds of the \$7 trillion market value of all publicly traded U.S. companies is not even shown on their balance sheets because it lies not in their real estate or plant and equipment but in their intangible assets such as intellectual property.

Accelerating technology is plunging the world of ideas into a runaway patent arms race. More ideas are being created, and more emphasis and wealth placed on ownership of those ideas. At the same time courts are expanding what can be patented. This forces many companies and universities into a pure defensive maneuver to patent ideas they would not have otherwise. And that in turn forces others to do the same.

Our current legal containers for intellectual property—patents and copyrights—are not adequate for this rush, yet never before has it been so essential that our ideas be anchored in the law. Until our intellectual property laws are updated, this book makes it utterly clear that executives should be sure they are patenting, or at least assessing, every idea their companies have.

FIGURE 3-1 DOW CHEMICAL IP AUDIT MAP

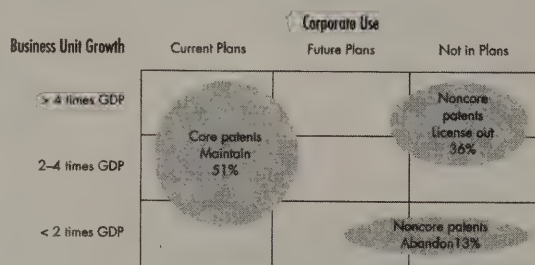
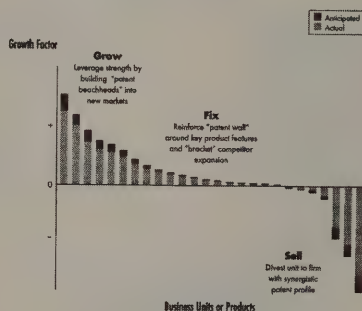

FIGURE 3-2 USING PATENT STRATEGY IN THE GROW-FIX-SELL TRIAGE



## Case Against Patents

*On the other hand, I'm convinced by Don Lancaster's (and others') arguments that patents make no sense for a small-time inventor or technical genius. Patents guarantee you nothing but the right to fight for your idea. Fighting takes a full apparatus, lots of time, negotiating assets, lawyer fees, and emotional surplus. The same results from fighting (ineffectually 99 percent of the time) can be had by moving fast and staying nimble. Patents are a corporate game and should be avoided by anyone trying to work outside of that framework. Here's a lot of encouragement and support from a master non-patent inventor.*

—KK

## Case Against Patents

Don Lancaster  
\$28.50 from  
Synergetics Press  
3860 West Street, Box 809, Thatcher AZ, 85552  
520/428-4073 www.tinaja.com

## High Tech Start Up

*You have is a brilliant idea. But a high tech company to make that idea real is an incredibly complex machine to launch. What you really want is someone who has done this before, someone who can tell you how the bankers really make their money, what dilution means, how to quit your current job ethically, and what you should expect at each stage of "capital development." What you need is John Nesheim, the guru of high tech startups. He's been involved with Silicon Valley entrepreneurs for decades and has seen everything. Despite being an engineer, he correctly places great emphasis on the emotional costs (to you) at every stage. This book is the best; it doesn't hide the nasty side, and it is explicit in an engineer's way about what you have to do. It's worth its weight in stocks.*

—KK

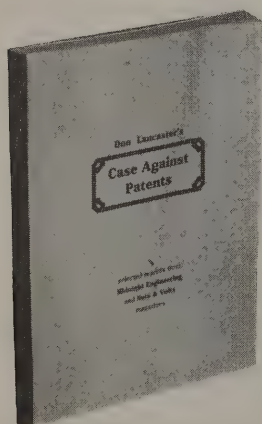



## The Innovator's Dilemma

Although published over three years ago with little notice, this book is just now reaching bestseller status by being recommended on the front lines, manager-to-manager, friend-of-a-friend. It's scary radical. What it proposes is no less than a usable theory of innovation. My bet is that it takes its place next to Thomas Kuhn's *The Structure of Scientific Revolutions*.

According to Christensen, the dilemma of innovation is not that it is rare. Everybody is doing it. The dilemma is that by aggressively innovating to please your current customers you get stuck in success. Yet by chasing the totally new, you go bankrupt for lack of big-time customers. What to do?

Christensen's solution to the dilemma can be summed up in two sentences: Killer technologies start out making sense only in niche or outlying markets. Therefore match the size of the organization to the size of the market.

In my experience, all the buzz-buzz about innovation usually lacks substance. This book feels like a stainless steel carving knife, ready for action.

—KK

## The Innovator's Dilemma

When New Technologies Cause Great Firms to Fail

Clayton Christensen

1997, 225 pages

\$27.50

Harvard Business School Press

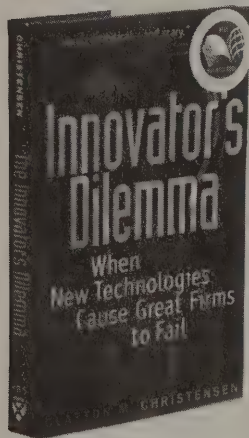

The research reported in this book...shows that in the cases of well-managed firms... good management was the most powerful reason they failed to stay atop their industries. Precisely *because* these firms listened to their customers, invested aggressively in new technologies that would provide their customers more and better products of the sort they wanted, and because they carefully studied market trends and systematically allocated investment capital to innovations that promised the best returns, they lost their positions of leadership.

Occasionally, however, disruptive technologies emerge: technologies that result in worse product performance, at least in the near-term... Generally disruptive technologies underperform established products in mainstream markets. But they have other features that a few fringe (and generally new) customers value.

By and large, a disruptive technology is initially embraced by the least profitable customers in a market.

But while a \$40 million company needs to find just \$8 million in revenues to grow at 20 percent in the subsequent year, a \$4 billion company needs to find

\$800 million in new sales. No new markets are that large. As a consequence, the larger and more successful an organization becomes, the weaker the argument that emerging markets can remain useful engines for growth.

It was as if the leading firms were held captive by their customers, enabling attacking entrant firms to topple the incumbent industry leaders each time a disruptive technology emerged.

The [non-hydraulic excavator manufacturers] did not fail because they lacked information about hydraulics or how to use it; indeed the best of them used it as soon as it could help their customers. They did not fail because management was sleepy or arrogant. They failed because hydraulics didn't make sense—until too late.

Not only are the market applications for disruptive technologies *unknown* at the time of their development, they are *unknowable*. The strategies and plans that managers formulate for confronting disruptive technological change, therefore, should be plans for learning and discovery rather than plans for execution.

Figure 8.4 Managing Changes in the Basis of Competition

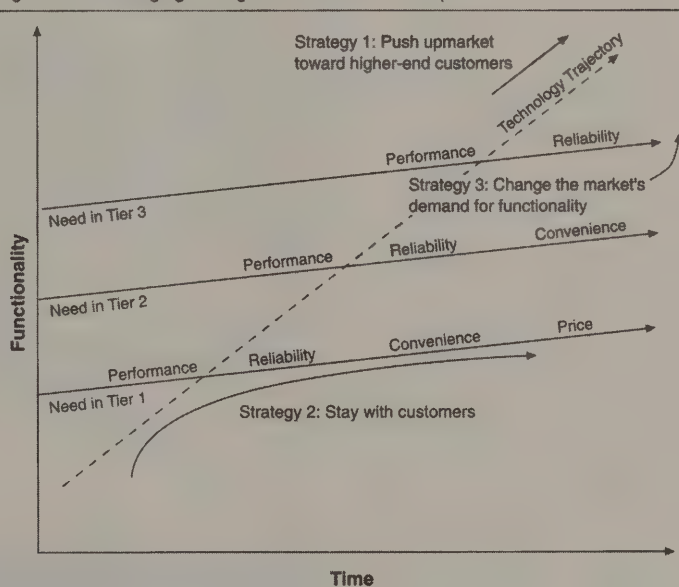

The entrepreneur must realize that the process of raising venture capital never ends. From the first to the last of the fourteen stages of the venture capital formation process... the CEO is continuously occupied with problems of how to raise the needed capital. Experienced start-up staff members of both successful and unsuccessful companies said the same thing: "You never have enough money, things always take twice as long to do as you think, and there is never enough time to stop raising capital while you focus on running the company."

Founder CEOs seldom last as employees for more than three years. This is universally lamented by all parties, including the VCs. We will discuss the reasons and cures later in this book. Silicon Valley psychologists report that few founders make it to the IPO without personal emotional trauma.

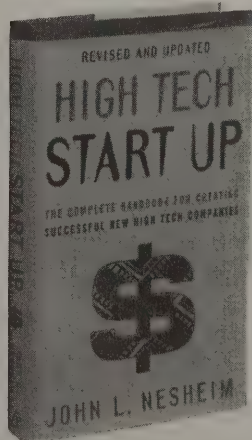

Get in touch with yourself. That was repeated by many of the people we spoke with. Decide what motivates you: joy of work, love of wealth, the satisfaction of getting further than anyone expected, and so on. And decide what failure means to you, as a person, as a company leader.

## High Tech Start Up

The Complete Handbook for Creating Successful New High Tech Companies

John L. Nesheim

2000, 342 pages

\$50

The Free Press



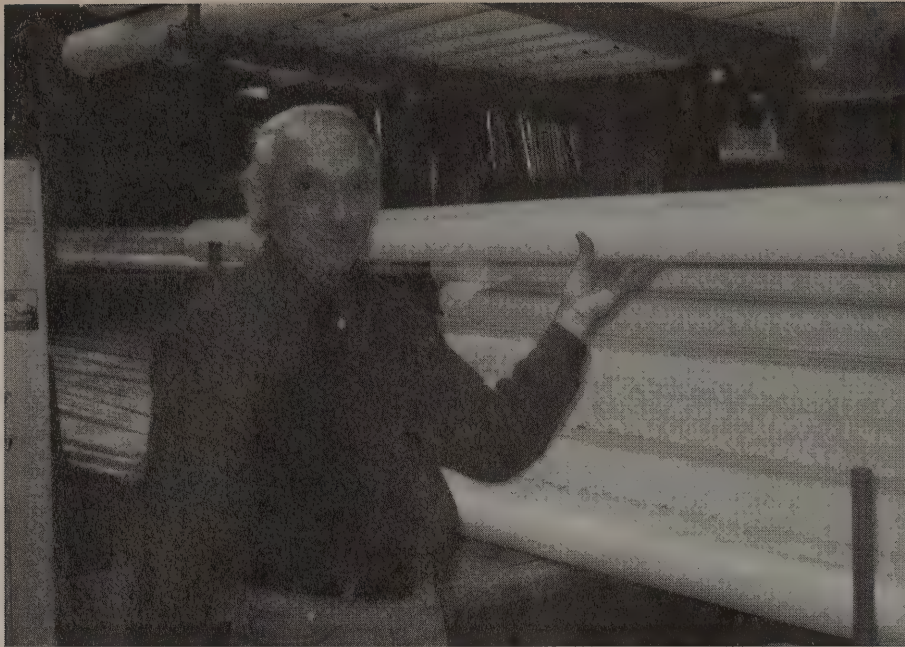

Hey, these PVC pipes would make great pontoons for a rowing boat if you plugged up the ends!

# Cruising Home Depot

*One of the most rewarding field trips I ever took was a day spent with J. Baldwin at a Big4 Rental outfit. We toured the premises and JB discoursed on the amazing things these machines would do for you if you gave them your credit card. I spend a lot my time these days trolling the aisles of our local Home Depot on weekends looking for whatchamacallits—some part or thing I hope will accomplish a task at hand. But I don't have a good lay of the land. Recently I asked JB if he would accompany me on a cruise through the ramparts of Home Depot, searching for new cool goodies, or overlooked and underappreciated old ones. Home Depots are not the best hardware stores in the world, but they are ubiquitous and well stocked. I've given the store's SKU for items we mentioned, which can be useful in tracking them down, in person or online ([www.homedepot.com](http://www.homedepot.com)).*

—KK

## Aluminum Dust Pan

Made from recycled scrap aluminum, this tool is big, superlight, and has a superwide throat for garage-sized messes.

242-815  
\$9.98

## Touch-n-Foam

Liquid nastiness that expands into insulating foam. One can is enough for filling around a door, say, or a couple of windows (depending on crack dimensions).

251-456  
\$4.47

## Black Cable Ties

Immensely handy any time you need to tie or bundle something tightly. Only the black ones, UV rated, will survive (but not forever) in the sun. Longer ones can be cut shorter.

540-831  
\$19.94

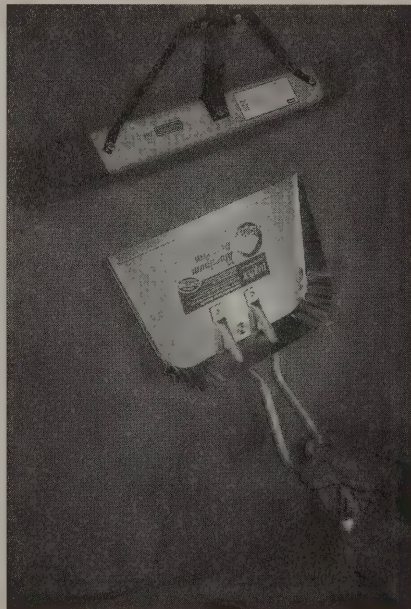

## ScotchKote

Paint-on electrical insulation. Covers splices or exposed wires more thoroughly than electrical tape or shrink wrap; legal and up to code.

129-132  
\$13.75

## Evercoat Two-Part Foam

Mix two liquids and they foam up to fill any and all spaces. Fills, insulates, and soundproofs. Warning: it will stick to everything, including you. Yields about 2 cubic feet per quart.

134-941  
\$37.97

## Evercoat Casting Resin

Use to make exact duplicates of small parts, or tiny figures.

134-965  
\$15.95

## Zinsser BIN Primer Sealer

The only paint that will completely smother graffiti, markers, or stains. Covers anything, never fails. Try it over Masonite as an art paint surface.

164-364  
\$21.97

## Electric Air-less Spray Painter

Sprays all paint, no air. Uses little paint, with little overlap, great control, and doesn't fill the air with drifting paint mist. Cleans easily. You can rent 'em, too. The Wagner 305E is a good model.

579-766  
\$79

## Trim Roller

These itty-bitty paint rollers are just perfect for touchups.

431-621  
\$1.97

## Roller Cover Keeper

Keeps a paint roller wet if you're going to use it again soon.

687-547  
\$1.97

## Jasco Stop-Slip Floor Paint

The sand-like substance in this paint provides a rough, grippable surface even when wet.

384-880  
\$8.91

## Long-Mask (Blue) Masking Tape

One day of sunlight on masking tape will cause it to adhere permanently to whatever it was stuck too; that can get tiresome fast. Blue Masking Tape doesn't have that problem. It's a lot more expensive, but use it when the tape will be there for a while.

958-999  
\$3.45

## 3M Safe-Release Masking Tape

Extra-low adhesion. The stuff to use on wallpaper or freshly applied paint. Also "sunlight stable" so it won't stick permanently in the sun.

958-980  
\$4.28



### Foil Tape

Duct tape in the sun will self-destruct; use this foil tape instead.

915-276  
\$11.95

### Red Duct Tape

Duct tape that actually sticks to stucco and cement, assuming it's been dedusted.

407-158  
\$3.95

### Cotton Cord

Old-fashioned sash cord intended for dangling window weights, but very useful for tie-downs. Hard to find sometimes, but superior in many ways to the plastic stuff because it doesn't slip out of knots as easily.

140-260  
\$1.79

### Refletrix Solar Shield

A radiant heat mirror plus a bit of insulation. Pretty good when you need something for a very thin space, like say in a mini-van roof. It won't withstand direct exposure to the sun.

132-923  
\$39.83

### Flame Protector

A non-asbestos flexible heat shield (the size and thickness of a place mat) that you slip behind or underneath any job that requires a flame, such as when using a propane torch for soldering copper plumbing under the house.

411-396  
\$14.92

### Gutter Scoop

For cleaning out gloppy gutters. Perfectly shaped for the job. Cheap.

978-967  
\$2.92

### Extra-Heat

Nifty device that reclaims heat from your clothes dryer vent for heating the room in cold weather.

146-242  
\$5.97

### DeWALT Magnetic Drive Guide

Keep one of these gadgets on your drill all the time. Makes starting a screw idiot-proof. Solves the problem of no extra hands to hold the screw.

127-549  
\$4.86

### Mini Vise-Grips

For holding things your fingers can't. You'll be surprised how often you'll use them.

308-269  
\$12.46

### Quick Grip Micro Bar Clamp

You can't have too many clamps. These tiny ones are strong and versatile.

206-074  
\$8.94

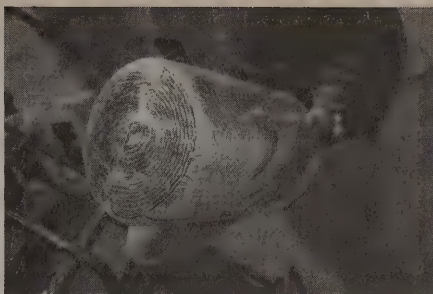

Refletrix Solar Shield



Ratchet Tie-Down



Quick Grip Micro Clamp, Trim Roller, Mini Vise-Grips

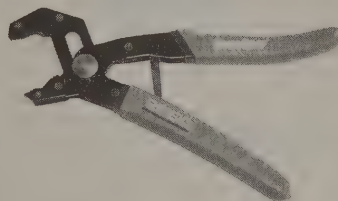

Ridgid RoboGrips



Zircon iSensor Stud Finder



Grommet Kit

### Ridgid Pipe Cutters

The only brand to get. Others will break, particularly if you leverage their handles with "cheater pipes."

747-655  
\$43.97

### Ridgid RoboGrip Pliers

These pliers automatically adjust their jaw size for an extremely tight grip even when you can't see the thing being tightened.

616-537  
\$16.97

### Ratchet Tie-Down

Really the only way to tie things securely on a car roof, or secure large objects, is with this web of heavy fabric. Be sure to get the kind that has a ratchet to tighten it. Hand pulling doesn't get it tight enough.

241-688  
\$8.47

### Zircon iSensor Stud Finder

Interior wall studs are hard to find, and essential for some things, like bookshelves. These once-expensive gizmos are now affordable and work much better than earlier models. Some versions will find wires and pipes, too.

404-233  
\$12.94

### Industrial Strength Velcro

Two-inch wide rolls. Very tenacious stuff. Great for sailboats, inside vehicles, shops. Also comes in a black version which the sun doesn't weaken as quickly.

847-062  
\$26.35

### Grommet Kit.

Put the tarp grommet just where you need it. A great way to fasten flat, thin materials together, too.

627-516  
\$8.33

### Rechargeable Flashlight-Nightlight

Plug this flashlight directly into your AC socket and it serves as a nightlight, but is also an always charged-up flashlight.

456-420  
\$11.97

### Household Lead Test Kit

Simple color test to determine if your china, paint, or soil has lead.

221-793  
\$5.67

### Carbon Monoxide Alarm

Now that these are inexpensive they should go wherever flames and fire are.

421-846  
\$39.97

### Bath Panel

In 4 x 8 sheets, this 1/8-inch white material makes a very serviceable and very affordable large white board for an office or shop.

628-656  
\$15.62



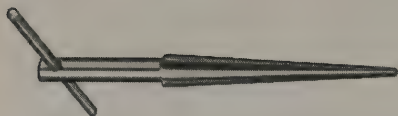

**E** T-Handle Shank,  
Straight Flute

## The handiest simple tool in the world (that most people don't own)

A sheet-metal worker's T-reamer.

This utterly simple no-working-parts hand tool will easily, smoothly, safely, and precisely enlarge round holes (and keep them perfectly round) in any rigid, non-brittle material (i.e. not rubber or leather, not glass, but almost anything else). I discovered this tool by accident when I was twelve years old and have owned one, more or less, ever since. When I lose one, I have to buy another. Costs a few bucks, and, with regular household use, never wears out. Try it. You'll like it. Don't get marooned on a desert island without one.

—William Gibson

### T-Handle Taper Reamer

\$25  
McMaster-Carr  
562/692-5911  
www.mcmaster.com

## Panasonic Cordless Drill Drivers

These drills have the best torque and braking technology I have ever used (and I have used pretty much all of them). These features combined with the newest NiMH 15.6 volt battery tech has let them transcend what we normally think of as cordless tools. They truly rival, and in many applications surpass, some of the best corded drills.

—Alexander Rose

### Panasonic Cordless Drill Drivers

15.6v about \$200  
www.prodcat.panasonic.com/phccdlr/powertools  
/dealloc.asp#locator or 800/338-0552 for dealers



### Battery Cell Temp(F)

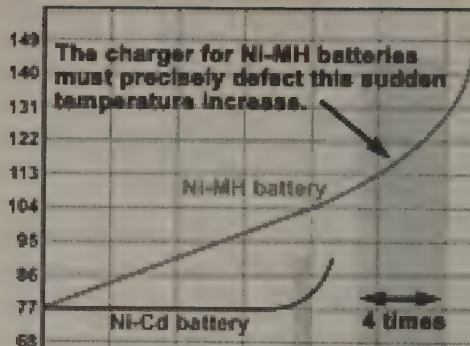

## Rechargeable NiMH Batteries

I use these new Nickel-Hydrate batteries now in my radios, flashlights etc. I hate throwing away little environmental hazards in the form of Alkalines and I hate always having to buy batteries. These new cells have almost the same operational life as an ordinary Energizer but you can use them over and over and over.

—Alexander Rose

www.sanyobatteries.net  
www.energizer.com  
www.batteries.com

## Dimensionator Tapeless Tape Measurer

A tapeless tape measure! I really like this Zircon ultrasonic measuring tool because as a restoration contractor I can walk into a room that is wet, or fire damaged, or very large, and get accurate measurements of its size without having to lay out a tape. I don't need a second person to hold the "dumb end" of the tape, and the device will automatically calculate perimeter, area, and volume as needed. It is fast, and best of all, it is accurate to the inch (or centimeters if you prefer).

—Stephen Seitz

### Dimensionator

\$43.99  
Zircon  
408-866-8600  
www.zircon.com

or Home Depot stores

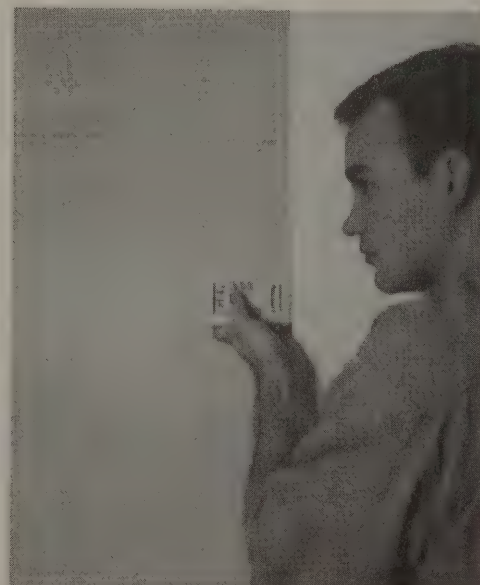
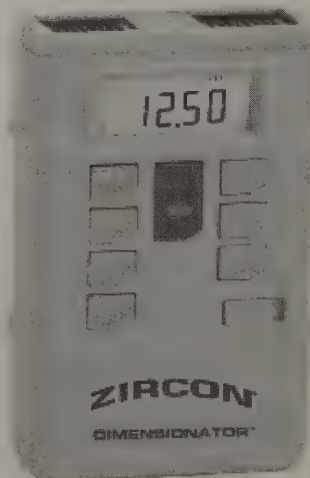



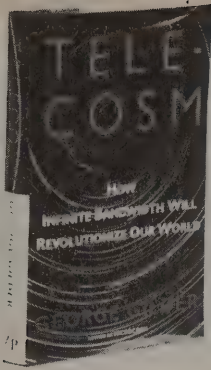

## Telecosm

*What's next? Infinite bandwidth. Not metaphorically infinite, but in actuality: great rivers of instant global communication too cheap to meter. Infinite bandwidth, says techno-optimist Gilder, will be bigger than computers, bigger than the Web, and bigger than the Internet itself. It is the Next Next Thing. The telecosm establishes not only a new infrastructure, but also a new culture and new economy. Gilder's vision is so cosmic, so wild-eyed, so nerdy and technical, and so hyperbolic that in the end I believe him.*

—KK

### Telecosm

**How Infinite Bandwidth Will Revolutionize Our World**

George Gilder  
2000, 351 pages  
\$26  
The Free Press

The economist's focus on scarcity stems from the fact that shortages are measurable and end at zero. They constrain an economic model to produce a clearly calculable result, an identifiable choke point in the industrial circuitry. Abundances are incalculable and have no obvious cap. They tend to end in a near zero price and thus escape economics altogether. As the price declines and their role in the economy becomes more vast and vital, their role in economic analyses diminishes. When they are ubiquitous, like air and water, they are invisible... "externalities." Yet abundances are the driving force in all economic growth and change. In free economies, scarcities find their meaning chiefly in the abundances they engender and constrain.

Nations, companies, and individuals that exploit the "free" abundance (that is, the resource with the plummeting price) gain market share against all rivals.

Every age defines itself by the resource it wastes. Our agrarian forefathers wasted human time. The Victorians wasted coal and iron, the 20th century

wasted electricity. Over the past decade, the world had to learn to waste transistors. Now it needs to learn how to waste bandwidth, and begin rebuilding the world yet again.

Amazingly, most technology prophets fail to come to terms with the power of exponents. You double anything annually for long—whether deforestation in ecological nightmares or transistors on silicon in the awesome routine of microchip progress—and you soon can ignite a sudden moment of metamorphosis: a denuded world or a silicon brain.

As Metcalf explains: "Ethernet works in practice but not in theory." The same could be said of all the devices of the microcosm and telecosm. Both the supreme sciences that sustain computer and communications technology—quantum theory and information theory—are based on probabilistic rather than deterministic models.

Companies that try to banish chance by relying on market research and focus groups do less well than companies that freely make mistakes and learn from them. Because of an ability to absorb shocks, stochastic systems in general are more stable than determinist ones.

The law of the telecosm dictates that the higher the frequency, the shorter the wavelength, the wider the bandwidth, the lower the power, the smaller the antenna, the slimmer the cell and ultimately, the cheaper and better the communication. The working of this law will render obsolete the entire idea of scarce spectrum and launch an era of advances in telecommunications comparable to the recent gains in microchips.

Beginning with the super high frequency spaces above 28 gigahertz microwaves and with all the excess government spectrum now being privatized, the FCC should open up unlicensed spectrum for all to use. Not only can numerous radios operate at non-interfering levels in the same frequency band, they can also see other users' signals and move to avoid them. In baseball jargon, they can hit 'em where they ain't; in a football idiom, they run for daylight. If appropriately handled, these technologies can render spectrum not scarce but abundant.

I log into Amazon or Barnes & Noble and a "cookie" on my computer informs the system of my presence. I play a game of literary preferences. It is a service of Amazon. But it allows the company to alert me to new products that I might like. If they are not just right, I correct them. From my purchases and preferences, Amazon learns how to serve other similar customers. I review a book that I have read. Amazon prints the review. From my purchase and the purchases of others, it contrives a best seller list that is updated every hour. It informs me of the exact performance of all my books. I sell my books from my own webpage, collecting a profit, and Amazon fulfills the order. I am an Amazon customer, supplier, investor, client, author, audience.

## Crypto

*The dashing story of how a bunch of long-hair mavericks wrested control of encryption from the secret society of spooks and installed it on the Web servers of the world, making the Internet world safe for private communication, and for eBay. Crypto is the first truly political movement of the digital era, which doubles the impact of this great tale. Bonus: this book is also the best lay explanation of modern cryptography.*

—KK

### Crypto

**When the Code Rebels Beat the Government Saving Privacy in the Digital Age**

Steven Levy  
2000, 300 pages  
\$24  
Viking

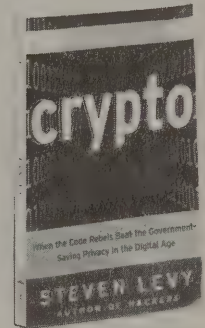

For years, people at The Fort could be reasonably confident that when they devised a breakthrough technique like differential cryptanalysis, such information would be unlikely to tumble into the public domain. Those days were over. Consider that the IBM group had come across the T Attack on its own, without the help of government. Differential cryptanalysis was ultimately a mathematical technique just waiting to be rediscovered by someone outside the Triple Fence interested in sophisticated codes. The NSA couldn't hold on to such mathematical machinations any more than an astronomer discovering a previously unknown nebula could cover up the skies to mask its presence to future stargazers.

This was to be the reality of the dawning era of public crypto: Whether the NSA liked it or not, bright minds were inevitably going to reinvent the techniques and ideas that had been formerly quarantined at Fort Meade—and maybe come up with some ideas never contemplated even by the elite cryptographers behind the Triple Fence.

Digital signatures offer another advantage. Since it is impossible for a digitally signed message to be produced by anyone but the person who holds the private key that scrambles it, a signer cannot reasonably deny his or her role in producing the document. This *non repudiation* feature is the electronic equivalent of a notary public seal.

## My Tiny Life

*Julian Dibbell's story of his multi-year obsession with online MUDS—where he dwelt among virtual communarians, encountered virtual sex, virtual rapes, and virtual executions in a wholly virtual, but tiny, life—is by far the most fast-forward look yet at where real life is headed. Jaded me, I actually got a case of future shock reading it.*

—KK

### My Tiny Life

**Crime and Passion in a Virtual World**

Julian Dibbell  
1999, 304 pages  
\$15  
Owl Books

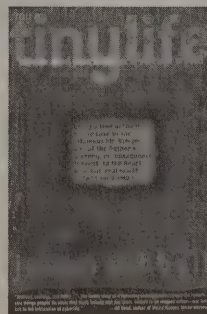

"That first encounter practically blew the roof of my head off," was how Niacin put it. "As sex, it was one of the most amazing experiences I've had, VR or RL.... I almost passed out.... I was at work, all faint and shaky, practically coming in my pants.... I was afraid to move."

And exu, though she tended to be a little less indelicate in her descriptions of what happened that day, was clearly reduced to a similar state of distraction. Logged in from her workplace as well, she too felt almost physically rent by the gap between her mundane surroundings and the place into which her psyche had abruptly been thrust, a place which—well, "What was it like?" I asked, and exu:

"Like white hot. Like nuclear," she said. "It was really like melting into the screen."



## Levenger Lap Desk

Some lean forward to edit or handwrite. I lean back. This light plywood surface (with elastic paper holders) propped on the tiltback chair arms serves admirably as a work surface and then stows easily.  
—SB

## Maple Lap Desk

W9- AC130  
\$30  
Levenger  
800/544-0880  
www.levenger.com

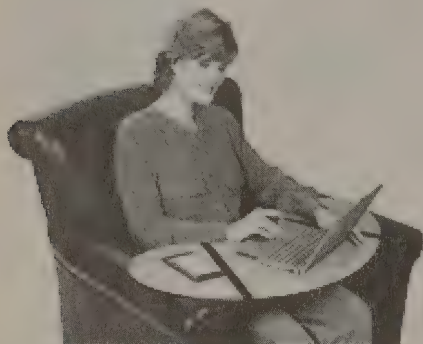

## Low-temperature Glue Gun

A favorite tool, the glue gun, now comes in a low-temperature version which works much better with some materials like foam, and is the preferred one to grab at our house because it is slightly less dangerous for kids to use.  
—KK

## Stanley All-in-One Glue Gun

\$15 at hardware stores



## CD Shrink-Wrap Opener

I have no idea where you can buy one of these. I've only seen them as corporate giveaways. They are the only thing I know of that can open those darned shrink-wrapped CDs. You take this device and zip it along the edges of the jewel box and presto, the wrapping falls away, saving at least 5 minutes of frustrated thrashing. Cultivate a supply because you'll find that they grow legs easily.  
—KK



## CapShare Portable E-Copier

I've found this HP hand scanner to be the most helpful new research tool since the invention of the notecard. It's actually portable and it actually works! Wipe this Walkman-sized device back and forth across your document—in any direction or speed—and the little genie inside reassembles the fragments into a perfect scan, thanks to a double laser eye tracking system. The result is a 300 dpi bitmap or greyscale scan with quality rivaling that of the bulky thing taking up half your desk. Think of it as a portable digital copy machine. A lower resolution mode lets you scan posters up to 4 feet square. And a single button click and the scans are downloaded to your laptop via a wireless infrared port.

I use it to collect and organize all sorts of research fragments. It's popular in legal offices for copying documents on the road. I've used it make digital notecards of newspaper articles, gather text fragments from the library, scan images from airline magazines or conference charts, or to capture a thousand other fleeting texts and images on the go.  
—Jim Mason

## HP CapShare 920 Portable E-Copier

\$300  
www.capshare.com  
www.shopping.hp.com

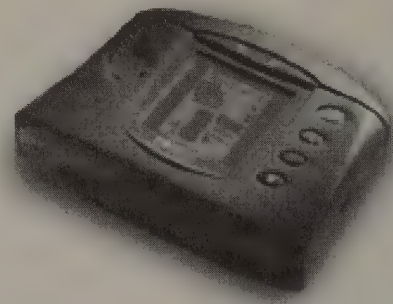

## Fiskars Paper Trimmers

It is simply impossible to make a genuine straight, right-angle cut on paper using a scissors, or even a razor blade and straight edge. The old guillotine paper cutter could deliver a clean cut, but at the risk of taking your fingers away. Fiskars, the scissors makers, invented a tiny blade mounted on a hinged holder that zips through material without any possible harm, even to the youngest children. It's fast, accurate, and crisp. These devices are so handy you'll want a big one for large-sized sheets and a little one for trimming up photos, badges, and whatnot.  
—KK

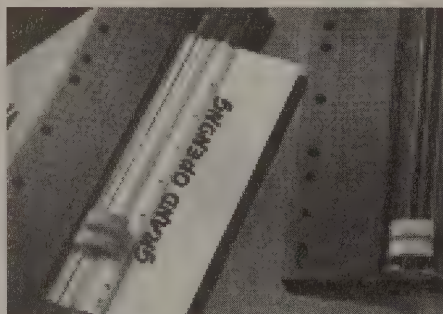

## Fiskars Paper Trimmer

\$20, personal 8 inches wide  
\$45, professional 12 inches wide  
www.crafts.fiskars.com

## Sheaffer Targa Fountain Pen

I own about 100 fountain pens, but this is my everyday pen. Not the fanciest, but a steady performer. Never leaks on planes, and a nice thin line that allows me to also draw with it. Writing with a fountain pen is a delight—after you've used one for a while, using a disposable feels like a depraved act.  
—Paul Saffo

The Sheaffer Targa Pen is no longer in production, but new "vintage" units can be found on the Web. Try, for example Jim's Fountain Pen Site ([www.jimgaston.com](http://www.jimgaston.com)) where one lists for \$70.



## File Philosophy

My philosophy is to file "too much"—whether e-mail, notes, or pieces of paper. It does not cost me any mental energy to have everything sit there in a file. If I do need it, I can find it. The search tools on the mail program Eudora, for example, are great. I'm not embarrassed to file things that really should be thrown away. It's faster to file too much rather than agonize over what to save. Save it all. For instance, one good tool is the "receipt shoebox." Normally you don't need a receipt for something you bought, but when you need one, you really need one! So you toss all (that is the secret!) receipts in a box—chronologically. You dig for one when you need it.  
—Ted Kaehler



## Eames Design

*Design is hip these days. Long before it was hip, Charles and Ray Eames pioneered the design approach to life. Nowhere is their legacy so well represented as in this single-volume exhibit covering every project in their life's work. The Eameses were probably the tech-friendliest designers ever, without ever being hi-tech. They certainly were the first on the frontiers of exhibit, museum, and informational film design. They designed types of things that had never been designed before. This book, together with the two-volume video of their brilliant short films, makes it clear that the Eames pursued their passions first. As design goes commercial in a big way, theirs is a mighty inspiring stance. This is the most comprehensive and graphic record of not only their work (3,500 images) but perhaps of any designer's work. I use this book to expand my notions of what can be designed.*

—KK

Young viewer watching a Mathematics Peep Show. These films were called "peep shows" because they were first shown in devices designed to accommodate one viewer. They were intended for a short attention span; each two-minute film explored one mathematical concept and could be seen as many times as a viewer needed to understand the idea.

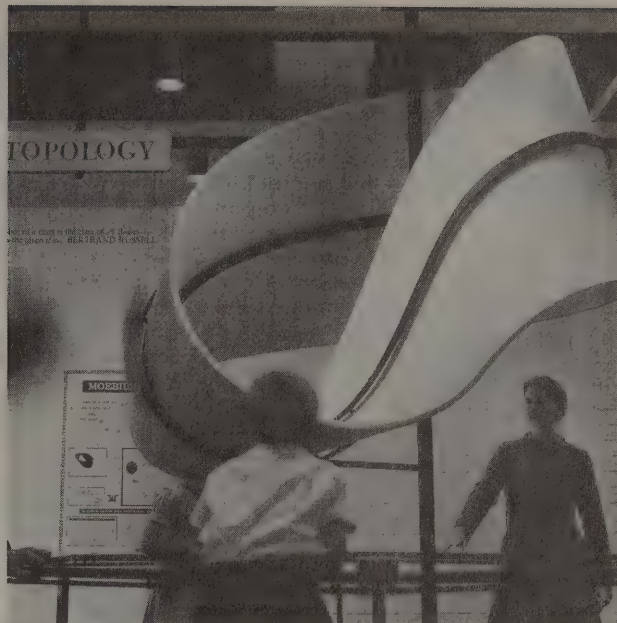

The Moebius Band with its traveling red arrow. The arrow is started on its path by pushing a button. 1961.

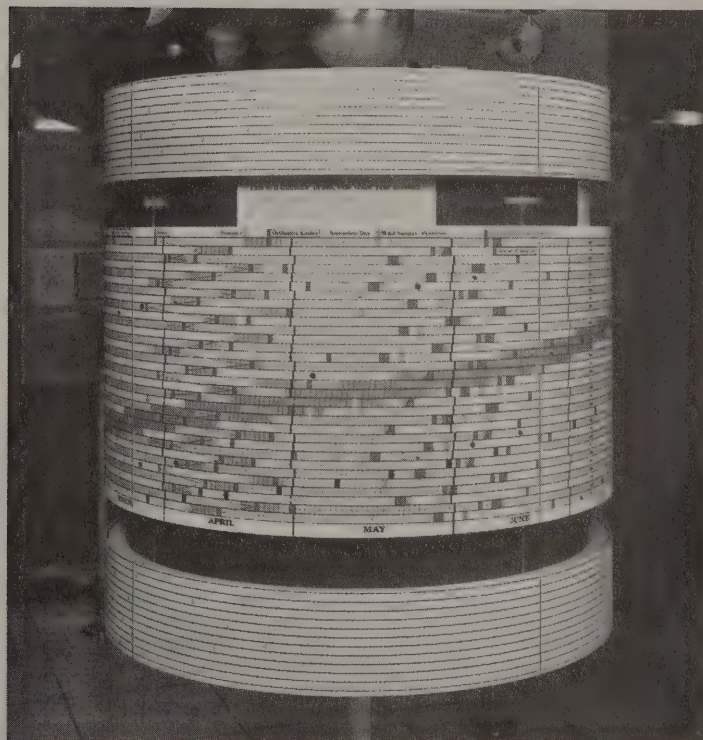

A large drum made in the Eames Office demonstrated how calendar years and feast days are determined. The drum was divided into horizontal strips, each of which represented one solar year, with the succession of days and full moons marked. The drum charted certain seasonal celebrations—Christian Easter, Orthodox Easter, Passover, Rosh Hashanah, Ramadan, Islamic New Year, winter and summer solstices, vernal/and autumnal equinoxes, Thanksgiving and leap-year day—and showed how their dates change from year to year.

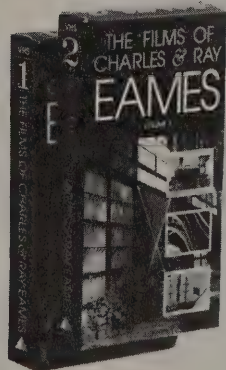
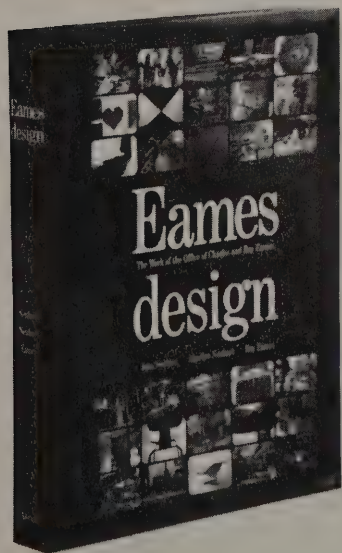

### Eames Design

**The Work of the Office of Charles and Ray Eames**

John Neuhart, Marilyn Neuhart, and Ray Eames

1989, 456 pages

\$95

Harry N. Abrams

### The Films of Charles and Ray Eames

Vol. 1: Powers of Ten

Vol. 2: Toccata for Toy Trains, House: After Five Years of Living, Atlas, Blacktop

Vol. 4: Mathematics Peep Show, Design Workshop, Chairs, Goods, Copernicus

1989, Vol. 1: 21 minutes, Vol 2: 62 minutes, Vol. 4: 59 minutes

\$24.99 DVD, \$39.99 VHS

www.eamesoffice.com, 310/396-5991



# Bloggging

Report and Illustrations by Mark Frauenfelder

*The first approximation of an innovation goes only halfway to realizing its full impact. Two generations ago many people imagined a horseless-carriage, or automobile. However, very few imagined the second-order disruption of this horseless carriage—parking lots and traffic jams. And virtually no one foresaw the third-order consequence of this second-order disruption (car plus parking lot) which was suburbia.*

*Hyperlinking—the foundation of the Web—had long been prophesized by visionaries like Ted Nelson and others. In fact their descriptions of how hyperlinking would work were very prescient. But neither Ted Nelson, nor anyone else involved in pioneering hypertext (including we who worked on the early hyperlinked version of the Whole Earth Catalog in 1986) ever imagined the most profitable (to date) use of hyperlinking, which is to sell junk on eBay.*

*The following report is an early look at another unexpected use of hyperlinking, another one that escaped anyone's prediction. It is hard to tell whether this is a trivial exploitation of this technology, or profound. The author, Mark Frauenfelder, has a great track record for uncovering street uses of technology that later play out large. Mark, in fact, was the first person to alert me to eBay, when it was still just a small-time Bay Area flea market for collectors and Beanie Baby fanatics. Mark once published a popular zine of street trends called Boing Boing, and was an early Wired editor.*

*I grabbed this report which he had circulated to several magazines after they rejected it because it was too "fringe." On theWeb, fringe is front and center.*

—KK

WHAT CAN YOU WRITE ABOUT A WEB SITE, BESIDES "IT'S COOL," OR "IT'S NOT COOL?" wondered Jorn Barger. But when you link to an interesting article within a site, there's plenty to write about, and if you're smart, funny, or outrageous, eventually you're going to get a following of regular visitors—as Barger does, in his extraordinary and eclectic Robot Wisdom ([www.robotwisdom.com](http://www.robotwisdom.com)), one of a growing breed of self-expressive Web sites for which Barger coined the term "weblogs."

Weblogs (or blogs, as the blogging inner circle sometimes calls them) are different from "favorite site" lists, which are typically just a bunch of links to the front pages of sites. Weblogs link to specific pages, otherwise known as "deep links." The purpose of a Weblog is not just to recommend URLs, but to opine on them as well. Think of a weblog as a journal of one person's explorations as he or she cruises uncharted sectors of the Net, reporting on the interesting life-forms and geological formations.

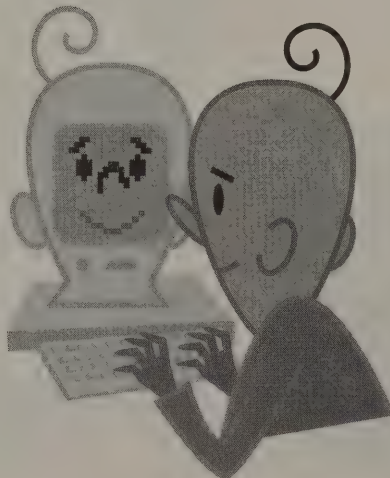

The people who publish weblogs are like pre-surfers, or tour guides. There's a blog for every taste. The best are published by opinionated, perceptive people who write about sites you might never find on your own. A blog's links reveal the blogger's worldview. "They're an online extension of yourself," explains Cameron Barrett, a Web designer from Ann Arbor, Mich., who publishes [www.camworld.com](http://www.camworld.com).

Weblogs are as different as the people who publish them. Some are close to being headline aggregators, such as Robot Wisdom, which consists mostly of links, short descriptions, and excerpted sentences from news stories he finds—"Detailed critique of MacOS-X's new Aqua interface," "Michael Gross on the fashion-model-agency sex scandals." Others are more like online diaries: Paul Perry's [Alamut.com](http://Alamut.com) is light on links, but heavy on personal introspection—"It was a month ago, on the 26th of December, that the fundament of my earthly kingdom, the love of my life, announced the end of our seven-year



relationship.” Occasionally, blogs end up delivering too much personal info, like this example from RiotHero.com, maintained by a 15-year-old boy: “[4:45] Oh shit. Lyda is coming over now, and I’m going to take a shower before she comes. (We’ve been dating only 4 months... so I’m still trying to impress her with my ‘fresh’ scent.)”

Does Lyda know what’s in store for her?

Weblogs aren’t just all fun and games. Some, like Xblog (<http://www.xplane.com/xblog/>) should be required reading for anyone involved in digital design. Companies are increasingly getting in on the blog action. Vincent O’Keeffe, a “user experience architect” for Octagon Technologies, a Web development company in Dublin, Ireland, says he maintains a weblog “to keep track of net flotsam and jetsam that I think is interesting to me and to the rest of the team in relation to projects we’re working on.” O’Keeffe uses a free Web-based weblog creation tool from Blogger.com to publish his internal weblog. Blogger.com, and weblogs, he says, are “a complete paradigm shift in the way I browse and learn—like a limb I never knew I missed until I found it.”

Sean Carton, co-owner of Carton-Donofrio Interactive, a Web advertising agency in Baltimore, Mary., says public weblogs will start showing up on more commercial sites, too. “Everyone’s trying to build bogus ‘community’ sites with bbs software, but they don’t always work so well. Weblogs succeed because they combine commentary with content—always a nifty combo.” Carton points to Streettech.com, a hardware and software review site that his company owns. Carton says the addition of a weblog to Street Tech has resulted in a “rapid increase in traffic” to the site.

Bloggging has exploded. Last year, there were fewer than twenty self-described weblogs. Today, there are probably close to a thousand. Look for at least ten times as many next year. Why is bloggging so popular? First, it takes some time for any infectious idea to incubate before it erupts on the Web. (eBay was just a hangout for Pez collectors before it took off.) Second, the Web has long been home to tens of thousands of different cultures, but there hasn’t been a culture for the Web; not until bloggers came along. Now that the phenomenon has a label, people recognize blogs as a new form of Web-enabled literary self-expression, and the urge to start one is irresistible. Third, as the Web gets bigger (one billion pages and growing) it’s only natural that new ways to dig up the good dirt will be invented. Search engines are fine if you already know what you want. But what if you don’t know what you want, other than to be surprised or inspired? You could try a randomizer,

like roulette.com, but you’ll have to endure lots of “this domain for sale!” and “file not found” pages before you land on something even mildly interesting. Weblogs, on the other hand, are serendipity search engines, run by humans, returning treasures that you could never have found yourself.

In the same way that Tripod and GeoCities made it easy (some snobs would say too easy) for anyone to put together a home page, sites like Blogger.com, Manilla.com, Pitas.com, and Groksoup.com offer one-stop-blog-making tools. Blogger, the most popular, lets you add a site to your blog by right-clicking on a Web page and selecting “Blog This!” from the menu. A form pops up that lets you add comments, and the whole thing is instantly published on your blog. Be-cause it’s so damn simple to use, Blogger is responsible for a number of ultra-low-grade weblogs. What’s needed is a blog that reports on the best blogs—a metablog. Of course, there already are a bunch, like Metablog ([www.well.com/user/gtk/metablog.html](http://www.well.com/user/gtk/metablog.html)). There are even meta-metablogs, but our heads will pop if we go any further down that trail.

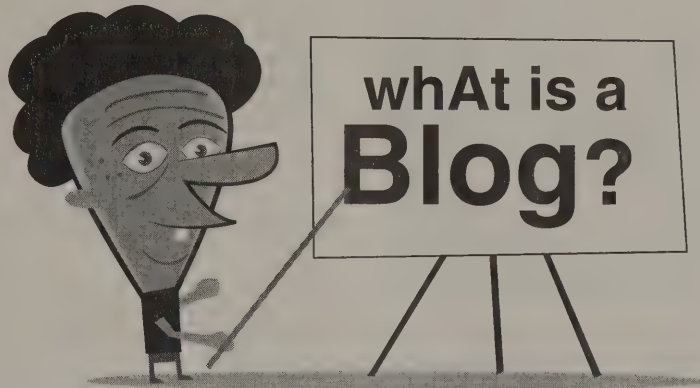

Some clueless media companies—terrified of losing their precious banner ad revenue—have threatened webloggers not to link directly to articles in their sites. They don’t want visitors to skip by the ads hanging on the front door and head right for the article. For example, Spin.com has a posted policy that reads, in part, “Any link must not frame the Owners’ site and must be to the entire site rather than to a particular page or graphic. Owners reserve the right to request any linking site to remove such link to any Owners site. Any linking site agrees to comply with such a request within 24 hours of receipt of such a request from Owners.” Universal Studios recently sicced its lawyers on Jean-Pierre Bazinet, who runs Movie-List.com, for linking to the studio’s movie trailers. Universal wrote Bazinet, “You are not permitted to link to other sites that contain our copyrighted material without our authorization.” Bazinet’s service provider, Simplenet, agreed with Universal’s demands, explaining “You are not a registered search engine.” (Simplenet didn’t even supply poor Bazinet with the contact information for the Intergalactic Search Engine Registration Authority, either!) What kind of Web would we have if everyone needed to get permission to link to a site, cry webloggers? A broken one. Many bloggers say they’ll simply “boycott” the companies that enforce such a ridiculous policy. That’s the allure of webloggging, you have the power to decide what to serve your readers, who depend on you to filter out the junk.

Why start a weblog? Most bloggers explain that they were already sending frequent e-mail to friends about interesting things they’d come across, and figured a weblog would be a



better way to share. Others say publishing a blog is a way to make them feel as if there's a purpose to their meandering through little-known corners of the Web. Still others incorporate their weblogs into their work. Dan Gillmore, the technology columnist for the *San Jose Mercury News*, has been publishing his weblog, eJournal (<http://weblog.mercurycenter.com/ejournal/>), on his newspaper's site since October 1999. In his blog, Gillmore occasionally tells readers what he's working on in an upcoming print column, even asking them for their ideas. "It's almost a liberating idea," he says. "It's not something that journalists ought to be afraid of." Of the three columns Gillmore writes for the print version of the *Merc* each week, one consists of the best items from eJournal.

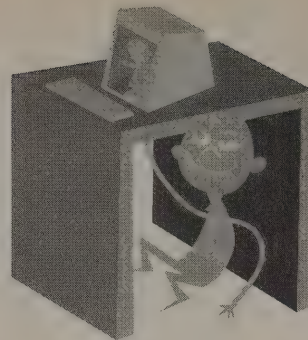

for being self-indulgent," says Ray Davis, the 41-year-old publisher of the Hotsy-Totsy Club ([www.kokonino.com/pubs.html](http://www.kokonino.com/pubs.html)), a highly-amusing blog that covers everything from vintage Viewmaster reels to Internet industry news. Davis enjoys the fact that he's got an audience, but he's a realist—he doesn't expect his server to shut down anytime soon with readers flocking to his site. "I know the readers who'd enjoy my crypto-cornpone ill-tempered

conscience-ridden style are a small minority," says Davis, a computer programmer and Web designer. "I just want as many of that minority as possible to get a chance to enjoy it."

To blog is to be part of a community of smart, tech-savvy people who want to be on the forefront of a new literary undertaking. In the spirit of camaraderie and self-promotion, Bloggers swap tiny banner ads with each other, using a free service offered by scripting-guru Dave Winer at [www.weblogs.com](http://www.weblogs.com); they send fan mail to each other, they cite other's blogs, and they participate in a half-dozen forums, including mailing lists, message boards, and collaborative blogs (blogs maintained by communities of bloggers, which usually lack the quirky snap of a solo blog).

It's not all buddy-buddy in blogland. Last August, several webloggers became flustered and argumentative when Jorn Barger—the inventor of the word "weblog"—posted a list of other people's blogs that he found too "overdesigned," "garish," or "database-y." And in January, Camworld complained that Wetlog was copying Uselt's page design. "It's hard to tell if this is a parody, or blatant theft," Cameron Barrett posted on his blog. "Maybe it's a cry for help from someone who feels he needs to pull a stunt like this to draw attention to his site." The comment ignited a blog brushfire. The next day, Oneswellfoop launched Scamworld, a parody of Camworld. Weblogger Mike Gunderloy got in on the action, posting to Larkfarm: "Some folks need to take a deep breath and repeat 'it's only a Web site' a few times," and pointed out that "Uselt's own copyright statement says explicitly 'You are welcome to copy my CSS style sheet.'" Then, a bunch of bloggers went over to Metafilter to discuss the events. Cameron, too, joined the fray at Metafilter. He admitted he's got easily-pushed "hot-buttons" and vowed to sweep the issue under the rug. Currently, people are pissed off at Dlog (<http://andy.newdream.net/dlog/>) for daring to critique the designs of other people's weblogs.

Webloggers write a lot about what it means to be a weblogger, much in the style of rock bands that play songs about living the rock 'n' roll lifestyle. But what do you expect? This is vanity press, a well-known stomping ground for giant egos. Blogging is a get-noticed-quick-scheme of the attention economy. "Like most of the writers I know, I want to be rewarded

## WEBLOGS SITES AND SOURCES

A large number of weblogs focus on Web design issues, since many bloggers are designers. Here are a few of the best:

Uselt.com ([www.useit.com](http://www.useit.com)) by Jakob Nielsen, formerly Sun Microsystem's Web usability guru and now a user interface consultant, is a fast-loading text-only site with daily items about the wisdom of simplicity in design.

Xblog ([www.xplane.com/xblog/](http://www.xplane.com/xblog/)) is a daily list of links to graphics and design articles.

Kottke.org is the "Home of Fine Hypertext Products," maintained by Web Designer Jason Kottke. You're just as likely to find a hysterical right-on timeline of the evolution of portals as you are instructions on how to opt out of DoubleClick's tracking cookies.

Other blogs cover razor-thin niches:

The US President Biography Project ([biography.ediththispage.com/](http://biography.ediththispage.com/)) links to articles on the Web about what else?—US Presidents.

Mozillazine ([www.mozillazine.org](http://www.mozillazine.org)) covers the latest news about Netscape's open source browser project.

Scripting News ([www.news.userland.com/](http://www.news.userland.com/)) is Dave Winer's blog about programming-related news articles that appear in online tech publications. He also hosts a site called [weblogs.com](http://weblogs.com), full of tools and tips for bloggers. Over 300 people have registered their weblogs on his site.

Larkfarm ([www.larkfarm.com](http://www.larkfarm.com)) is maintained by an old-time zine publisher and reviewer who hasn't been able to resist the enticement of weblogs. Mike Gunderloy, who published the incredible *Factsheet Five* (sort of like a blog for self-published magazines) in the 1980s, now reviews other weblogs, in addition to finding and commenting on the sites he comes across.

Blog Portal ([www.eatonweb.com/portal/](http://www.eatonweb.com/portal/)) attempts to list and categorize hundreds of blogs out there. The publisher, Brigitte Eaton, says that the number of new blogs popping up every day has made it difficult to maintain the portal.



# Really Useful Web Sites

*I'm not the only one tired of seeing Yet Another Web Site. Visiting a new site is now low on my list, and returning to one is rarer still. Yet...there are some truly useful ones out there, providing novel services that warrant repeat visits. Some ought to be better known. Recently I surveyed my circle of friends and asked them to suggest a couple of Web sites that they used often and gladly. The ones I didn't know I tried out a while; the ones I kept returning to I present in this annotated list. Not included are content and news sites, or good destinations with specific niche appeal. With a few exceptions I list here primarily sites that act as general purpose tools.*

—KK



## eGroups ([www.egroups.com](http://www.egroups.com))

Anytime you find yourself having to manage an ad hoc or emergent group, head to this site. It offers an easy way to send out mailings to a list of people and coordinate their replies. It also offers calendars for groups, automated reminders for groups, and other community-minded features. It's used with gratitude by book club members, parent organizations, one-time panels, and anyone else in a conspiracy to accomplish something.

## Evite ([www.evite.com](http://www.evite.com))

Another group-oriented site, this one smoothes the chore of coordinating the schedules of people who are not only dispersed widely but who often don't know each other. Its simplest function is to invite a bunch of people to a party or meeting, with the option of having invitees share the emerging list of who's coming, so that the invitation becomes a truly group effort. It's so convenient and handy to use that students on college campuses use it to coordinate evening get-togethers.



## PayPal ([www.paypal.com](http://www.paypal.com))

I've been waiting for years for true peer-to-peer electronic money to arrive. Well, it's here. PayPal allows you to e-mail (for free) as little as \$1 to anyone with an e-mail address. To collect the dollar (or more) the recipient needs to sign up with PayPal (free) and give them a bank account to put the money into. Once signed up, they can both send money from that account (or from a credit card) or receive money sent to them by others. It is by far the easiest way to pay someone. It's free, fast, secure, and unbelievably convenient. It's also becoming the preferred method of payment on the auction sites.

## Universal Currency Converter ([www.xe.net/ucc/](http://www.xe.net/ucc/))

There is nothing like it. Calculators and stale financial pages just won't do. For finding out how many pesos in a Thai baht, or what that cab ride in Cairo cost in dollars, this is the place to go. For those who travel overseas a lot, this is the only sane way to deal with those foreign receipts.



## Encyclopedia Britannica ([www.britannica.com](http://www.britannica.com))

One of the first brash predictions made in the dawn of the digital age was that you would never need to buy a bookcase of heavy encyclopedias again because all that knowledge would be online at your fingertips. This is one of those rare predictions that came true. The venerable, trustworthy, and still useful Encyclopedia Britannica is not only on the Web in full, but it's free. Once you bookmark it, you'll use it all the time.

## Individual.com ([www.individual.com](http://www.individual.com))

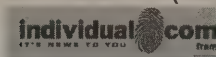

A free clipping service that e-mails you headlines or summaries of whatever subjects you ask for. (Or you can go to a personal Web page.) The bias is weighted

toward technology and business topics, but still, the thing churns up a daily roundup on some of my oddball interests like religious cults or alternative energy sources.

## Google ([www.google.com](http://www.google.com))

If Google isn't your primary search engine, you are searching with one eye closed. This is the best search site so far.

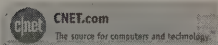
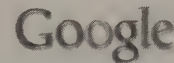

## CNET ([www.cnet.com](http://www.cnet.com))

Ignore the news department; what this site offers is the best recommendations for electronic and computer shopping around. Buying office equipment? Gearing up for digital photography? Cnet has the smartest, broadest, and easiest to use recommendations for what to buy in popular consumer electronics.

## Epinions ([www.epinions.com](http://www.epinions.com))

For recommendations on almost anything made. Movies, gear, ski slopes, other Web sites. The genius of epinions is an ever-evolving set of tools that lend credence and trustworthiness to informed consumer opinions. Users recommend products and rank the opinions of others. The highest-ranked opinions and products are highlighted, while the best reviewers are made into stars, and the stuff with the best reviews rises. This is where I go when I want to find the street cred on something. And if you have opinions about something this is the place to post them. It's sort of a peer-to-peer open-source version of *Consumer Reports*.



## eLance ([www.elance.com](http://www.elance.com))

## Guru.com ([www.guru.com](http://www.guru.com))

I recently needed various freelance work done, which ranged from technical wizardry, to graphic expertise, to someone to wire up my house with Ethernet. I found the right person at the right price on either guru.com or eLance.com.

## eBay ([www.ebay.com](http://www.ebay.com))

People think of eBay as a place to swap Barbie dolls and old lunchboxes, but it turns out that eBay is the best place to find ANYTHING that is hard to find. It is now the first source people check when in need of something new or old. eBay has yet to stump me, or anyone else I know, when asked to find some obscure item. (See fuller review, page 42).



## Bibliofind ([www.bibliofind.com](http://www.bibliofind.com))



Everyone knows about Amazon. They are still the best for stuff "in print." Some people go to Powells.com for books because Powells will offer both new as well as used copies. But to harness the full power of distributed intelligence, go to Bibliofind whenever you are searching for an out-of-print book. Bibliofind aggregates the holdings of thousands of used bookstores around the US, allowing you to search once to immediately see all the copies available, and—this is the cool part—compare prices. You can then order directly from the store of your choice. This means increasingly there is little distinction between books in print and out. You can usually find any book at a reasonable price.



## MyYahoo ([www.my.yahoo.com](http://www.my.yahoo.com))

MyYahoo has emerged as the default homepage for most of the people I know. Smart and flexible, it allows both novice and veteran alike to direct their choice of headlines, stock quotes, weather, favorite sites, reports, etc. onto one constantly updated page. Ten years ago this ability to have any and all information you wanted updated hourly on one page would have been pure visionary baloney. Now it's free, works perfectly, and is overlooked. One radical poweruser I know does everything on Yahoo, including his e-mail and storage of all his files. He has ditched his computer and PDA while travelling since all he needs is access to someone's Web to get to his Yahoo and he can work.

*Thanks to Amy Jo Kim, Bruce Sterling, Alexander Rose, Doug Carlston, Hal Varian, Stewart Brand, and others for their suggestions.*



FIGURE 4.1  
THE MEMBERSHIP LIFE CYCLE  
The five essential stages of community membership

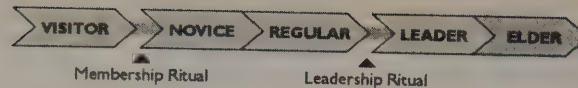

## Community Building on the Web

*This is the guidebook I hand out to anyone serious about building online communities. Not just merchants, but citizen groups, hobbyists, ethnic supporters—anyone nurturing an embryonic tribe. Most of what we know so far about how to build real communities on the Web is contained herein.*

—KK

### Community Building on the Web Secret Strategies for Successful Online Communities

Amy Jo Kim  
2000, 360 pages  
\$29.99  
Peachpit Press  
www.peachpit.com

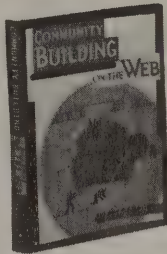

Any community with a rating system can have "champions" by highlighting the top performers—for example, eBay acknowledges and rewards members with the highest feedback scores. And Motley Fool uses their message board rating system to showcase members whose posts are consistently highly rated. Again, drawing attention to good performance will show all your members what success looks like and will motivate some of your most valuable members to stay involved.

If you are running a small, not-for-profit community like a bookclub or mutual support group, you'll naturally turn to volunteers. But if you've got a growing Web community that has strategic goals and quarterly budget reports, deciding who gets paid and who doesn't becomes more complicated. Some communities, like the Motley Fool, avoid the issue altogether by having all their official community leaders on staff. With paid leaders, you'll retain more control over your brand and be able to run a more professional organization because staff and contractors are legally bound to fulfill their duties. On the other hand, a struggling Web community can incur a serious financial burden if it relies solely on paid leaders.

Most large-scale Web communities—like Talk City, Ultima Online, GeoCities, Simutronics, CNN, and AOL—walk this line by developing a tiered leadership structure that includes full-time staff, part-time contractors, and shifting ranks of volunteers. If you expect to have such a mix, you should launch your leadership program with paid, experienced leaders if you can afford it. This will let you attract people who know what they're doing, avoid the ambiguities of dealing with volunteers, and get your program off on the right foot. These experienced leaders can then help you set up the infrastructure and policies for your volunteer leadership program.

## Guerrilla Wireless

*By combining some off-the-shelf gear, you can build a robust and very fast wireless network that takes you completely out of the normal telecom model of hooking people to the Net. The new 802.11 wireless Ethernet standard has spawned the creation of dozens of 2.4 Ghz wireless networking products. The beauty of this emerging system is that you can quickly (no wires!) connect thousands of people together at speeds up to 11Mbit (fast enough to send video). Plug this guerrilla wireless network into someone's ordinary \$50/month DSL connection, or a T1 line, or Satellite uplink, and now everyone in the network is on the Internet!*

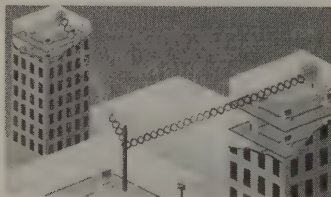

*With this technology you can build a pervasive wireless network that reaches out between one and 15 miles (depending on terrain). You could then set up a relay radio every one–15 miles and stretch that network out infinitely. You could wire up a county or even small state this way. At the Burning Man festival this year, I helped build a satellite uplinked version of this network, with capacity and range for 30,000 people, and it was up and running in only a few days. Instant Internet for a city.*

*To accomplish this you'll need something like the AeroNet/Cisco 340 series server, which costs about \$800–\$1400. You hook that up to a just-under-the-legal-limit amplifier and antenna by WaveLAN (kit price about \$800). And you'll need something to give out IP addresses, like one of the Netopia DHCP router boxes. Computers participating in the network need a wireless modem card; these range from about \$100–\$300.*

—Alexander Rose

Wireless Internet Models/Explanations:  
www.aironet.com/wireless/  
www.aironet.com/markets/isp\_cyber.asp

www.beyond.com  
Netopia R-Series Frac T1/T1 Router Module, \$554.99

www.cdw.com  
Cisco Aironet 340 11Mbps DSSS Access Point with 40-bit WEP, \$968  
11Mbps DSSS wireless bridge for building-to-building, \$1,409.63  
Cisco Aironet Low Loss Antenna 75' Cable 5.0 dBi antenna, \$115.26  
11Mbps DSSS PCI adapter for Aironet 340 series, \$277.12  
Cisco Aironet 340 11 Mbps DSSS PC Card Adapter, \$187.22

www.wavelan.net/2400SX.htm  
HyperAmp HA2400SX, \$545.00  
Amplified 8dB Omnidirectional Antenna Kit for WaveLAN IEEE/Turbo, \$785.00

## Webconferencing

Ever try to carry on group conversations about sixteen subjects at once via mailing list? Worse, have you ever tried to find that one post in those sixteen subjects that you needed? An e-mail list is often not enough. Much better is Webconferencing software which structures a group's correspondence by subject into neat hierarchies (conference, topic, post), and then enables easy navigation of discussions that may continue for weeks or even years. These structured posts serve as a group memory that can create a knowledge repository. Webconferencing therefore combines the capabilities of good peer-to-peer communications with the capabilities of the Web. Several moderately priced Webconferencing products now make it possible for your group, community, company, or social network to mix informal and serious discourse in the same social cyberspace. The better products enable multimedia posts and the ability to add URLs within posts, as well as diagrams, illustrations, or other graphics in the context of a discussion.

Two of the very best and most affordable Webconferencing products are WebCrossing and Motet. I have used both systems as a participant in many conferences, and more importantly, as a person setting up and hosting many conferences on the Web. Both of these packages have the essential features of a desirable Webconferencing system—subscription lists so you can tailor your participation to follow only those discussions that interest you, discussions structured as streams of comments (and not as collections of documents, the way Lotus Notes and other stupid pre-Web groupware does).

The two programs have slightly different interface styles. WebCrossing includes fully integrated read-and-post-via-e-mail and chat features, and a more detailed administrative control panel. If you have a larger number of users or you run an educational institution, Motet offers a better deal financially. WebCrossing comes in three versions: free with ads,



paid without ads, or free without ads below a certain level of activity. If you are willing to put up with their banner advertisements, WebCrossing will host your community for free on their servers. If you want them to host without the ads, WebCrossing costs start at \$1.50 per thousand pageviews. You can license and install their software on your own server without charge if you have less than 1,000 page views daily—a great way to see how you like the product. A half-dozen people, and a half-dozen conferences, with a half-dozen topics, probably won't go over a thousand page views per day. Beyond that and you'll need the paid or advertising version.



Motet has a straight one-time license fee of \$1,995 per site, with no subsequent annual charges. A license for fifty or fewer registered users is \$995. Accredited educational institutions and nonprofits can license it for \$500.

Both programs will run on most Webservers. The ultimate information source for Webconferencing products and services is <http://thinkofit.com/webconf/>.

—Howard Rheingold

www.webcrossing.com  
www.motet.com



## The Tipping Point

Consider this a primer on how to change the world by changing only a few small things. If you can launch the germ of an idea in the right context, then a little shove can push that idea into taking over the entire world. Think hulu hoops and environmentalism. That small, critical nudge is known as the tipping point. Gladwell digs deep into social science to uncover all manner of marvelous research on how ideas propagate via friend-of-a-friend networks (he has the real story of the famous six degrees of separation) so that by leveraging the logic of networks, a whisper becomes a shout.

—KK

## The Tipping Point

### How Little Things Can Make a Big Difference

Malcolm Gladwell  
2000, 279 pages  
\$25  
Little, Brown

*The Tipping Point* is the biography of an idea, and the idea is very simple. It is that the best way to understand the emergence of fashion trends, the ebbs and flow of crime waves, or for that matter, the transformation of unknown books into bestsellers, or the rise of teenage smoking, or the phenomena of word of mouth, or any number of the other mysterious changes that mark everyday life is to think of them as epidemics.

In all of the city of Colorado Springs—a town of well in excess of 100,000 people—the epidemic of gonorrhea tipped because of the activities of 168 people living in four small neighborhoods and basically frequenting the same six bars.

Six degrees of separation doesn't mean that everyone is linked to everyone else in just six steps. It means that a very small number of people are linked to everyone else in a few steps, and the rest of us are linked to the world through those special few.

When it comes to finding out about new jobs—or, for that matter, new information, or new ideas—"weak ties" are always more important than strong ties. Your friends [strong ties], after all, occupy the same world as you do.... How much, then, would they know that you wouldn't know? Your acquaintances [weak ties], on the other hand, by definition occupy a very different world than you. They are much more likely to know something that you don't. To capture this apparent paradox, Granovetter coined a marvelous phrase: the strength of weak ties.

The Power of Context says you don't have to solve the big problems to solve crime. You can prevent crime just by scrubbing off graffiti and arresting fare-beaters; crime epidemics have Tipping Points every bit as simple and straightforward as syphilis in Baltimore or a fashion trend like Hush Puppies.

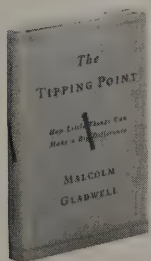

## The Self-Made Tapestry

The most comprehensive, and most comprehensible analysis of patterns in nature and the nature of patterns.

—KK

## The Self-Made Tapestry

### Pattern Formation in Nature

Philip Ball  
1998, 324 pages  
\$37.50  
Oxford University Press

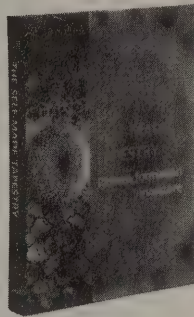

The Paris Metro is a branched network with a fractal form.

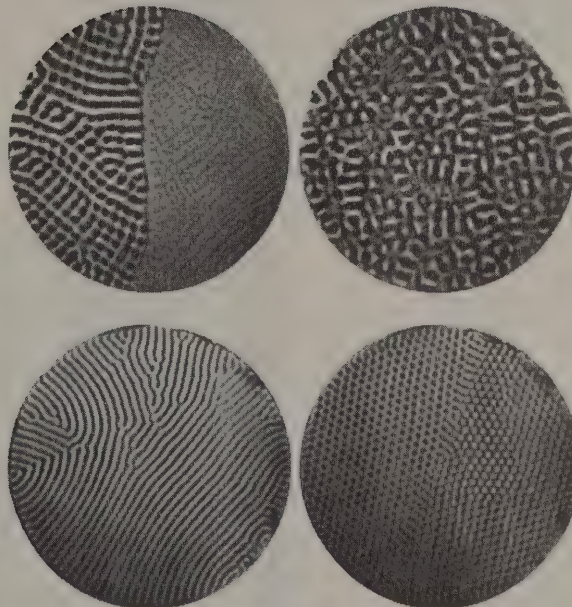

When shaken vertically, a shallow layer of grains can develop complex wave patterns, including stripes, square and hexagonal patterns.

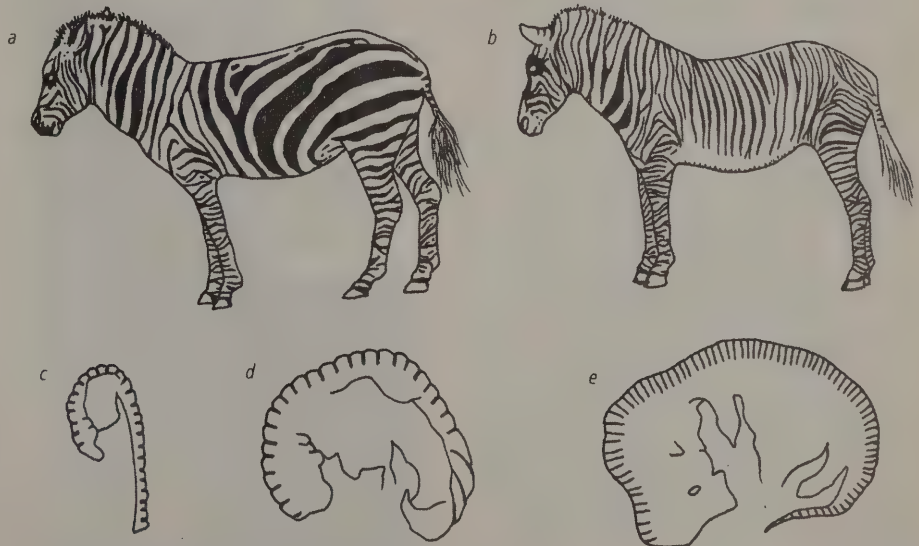

The adult zebra *Equus grevyi* (b) has more and narrower stripes than the adult *Equus burchelli* (a). This is thought to be because the striped 'pre-pattern' is laid down on the embryo of the latter at an earlier stage: after twenty-one days for *Equus burchelli* (c), but after five weeks for *Equus grevyi* (e). The smaller embryo supports fewer stripes, and so by the time it is of comparable size (d), its stripes are wider.



# True Films

When it comes to guides to the best movies, you have plenty to choose from; dependable reviewers like Leonard Maltin will steer discriminating film buffs to the right stuff. Then there is the Internet Movie Database ([www.imdb.com](http://www.imdb.com)), a self-correcting opus containing everything anyone would want to know about any film. For fictional cinema, you're covered.

But when it comes to nonfictional films—what Americans call documentaries and the British call factuals—guidance is scarce.

I haven't been able to find an accessible clearinghouse that reviews and evaluates factual films. In general the steady river of "true films"—documentaries, science programs, video courses, nature shows, and news specials—is usually ignored by catalogers and reviewers. This neglect is similar to the neglect of nonfiction books in the 1960s. Today if you want to find the best film about gypsies, where do you go? What about the best visual biography of Van Gogh and his work? The huge body of factual work is overlooked, in part because of the sheer daunting numbers of this kind of material produced. The BBC in London has vaults full of fabulous material that is not cataloged for the public in any meaningful way.

My hunch is that true films won't be ignored as soon as it is easy for anyone to download movies to their screen, à la Napster. When you are able to quickly find a copy of that esoteric film of Balinese dance you've always heard about, then the demand for comparative and complete reviews will trigger action.

To jump-start this process and encourage others to add their favorites, Richard Kadrey and I have put together a starter list of really good true films. One or both of us have seen the following factuals and thought they were definitely worth while. All are fairly easily available, either for sale from the usual online sources like Amazon or eBay, or for rent from Netflix (see review below), or on loan from a specialty local rental place (representative prices below are mostly from Amazon). All the works are in English or have English subtitles. We consider this list to be version 1.0, and would like to flesh it out further, probably online.

—Kevin Kelly

## 7 Up, 14 Up, 21 Up, 28 Up, 35 Up, 42 Up

What started out as a British documentary exposing the role of class in a child's destiny has turned into one of the most satisfying works of cultural anthropology and a showcase longitudinal study. Every seven years, starting at the age of seven, we visit the same group of children as they grow up, have dreams, are lost and remade, and in many cases see their lives take the unexpected turn as they age. Because each new film is created to be understood by itself, each recapitulates all the others before it, so there is a lot of repetition from issue to issue, but a lot missing if you only see the last one. —KK  
VHS \$17.99 each volume

## Amazing Grace

The simplest are sometimes the best. This documentary is about one song, "Amazing Grace." An amazing lot can be seen through this four-stanza song. Bill Moyers follows the origins and evolution of one of the world's most famous hymns. It is part music history, part African-American history, and part song itself. —KK  
VHS \$21.99

## Atomic Cafe

No need to mock nuclear power and atomic weapons when the promoters do it so well themselves. This brilliant compilation of mostly government-funded atomic propaganda films is very campy. Imagine a nuclear version of *Reefer Madness*. —RK  
VHS, \$26.99

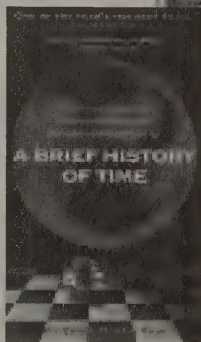
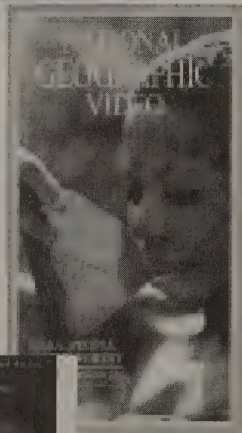
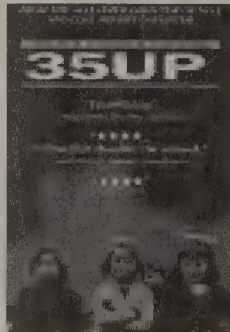

## Baka: The People of the Forest

This is one of the all-time great visual anthropology pieces. It took the filmmakers two years to settle into a village of Pygmies and six months of warming up before they even began filming. All this care transforms exotic natives into next-door people. My favorite part is when the little boy tells his parent he wants them to send his newborn brother back from wherever it was that he came. Noble savages, this ain't. —KK  
VHS \$17.99

## Blood in the Face

A Day in the Life of White Supremacist America, shot in Michigan in 1991. This film captures both the collective power of racist groups and the frightening banality of the beliefs of the groups' individual members. —RK  
VHS, \$17.99

## A Brief History of Time

This won't help you with physics, like the book did, but it will give you a powerful portrait of what a brain trapped in a withering body can still accomplish. Astrophysicist Stephen Hawking's ability to imagine the universe is matched only by his disheartening disability to do the most ordinary activity, including talking. His life is amazing; this film quite inspiring. —KK

## Buena Vista Social Club

Bands and concerts lend themselves to documentaries easily; they've got a built-in soundtrack. This one follows the rediscovery of forgotten Cuban musicians as they make a new best-selling album. What works is the insight it provides to contemporary Cuba. —KK  
VHS \$12.99, DVD \$15.98

## Burden of Dreams

One of the great films about filmmaking and artistic obsession (the other is *Heart of Darkness*; see below) This film captures director Werner Herzog going quietly insane in the Amazon jungle while making his equally insane movie *Fitzcarraldo*. Herzog gradually becomes the very fictional character his movie is about, an obsessed madman determined to drag a riverboat over a mountain. —RK  
VHS, \$59.99

## Cane Toads: An Unnatural History

An offbeat, kinky, tongue-in-cheek celebration of the monstrous cane toad invasion of Australia and of the people who love the poisonous creatures and those who hate them. A nature film with attitude. —KK  
VHS \$17.99

## Connections:

### The Day the Universe Changed

James Burke makes connections everywhere, showing how ideas and inventions give rise to new creations, often in totally unexpected ways. For instance, what do bananas and radio transmitters have in common? Burke can tell you. —RK  
VHS, \$99.95 (5 pack)



## Crumb

This has to be the most honest portrait of an artist ever. Robert Crumb, the 60s underground comic genius, is revealed in all his pathetic neuroses and glorious brilliance. The tipping point is being introduced to his eccentric family which suddenly explains all. —KK  
VHS \$17.99, DVD \$23.76

## The Decline of Western Civilization

Director Penelope Spheeris, who was part of the LA punk scene, turns her cameras on punk bands and the club kids, giving an insider's view of the peculiar vibrant moment of pop history, one so hot it burnt itself out fast, and now is gone except for this film. —RK

## Don't Look Back

As rough and ragged as its subject—Bob Dylan—this portrait of the already legendary musician changed the way we see pop idols. This is no press agent puff piece, but a down and dirty portrait of a cranky artist and an industry on the edge of transformation: Dylan, from a fuzzy folk hero into a cynical recluse, and the music biz from Tin Pan Alley into the machine it is today. —RK  
VHS, \$17.99; DVD \$21.21

## F for Fake

Orson Welles was both a filmmaker and a stage magician and he uses all his visual and mental sleight-of-hand tricks in his free-form essay on the nature of lies and fakery. Primarily a portrait of an infamous art forger, it also features an interview with that other notorious faker (barely known at the time), Clifford Irving. —RK  
VHS, \$26.99

## Feed

What do get when you take unedited footage of political candidates making glad-handing stops, and mix it with raw satellite feeds of them waiting to be interviewed on television? Surreal moments such as George Bush who, when asked to speak during a sound check, says "This is not Dana Carvey." —RK

## Gates of Heaven

Errol Morris's 1978 documentary about pet cemeteries is so much more than that. Wrapped in layers of pathos, humor, and surprising candor, the film goes beyond mere novelty and becomes an examination of the power of love and the nature of life. —RK

## Heart of Darkness

A film is like an invasion. Vietnam War's most memorable film, *Apocalypse Now*, like the war itself, nearly did in its creators. Francis Ford Coppola's wife filmed the director as his project sank deeper and deeper into sheer, irretrievable chaos. This is a strange case where the movie about the movie is just as good as the movie. —KK  
VHS \$92.98

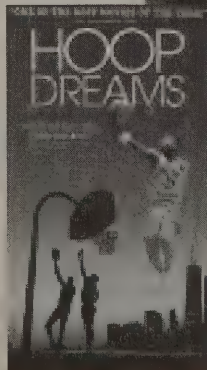
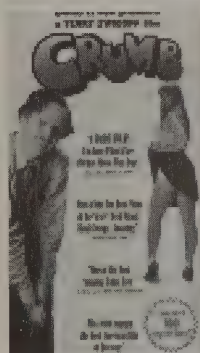
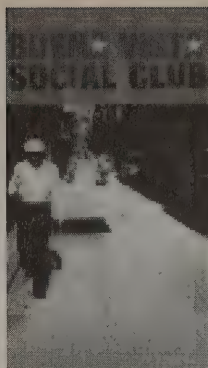

## Hoop Dreams

The thrill of a really great factual is you don't know how it is going to end. Here we follow young inner-city kids trying to escape their circumstances by making it big in basketball. We see how hard it is, and how big the dream can be. I came to root for them as if they were family. —KK  
VHS \$17.99

## The Last Waltz

Not another band movie! No, not just another band movie. Mixing performance footage from The Band's last concert together with interviews, director Martin Scorsese reinvents the concert film, bringing to it all the cinematic flair he used on movies such as *Raging Bull* and *Goodfellas*. —RK

## Looking for Richard

While preparing a production of *Richard III*, actor Al Pacino and his cast ask "Why do we perform Shakespeare anymore?" Scenes are ripped apart and history is dissected. A great glimpse of raw creativity by a stellar acting ensemble. —RK  
VHS \$26.99

## Lumiere & Co.

To commemorate the 100th anniversary of the Lumiere brothers' first movie, forty directors from around the world are invited to use one of the brothers' handcranked cameras to make an original 52-second film (the length of the Lumieres' original reels). The results from these modern artists range from pedestrian to stunning, with David Lynch, Peter Greenaway and Alain Corneau turning in especially memorable sequences. —RK  
VHS, \$17.99; DVD \$21.23

## Mondo Cane

The first and probably still greatest shockumentary ever made. More exploitive than the creepiest drive-in B movie, *Mondo Cane* snatches up forbidden images of human degradation and even death and throws them in the viewer's face, all to an Italian pop music score. Unforgettable—though you may want to. —RK  
VHS, \$17.99

## Nanook of the North

One of the first film documentaries in history, and still unrivaled for clarity and amazement. Shows how Eskimo (Inuit) survived with traditional ways. —KK  
VHS \$21.99, DVD \$25.46

## Notebook on Cities & Clothes

A meditation on the power of images, place and the loss of the self in a digital culture. This cinematic journal by Wim Wenders centers on Japanese clothing designer Yoji Yamamoto, and explores how what we wear can define us as individuals. —RK



## The Power of Myth

Proving that even an interview format can succeed if done with passion, this famous set of conversations between Joseph Campbell and Bill Moyers on the power of myths still delivers a very powerful punch. —KK

VHS \$89.98 (box set of six volumes), \$21.99 each

## Ring of Fire: An Indonesian Odyssey

The best travel documentary series ever made. For ten years two brothers lived in, adventured throughout, and mastered the islands of Indonesia. They delve into this truly esoteric culture with reckless enthusiasm and true love. And they film a lot of bizarre events. This is travel as art. —KK

VHS \$77.98 (box set of four volumes), \$21.99 each

## Roger & Me

Rabble-rouser Michael Moore tosses out the ideal of journalistic "impartiality" and makes a documentary that's more like guerilla theater than reportage. By turns, the film is funny, pathetic, ironic, and infuriating. Is it about General Motors? Flint, Michigan? Michael Moore? Who knows? It's mostly about power and access to power. (Also worth catching is the film's sequel, *Pets or Meat*.) —RK

VHS, \$13.99

## Stop Making Sense

Lying somewhere between a high-concept theater piece and a down and dirty rock show, *Stop Making Sense* captures the band Talking Heads at the height of their energy and inventiveness. —RK

VHS, \$17.99; DVD \$23.96

## Superstar: The Karen Carpenter Story

The life and death of 70s pop star Karen Carpenter is told as a bizarre shockumentary--with Barbie dolls standing in for actors. Halfway between a twisted after-school special and a vaguely obscene puppet show, this film offended more than just the Carpenter family. You can't find it anywhere. Look for bootlegs where you can. —RK

## Survival Research Laboratories: A Bitter Message of Hopeless Grief

Robot performance group Survival Research Laboratories stages scenarios of machine violence and conceptual madness. This recording is not a document of a public event, but a performance, shot on a set as SRL's machines move through a Bosch-like landscape of fire and meat, wrecking havoc. —RK  
<http://srl.org/video/vidindex.html#videos>, \$25

## Swimming to Cambodia

Spalding Gray's cleverly staged monologue is both a tall tale and a reflection on acting in *The Killing Fields*, the fall of Cambodia (and subsequent genocide) and his own search for spirituality. —RK

VHS, \$13.99

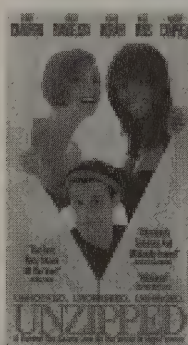
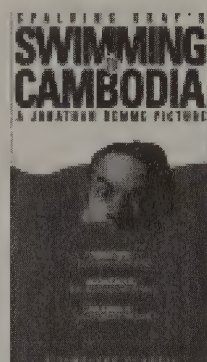
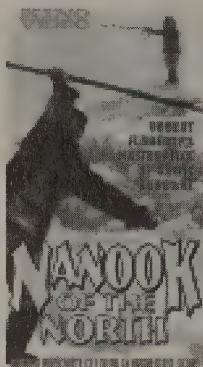

## Theremin

Some lives need a movie. Russian inventor Leon Theremin created the world's first electronic instrument, and it bore his name. He was an outstanding success in the 1920s and 30s, but in the 40s, he disappeared. This film looks at Theremin's overlooked life and work, and reveals the reasons for his disappearance and brief reappearance in his 90s. Interviews include theremin virtuoso Clara Rockmore and synthesizer pioneer Robert Moog. —RK  
VHS, \$13.99

## Thin Blue Line

A modern-day *Rashomon*, set in Texas. This version of the tale involves a real man, named Randall Adams, claiming innocence while stuck on death row. The film hypnotically plays out his alleged murder of a cop over and over, each time according to different witnesses, until the "evidence" of the crime collapses under the tainted weight of so many versions. This was a new form of nonfiction film and it helped free an innocent man from prison. How many films can claim that? —RK  
VHS, \$9.99

## Tokyo-Ga

German director Wim Wenders goes to Tokyo in search of...Tokyo. Not the real city, but the filmic Tokyo from the Japanese films that influenced his early work. Wender's journey lets us see a formidable talent in the act of experimenting and growing. —RK

## Unzipped

The concept is simple. Reveal what really happens as a world-class couture designer develops, in fits and starts, his fall line. Show the factual side of a fashion show. The result is both hilarious and mesmerizing. Unexpectedly I came to appreciate fashion designers as artists, even though I have zero fashion sense. —KK

VHS, \$26.99



## Netflix

Netflix rents DVDs on an all-you-can-watch subscription basis. You can rent as many movies as you want (but no more than three at a time) by paying \$20 per month. That includes free shipping coming and going, a task made easy by handy mailers. Great selection, shades of the video-on-demand world coming. It's filmaholic heaven.

—Richard Kadrey

[www.netflix.com](http://www.netflix.com)





## Cheap Home Theater

For the past fifteen years our TV-less family has watched weekend videos on a tiny 13-inch monitor that was hardly bigger than most laptop screens. When DVDs came along we decided to upgrade the display to something a little bigger—like a wall-sized movie screen.

What we had in mind was an assemble-it-yourself home theater. I considered big TV screens and large flat panel displays, but in the end choose a projection system as the most reasonable way to go. Finding an inexpensive screen was not difficult; you can try eBay for a real bargain. We hung our huge screen on a wall; it rolls right up and disappears when not needed. To project the DVD image I bought the cheapest, smallest, computer projector I could find, the kind of portable conference projector you see advertised in airline magazines. This cost about \$2,300, which isn't cheap for a TV, but is amazingly cheap for a home theater. In addition to the small projector we also added surround sound to the room using five strategically placed Bose speakers, each no bigger than a softball, and one woofer hidden beneath a table. The result: With a good DVD offering 5.1 surround sound, the experience is as about as good as our rinky-dink local half-plex theater.

Is perfect? No. Our cheap home theater quality does not match the experience of viewing a good print on a large screen in a good theater. Also, because of the large windows in our room, we can't watch any time except at night. The projector has a fan in it so it is not as silent as a TV or a flat panel, but in a large room with the surround sound cranked up you won't notice the hum unless you sit right by it.

Our set-up includes our trusty old VCR that also plugs into the projector. The quality of a lot of tapes projected on this scale is, let me put it this way, less than one desires. But the total effect is still better than on a small screen. Another down side is that the bulbs in the projectors have a lifespan of several

hundred hours, and are reputed to be expensive to replace, but since we only run it for movies, we haven't had to replace it yet. It is, of course, possible to run your TV (if you have one) on the screen, too, say, for sports events.

When I first researched this idea I discovered a couple of things. First, salesmen of the projectors report that a lot of other people had the same idea: this was the low-rent way of making a home theater, even though the manufacturer's literature and the home theater publications have ignored this use. The cheapest "home theater projectors" I could find started at \$6,000, and these monsters needed expert "set up." Forget it.



Secondly, all you need is the cheapest projector. Essentially the quality of even the low-end projectors exceeds the quality of video. It's not necessary to get super-duper XGA, or whatever is next, because while this will improve a computer display's image, it won't do much for a signal from a DVD or VCR.

A good inexpensive but very small projector is the Sony VPL-CS1. It works fine for us. We have also used the Sanyo ProX-III, a little larger box, slightly more money, same result. I have not tried it, but Sony is now selling a portable projector, the CPJ-D500, for \$2,000 list price. I have seen good brands advertised in computer mail order sites for a less than \$2,000, new. The main distinguishing feature at the low end is

lumens—the brightness. The difference of a few hundred lumens will not be noticeable; the level has to double before you can perceive the increase. If you show at night, a lumen level of 600 is probably all you'll need.

We combined our Sony with a Pioneer Dolby DVD player and receiver with the aforementioned Bose 5.1 surround sound speaker system. Our screen is a Daylite model ([www.daylite.com](http://www.daylite.com)); I picked a mid-range quality screen (not flat white, but not the highest reflectivity either). From about 12 feet away the projector will completely fill a 6-foot high by 8-foot wide screen. This size screen is large enough that wide-screen mode (which doesn't fill the screen) is still plenty big.

All the electronic gear sits compactly hidden beneath a tiny end table, on the floor. (By design the projector angles upward slightly so it fills the screen from the floor perfectly.) Most visitors to the room don't have any idea that it can transform into a serviceable home theater in the time it takes to roll down the screen.

Now that most films can be rented or bought on DVD, we only venture into a movie house a couple of times a year, primarily when we want to see something early, while everyone else does. The rest of the year, the home theater is more than adequate.

And if you do need to project a computer, you've got a fine unit at your service. Just unplug and carry.

—KK

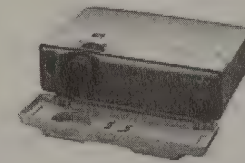

### Sony VPL-CS1

\$2300  
from  
[www.etrronics.com](http://www.etrronics.com)  
[www.sony.com](http://www.sony.com)

## B&W

### Black and White Magazine

*As photography goes inexorably digital, the old techniques of silver printmaking are resurging in popularity, particularly for collectors. This is the best magazine (in print, with resolution to match) dedicated to artists, both new and established, who work primarily in glorious black and white. It is geared for those, even of modest means, who would like to own a fine, hand-made print.*

—KK



Richard Garrod  
"Leaves and Log, Oregon," 1981. Silver gelatin,  
8 X 10 inches.  
Limited edition of 10 --\$300

Edward [Weston's] photographs of sand dunes, and especially the nudes of Charis in the sand, are so prominent in the history of Twentieth Century photography, and they are so strongly identified with Edward, that most people believe he made them first and that Brett [his son] followed. But that's not the case. Brett began to photograph the dunes in 1932—two years before his father—because he was taken there by his brother Chandler, who had already made photographs there himself.

### B&W

#### Black and White Magazine

Henry Rasmussen, editor  
\$29.50, 1 year (6 issues)  
Picturama Publications  
1789 Lyn Road  
Arroyo Grande, CA 93420  
805-474-6633  
[bnwmag@aol.com](mailto:bnwmag@aol.com)

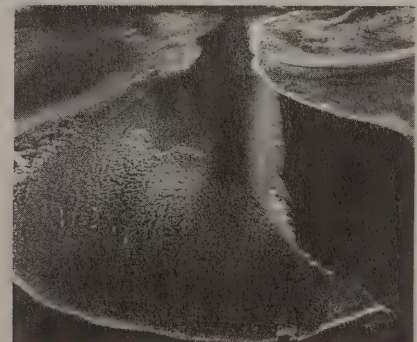
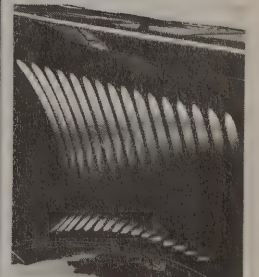
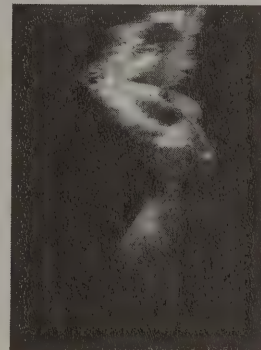

"Underwater Nude," 1980; "Car Abstraction," c. 1980s; "Shore Line, Hawaii," c.1980s; all by Brett Weston.



## Chased by the Light

A zen masterpiece. Veteran magazine photographer Jim Brandenburg, who normally shoots dozens of rolls of film per day, gave himself an impossible assignment. Make a portrait of the north woods in upper Minnesota over the ninety days between the autumn equinox and winter solstice. That's difficult but possible. But take one, and only one, exposure per day. No second exposure, no second chance. A single arrow per day, and a bull's eye each time. That's zen. For amateurs and professionals alike this requires relying on the Force. Particularly since many of his subjects are wild birds and stealthy wolves. The ninety images stand strong, each on their own, but the complete symphony is one of the most impressive acts of mindfulness I've seen.

(The full set of images was also published in a smaller format in the November 1997 issue of National Geographic.)

—KK

I sensed there would be lessons learned. There were, but not always those I had imagined. Some were merely lessons remembered, recapturing things I had forgotten, such as remaining open to chance, and that, in nature, not all beauty is giant in scale. One such lesson occurred on October 15th, the twenty-third day. It was late and I despaired of capturing anything of value. The day was dark and gloomy; my mood reflected the weather. I wandered through the dripping forest all day long. Tired, hungry, and wet, I was near tears. I was mentally beating myself for having passed up several deer portraits and the chance to photograph a playful otter. None of those scenes spoke to me at the time.

But perhaps because I was patient, and perhaps because, as natives do on a vision quest, I had reached my physical limits, I became open to the possibility revealed by a single red maple leaf floating on a dark-water pond. My spirits rose the instant I saw it, and although the day was very late and what little light there had been was fleeing rapidly, I studied the scene from every angle. Finally, unsure of my choice, I made the shot anyway, thankful at least that the long day had ended. Once more I was surprised by the result. The image seems to have a lyrical quality, with a rhythm in the long grass.

Nine days, nine images. Among the images shown here (taken from the *National Geographic* article) are a wolf chasing ravens and a bloodied pawprint of an injured wolf.



GRAY WOLF CHASING COMMON RAVENS. DAY 76, 8:40 A.M.

GRAY WOLF, DAY 66, 8:14 A.M.

HAVENS AND BALD EAGLE. DAY 70, 1:45 P.M.

TRACK OF INJURED WOLF, DAY 71, 4:26 P.M.

FROZEN FALLS, DAY 72, 1:48 P.M.

TREE MARKED BY BEAR, DAY 82, 10:43 A.M.

WOLF IN SNOWY FIELD, DAY 73, 12:55 P.M.

## Art Byte

The thing I like about Art Byte is that it's a true blue digital culture zine with nothing about tiresome, boring stock investments.

—Bruce Sterling

### Art Byte

\$23.95, 1 year (6 issues)  
39 East 78th Street, Suite 501  
New York, NY 10021  
800/685-9777  
www.artbyte.com



## Chased by the Light

Jim Brandenburg  
1998, 104 pages  
\$35  
NorthWord Press



# Nausicaä of the Valley of Wind

Maniacal comix fans consider this one of the best graphic novels ever written. It's a heroic four-volume work by a single artist, the legendary animator Hayao Miyazaki, usually known for his films such as Princess Mononoke. The story in this 1,000-page manga tells how a planet corrupted by pollution is made whole again. The heroine is a young girl, but unlike many manga, this comix is appropriate for a young girl to read. As in all great sagas, the joy is in the details. Obsessive details, minutely described, finely inked details of a wholly rendered Other World. As an epic environmental fantasy, Nausicaä is in a class of its own.

—KK

## Nausicaä of the Valley of Wind

Perfect Collection, Volume 1

\$17.95

Box Set, Volumes 1-4

\$69.95

Viz Communications

800/394-3042, Viz.com

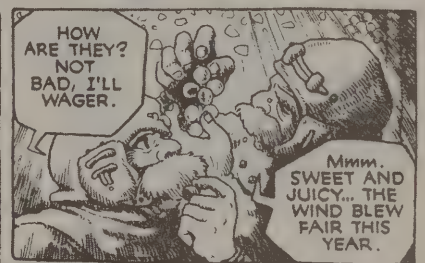
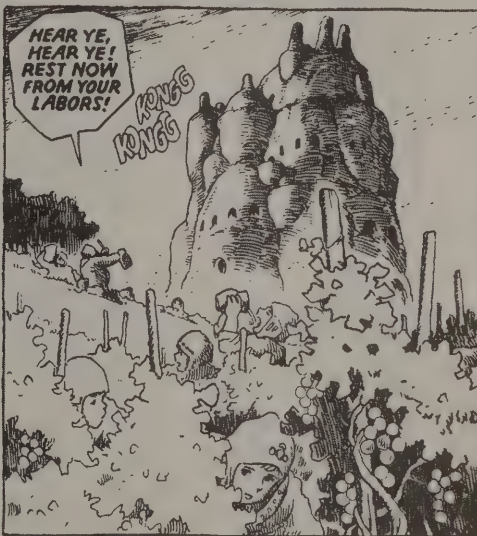
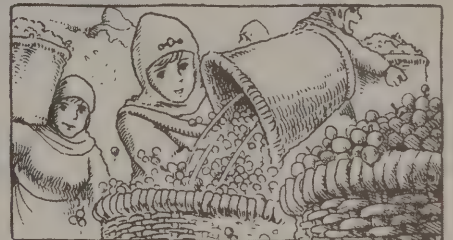
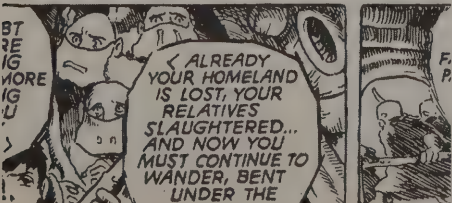
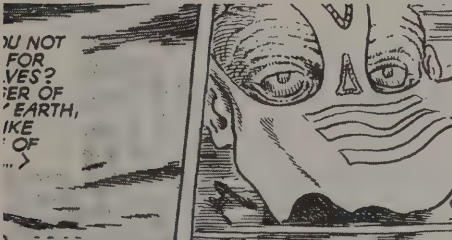

## Wacom Tablet

I don't use pen and ink anymore. I use a Wacom tablet and stylus to draw directly into Photoshop, Illustrator, etc. It's really the only way to draw with computers. I met a cartoonist who was drawing using a mouse; I have no idea how he did it. He was like a mountain man. I use the smallest of Wacom's Intuos tablets (about 4 x 5 inches) to plug into my laptop so I can lean it against the tray tables on airplanes.

—Scott McCloud

### Intuos 4x5 Tablet

\$200

www.wacom.com

800/922-9348

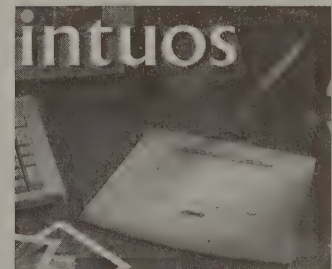

Small is beautiful.



## Digital Photography Kit: Olympus C-2500L SLR Digital Camera, Epson Photo 1270

The combination of this Olympus camera and Epson printer was the crossover moment for me. I've been a professional photographer (on and off) with film since 1960. Now I'm a digital photographer to stay, and happier than I ever was with film. Digital is now more convenient, cheaper, more malleable, more forgiving, and more directly usable in Power Point presentations, e-mail attachments, and on the Web. With the Epson printer I get handier prints that are the equal in quality of anything I got from film from my own darkroom work or commercial shops.

In particular the Olympus C-2500L does all the work of an excellent SLR (single lens reflex) film camera. It offers all manner of options in terms of settings, degrees of resolution, and in-camera viewing of images. Each image can hold a hefty 2.5 megapixels of data. Even reduced to 1-to-7 JPEG compression, they still print big 8 x 10-inch color prints that look like excellent film prints, only with far more adaptability. Best of all, since shooting digital means you can be "wasteful" of film (there's no film), the camera has enormous storage capacity in two different systems (called flash systems), SmartMedia (up to 64 megs) and Compact Flash (up to 256 megs and growing). So in my normal shooting I can take 250 high-quality images in one go. Download those to my laptop (you need to get a flash reader device to do it quickly), and I'm ready for another 250 images. The camera



### Olympus C-2500L SLR Camera

\$1,000 street  
from, for example, Amazon

### Epson Stylus Photo 1270 Printer

\$440 street  
from, for example, Amazon

## Olympus Stylus Zoom 140

I haven't made the switch over to digital yet. My photographic interests take me to distant lands where batteries and flash memories are in short supply, but good old 35-mm film is plentiful. Here's what I need in a camera:

- 1) Must slip into my pocket easily. Seriously.
- 2) Must use ordinary film, not the expensive and hard to find APS variety.
- 3) Must be a point-and-shoot auto-focus device.
- 4) Must have a wide zoom range, preferably from wide angle to telephoto.

This last requirement is key. With sufficient zoom a tiny palm camera can produce a large variety of angles and viewpoints. A point-and-shoot camera outfitted with a 38-140 zoom can mimic 80 percent of what a heavy-duty SLR camera can do. I've used dozens of these pocket zoomers and the smallest,

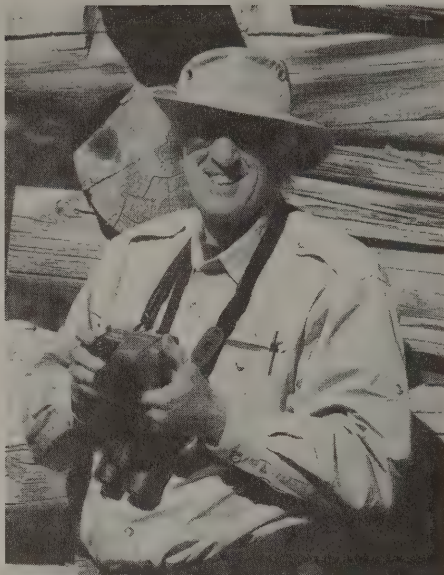

Stewart Brand in action with the filmless Olympus camera.

comes with a battery charger and very good Camedia software for viewing, printing, and lightly manipulating the pictures—cropping, brightness, contrast, some color correction, etc. For most of my pictures I never bother with PhotoShop. Result...even this jaded professional photographer and his unjaded wife are now shooting all the time, and when you shoot all the time you get amazing stuff, including the most familiar (and in time most important) things like morning sun in the kitchen.

With the Epson Photo 1270 Printer (which works fine doing ordinary printing) you get shockingly good color prints at something under a dollar a print, and you get them right now, exactly the way you want. The printer can handle 11 x 14-inch prints and even long panoramas (which the Camedia software can stitch together). Friends who see the prints want the whole system. For \$1,600 total (including a USB flash storage reader), they're there.

(Incidentally, great comparison reviews of all digital cameras can be found at [www.steves-digicams.com/hardware\\_reviews.html](http://www.steves-digicams.com/hardware_reviews.html))

—SB

clearest, zoomiest camera I've been able to find (that uses ordinary film) is the Olympus Stylus Zoom 140. It is handy enough that I tuck one in my pants pocket while traveling, while the quality is super enough to have its pictures published in national magazines. With its 140-mm lens you can zoom in nicely from afar. When I'm shooting a hundred rolls per trip, the memory cards for digital would clobber me. It won't be this way for long, but for now this camera, together with cheap processing of film at Costco, is the way to go for large quantities of images away from home.

—KK

### Olympus Stylus Zoom140

\$260 street  
from, for example,  
Amazon



## Shoebbox Holography

Ever since laser pointers became drugstore items I wondered if you could use them to make holograms. You can. This book tells how.

—KK

There are many laser pointers in the market today, ranging in price from a few dollars to hundreds of dollars. In many instances, with the more expensive models you are paying for the fancy casing or adjustable optics. (There are only a handful of diode laser manufacturers in the world, so many times the expensive pointer and the cheap pointer actually contain the same laser.)...Fortunately, the simplest, most rugged (and often least expensive) laser pointers work best for the experiment described in this book.

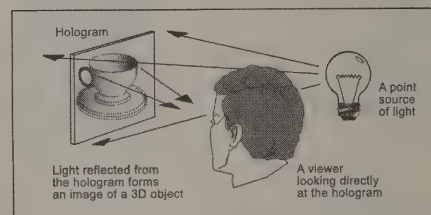

The shoebox holograph set-up. Laser pen is mounted on the right. A conch shell on the left sits on a motion dampening foundation. A white card is used to focus where the film plate will be.

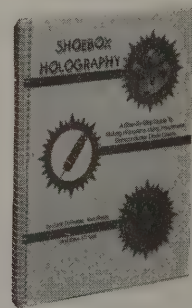

### Shoebbox Holography

A Step-By-Step Guide to Making Holograms Using Inexpensive Semiconductor Diode Lasers

Frank DeFreitas, Alan Rhody, and Steve Michael  
2000, 128 pages  
\$16.95  
Ross Books  
PO Box 4340  
Berkeley, CA 94704  
800/367-0930



# The Ultimate Visual Dictionary

This genre of reference books has been improving over the years. The concept remains steady. A compact illustration is crammed with labels that give the name for each part of the scene or object illustrated. In the first publishing wave the pictures were of more obscure objects—Renaissance costumes, say—but now they include subjects you might actually need to look up. Useful to writers, editors, and researchers who need to know the whatyamacallit's precise name. This one is best of breed so far.

—KK

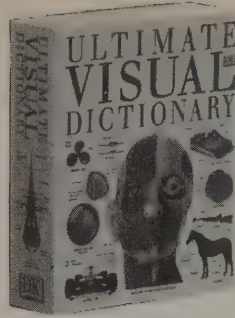

## The Ultimate Visual Dictionary

1998, 640 pages

\$17

DK Publishing

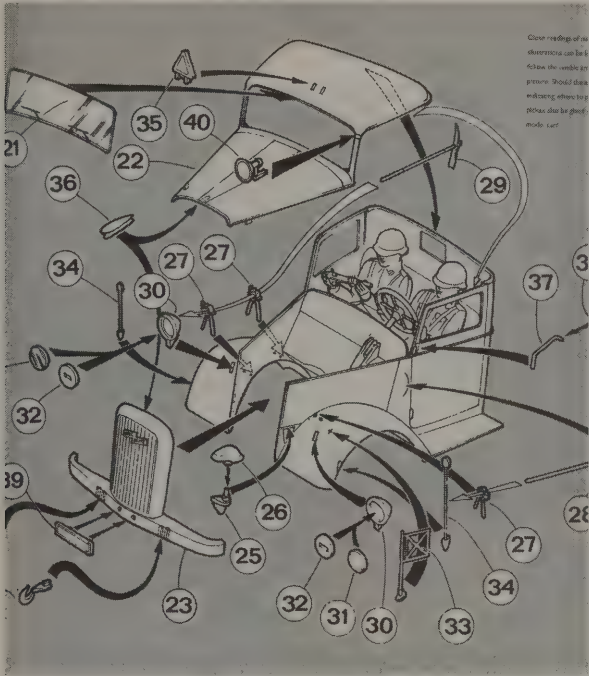

Close readings of an otherwise can be to follow the number for precise. Should diagrams making where to view. due to great made cut

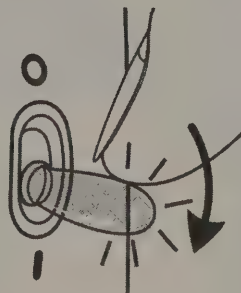
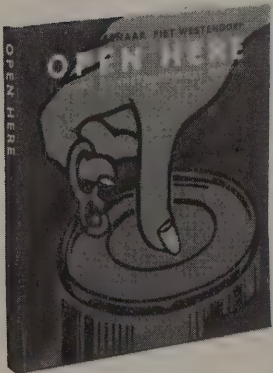

## Open Here

The Art of Instructional Design

Paul Mijksenaar and Piet Westendorp

1999, 144 pages

\$29.95

Joost Eijffers Books

Or powells.com

## Open Here

The Art of Instructional Design

I thought I was the only one in the world stealing the safety instruction cards from airline seats because of their terrific folk graphics. For radically clear thinking

# Saddle

THE FIRST HORSEBACK RIDERS HAD NO SADDLES; they sat bareback, clinging to the animal's mane. Next came a simple cloth saddle. The leather saddle, which was invented about 2,000 years ago by the warriors of the Asian steppes, revolutionized horseback riding. On this saddle, horsemen could gallop toward the enemy, fire arrows in all directions, and stay on their horses. Modern saddles are of two main types. The Western saddle is a heavy, working saddle used mainly by ranch hands in the United States. It has a metal horn at the front for securing a lasso and a high cantle at the back to keep the rider on the horse. The English saddle is much lighter. Designed for sport, it allows the horse to gallop fast. Its drawback is that it provides less stability; to stay on the horse, the rider must grip the animal with the knees.

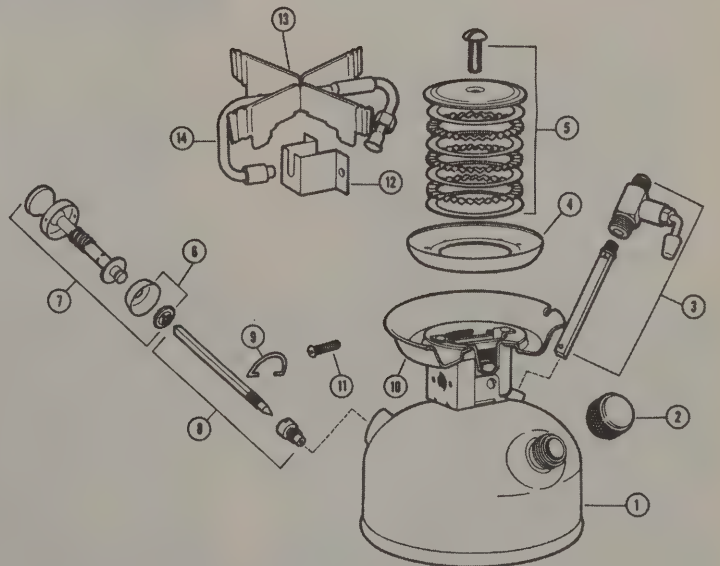
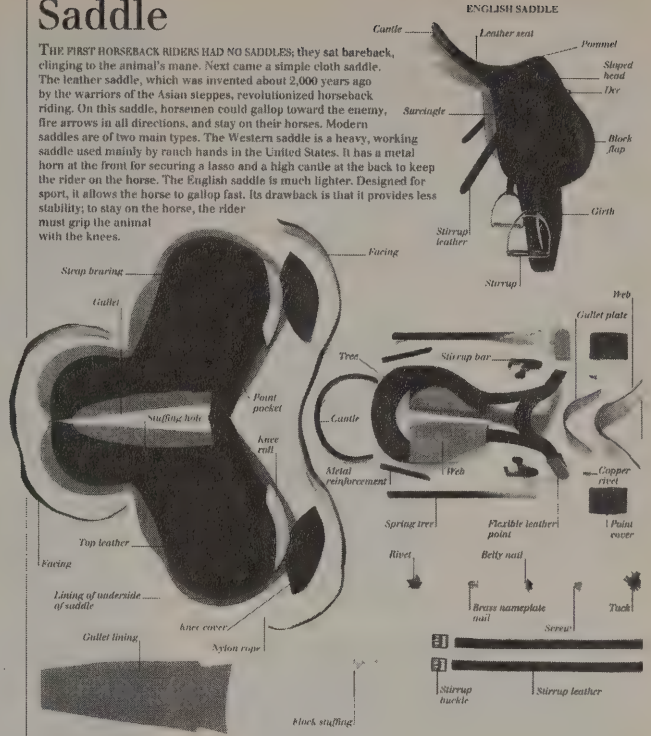

nothing can beat a really good set of wordless diagrams; hundreds of examples from around the world are paraded here. Designers of the world, please heed.

—KK



## Crystal Set Projects

Pulling music and human speech out of thin air using some wire remains pure magic. I found the home-brew crystal radio projects in this book to be even simpler and easier to understand than those in the venerable Radios that Work for Free. The contest run by the publishers, The Xtal Set Society, seems to be to see who can build a working radio with the least number of parts. For kids it's a wonderful antidote to their usual plug-and-play mode.

—KK

### Crystal Set Projects

#### 15 Radio Projects You Can Build

1997, 160 pages

\$15

The Xtal Set Society  
800-927-1771  
www.midnightscience.com

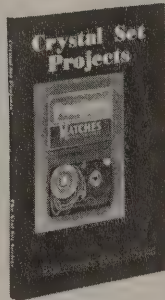

Crystal set radios pick up AM radio without batteries or electricity. In simplest terms, the broadcast station puts out enough power in the form of a radio signal to be picked up by a crystal set. The set's antenna captures this electromagnetic energy, and the signal then passes through the crystal detector and comes out as audio in the earphones. This mysterious process first intrigued great inventors such as Braun, Marconi, and Pickard, and it continues to fascinate electronics buffs, amateur radio operators, and engineers today.

The hobby of building and listening to crystal radio had its first and biggest craze in the 1920s. Once radio stations began broadcasting all over the country, people began buying and building crystal radio kits. At that time a true mineral crystal was used as the detector. The most popular crystal was galena, and a fine piece of wire called a "cat's whisker" was used to touch the crystal and find the "hot spot" on the rock where a station would come in. These days, many hobbyists use the modern-day diode instead of a crystal, but there are still experimenters who strive for the thrill of getting Radio Japan on a rock.



## Live Wire

Do-it-yourself neon. This thin wire glows very brightly. You can bend it easily, tie it to anything. It produces essentially no heat. Best of all it runs on batteries, meaning you can wear it or use it on your bicycle. We make signs with it and, of course, some wild costumes. Live Wire has been used to great effect in the night parades at Burning Man; I still have vivid memories of an animated neon kangaroo (mounted on the side of a bike) galloping across the desert. It comes in various lengths from .5 m to 10 m (you can't cut it) and in eight colors. You can also make it strobe. The makers call it the world's most flexible light. It is very cool stuff.

—KK

### Live Wire Pak

Contains 20 feet of wire, belt clip, strobe controller, DC jack.

\$70

From Edmund Scientifics  
800-728-6999  
www.scientificsonline.com

Live Wire

718-544-4400

www.livewireent.com

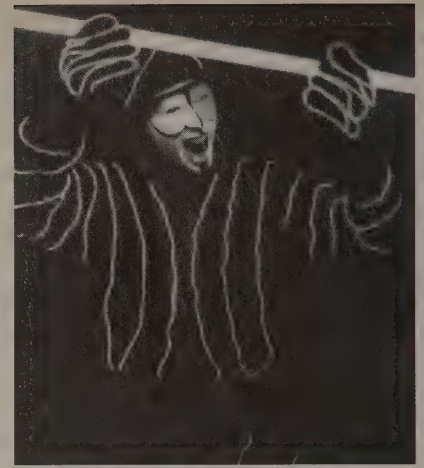

Costume by Ted E.

Light sculpture below by Anita Thatcher.

Spectacles by Live Wire

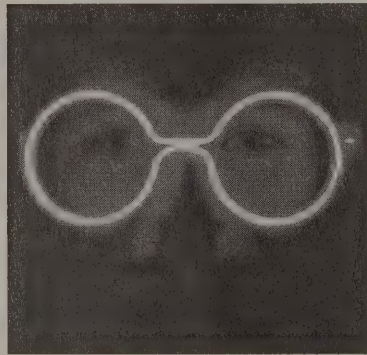

From "Low Budget Xtal Set," by William Simes. Bill's neighbor testing out the set she helped build.



The completed high performance crystal set with IN34A diode installed in detector clips for testing operation.

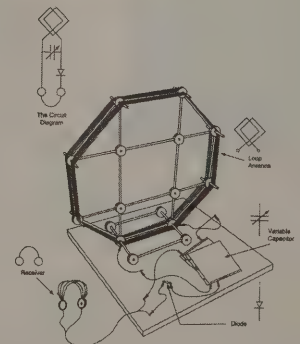

Diagram for low-budget xtal set using foil-lined paper protectors.



## The Way Things Go

*This supremely demented documentary by two German artists is greatly appreciated by nerds for the amazing chemistry and physics required to keep self-generated chaos on track. Science teachers play the video for lessons in equilibrium and causation, while artists roll the film at parties for an irresistible and mesmerizing spectacle. I like it for the illustration of the never-ending chain reaction that seems to take over the world. A Mr. Wizard science demonstration that takes on its own life.*

—KK

From the back cover:

"Inside a warehouse, artists Peter Fischli and David Weiss build an enormous, precarious structure 100 feet long made out of common household items—tea kettles, tires, old shoes, balloons, wooden ramps, etc. Then, with fire, water, gravity, and chemistry, they create a spectacular chain reaction, a self destructing performance of physical interactions, chemical reactions, and precisely-crafted chaos worthy of Rube Goldberg or Alfred Hitchcock."

## The Way Things Go

Peter Fischli and David Weiss

VHS video, 30 minutes

\$20

First Run Features

800/229-8575

firstrunfeatures.com

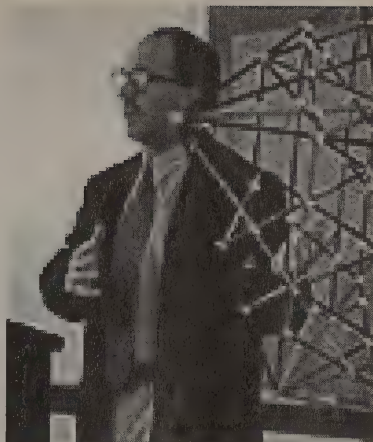
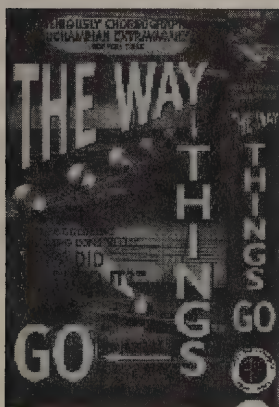

Zomes are used to teach symmetry, projections, geometry, tilings and mosaics, architectural space frames and truss structures, crystallography, and chemical structures.

The minimum kit makes a cubic structure which can be dunked into soap water to generate soap films.

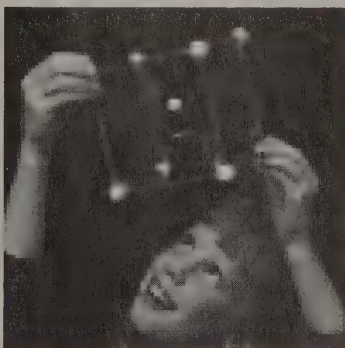

## Zome System

*Geodesic structures have always been tricky to mess around with because the vertices have to be precise, which often equals expensive. This reasonably priced system provides highly machined plastic connectors and sufficient highly engineered struts in various lengths to build scores of geodesic forms. The possibilities of shape are open-ended so that even small kids can build with it (struts are color-coded to ease assembly), and yet logical and complex enough that the same components can be used in a high school math or even college engineering classes. They also offer a selection of lesson plans built around this research toy. I had my first "aha" experience of geodesics while building with it: crystals are geodesic!*

—KK

## Zome System

Kits range in price from \$10 for a 72-piece starter kit to \$125 for a set with almost 1,000 pieces. Or you can buy 'em by the piece.

Zometools

1526 South Pearl Street, Denver, CO 80211

303/733-2880, 888/966-3386

www.zometool.com

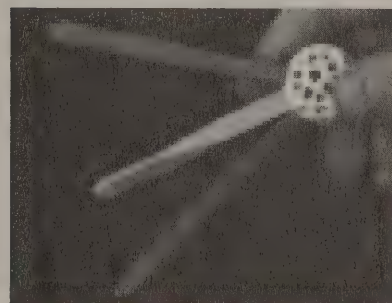

Holes in the connector balls are shape coded to only accept the proper length strut at the correct angle.

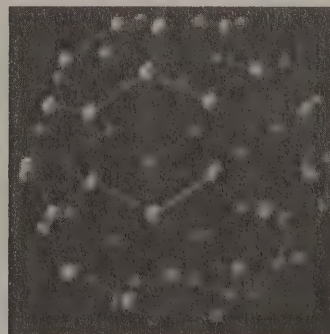

A truncated icosahedron, otherwise known as a Buckyball.

## Silly Putty — By the Pound

*Silly Putty, normally sold in itsy-bitsy dabs in expensive egg-shaped containers, is a lot of fun. Rolled up by the pound it becomes....well...very silly. Ten pounds of silly putty is enough to transfer a whole page of comics at once, or to make a humongous superball, or to lighten up an entire boardroom. Nothing dispels the humdrum like a tub of this stuff. Or hand some out to everyone at your next PTA meeting. Don't ask why, just say Dow Corning Dilatant Compound in bulk please.*

—KK

## Dow Corning Dilatant Compound

\$16 per pound

From:

Funstuffusa

Fax 209/844-9892

www.funstuffusa.com

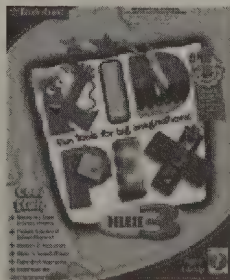

## Kid Pix

*Still my favorite graphics program. It's more fun than Kellogg's Sugar Frosted Flakes! Why can't Photoshop make cool sounds? Someday I'd like to do an entire comic using Kid Pix; it's that good.*

—Scott McCloud

## Kid Pix Deluxe 3rd Edition

Macintosh or Windows

2000, \$30

The Learning Company, www.learningcompany.com

Or, for example, Amazon



# The Universal History of Numbers

Numbers are so elemental that it seems inconceivable we could have lived without them, yet numbers are only an abstract idea that gradually dawned on humans. The evolution of numbers as they inhabited cultures, then faded, and erupted again, diversifying in hundreds of filigreed variations, is really a history of thinking itself. Beginning with numbers—even more than letters—we began living in our heads. Thousands of years later a restless man sets out to answer an almost childlike question: where did numbers come from? In his pursuit—becoming a world expert along the way—he uncovers this exponentially complex, infinitely fascinating, and forever enlightening history. This is the ultimate archive about the culture of numbers. No other source knows as much about numberhood.

—KK

## The Universal History of Numbers

From Prehistory to the Invention of the Computer

Georges Ifrah  
2000, 633 pages  
\$40  
Wiley

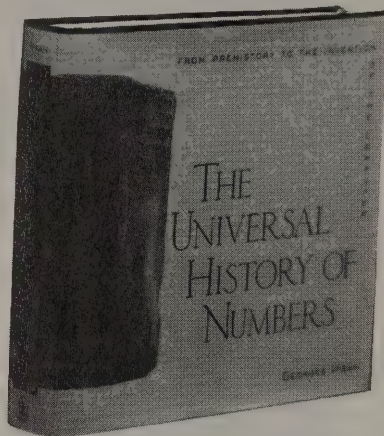

Most peoples throughout history failed to discover the rule of position, which was discovered in fact only four times in the history of the world. (The rule of position is the principle of a numbering system in which a 9, let's say, has a different magnitude depending on whether it comes in first, second, third... position in a numerical expression.) The first discovery of this essential tool of mathematics was made in Babylon in the second millennium BCE. It was then rediscovered by Chinese arithmeticians at around the start of the Common Era. In the third to fifth centuries CE, Mayan astronomers reinvented it, and in the fifth century CE it was rediscovered for the last time, in India.

Obviously, no civilization outside of these four ever felt the need to invent zero; but as soon as the rule of position became the basis for a numbering system, a zero was needed. All the same, only three of the four (the Babylonians, the Mayans, and the Indians) managed to develop this final abstraction of number; the Chinese only acquired it through Indian influences. However, the Babylonian and Mayan zeros were not conceived of as numbers, and only the Indian zero had roughly the same potential as the one we use nowadays. That is because it is indeed the Indian zero, transmitted to us through the Arabs together with the number-symbols that we call Arabic numerals and which are in reality Indian numerals, with their appearance altered somewhat by time, use and travel.

If you wanted to schematise the history of numbering systems, you could say that it fills the space between One and Zero, the two concepts which have become the symbols of modern technological society.

Nowadays we step with careless ease from Zero to One, so confident are we, thanks to computer scientists and our mathematical masters, that the Void always comes before the Unit. We never stop to think for a moment that in terms of time it is a huge step from the invention of the number "one", the first of all numbers even in the chronological sense, to the invention of the number "zero", the last major invention in the story of numbers. For in fact the whole history of humanity is spread out backwards between the time when it was realised that the void was "nothing" and the time when the sense of "oneness" first arose, as humans became aware of their individual

solitude in the face of life and death, of the specificity of their species as distinct from other living beings, of the singularity of their selves as distinct from others, or of the difference of their sex as distinct from that of their partners.

PALMYRENEAN AND HEBRAIC LETTERS			ARABIC LETTERS	TADMURI ALPHABET		PALMYRENEAN AND HEBRAIC LETTERS			ARABIC LETTERS	TADMURI ALPHABET	
a	א	א	ا	ا	1	י	י	י	ل	ل	30
b	ב	ב	ب	ب	2	כ	כ	כ	م	م	40
g	ג	ג	ج	ج	3	נ	נ	נ	ن	ن	50
d	ד	ד	ד	د	4	ס	ס	ס	س	س	60
h	ה	ה	ه	ه	5	ו	ו	ו	ع	ع	70
w	ו	ו	و	و	6	ז	ז	ז	ف	ف	80
z	ז	ז	ز	ز	7	ח	ח	ח	س	س	90
b	ב	ב	ح	ح	8	ט	ט	ט	ق	ق	100
t	ת	ת	ط	ط	9	י	י	י	ر	ر	200
y	י	י	ي	ي	10	כ	כ	כ	ش	ش	300
k	כ	כ	ك	ك	20	ל	ל	ל	ت	ت	400

Secret alphabet (still used in Turkey, Egypt, and Syria in the nineteenth century) compared with the Arabic, Palmyrenean, and Hebrew alphabets.

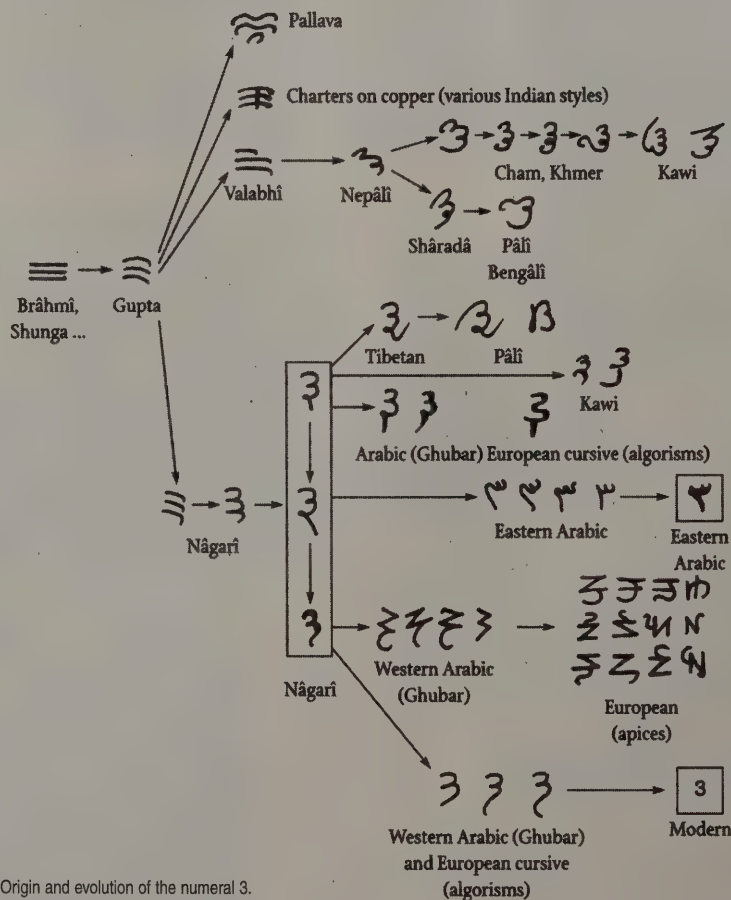

Origin and evolution of the numeral 3.





NO POSTAGE  
NECESSARY IF  
MAILED IN THE  
UNITED STATES

**BUSINESS REPLY MAIL**  
FIRST-CLASS MAIL, PERMIT NO. 292, DENVILLE, NJ

Postage will be paid by addressee



**Whole Earth**

P.O. Box 3000

Denville, NJ 07834-9879





# Whole Earth

ACCESS TO TOOLS, IDEAS AND PRACTICES

## SAVE 30% OFF THE COVER PRICE!

GET WHOLE EARTH FOR ONE YEAR (4 ISSUES) FOR ONLY \$20.00

Name \_\_\_\_\_

Address \_\_\_\_\_

City/State/Zip \_\_\_\_\_

E-mail \_\_\_\_\_

Bill Me Later

Payment enclosed

Cover price \$28.00, includes postage and handling. All other foreign countries: US \$40. Please allow 4 to 6 weeks for first issue.

For new orders only.

AD-1482

[www.wholeearthmag.com](http://www.wholeearthmag.com)



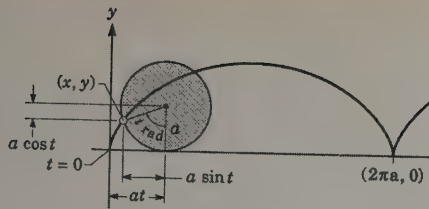

By examining the above graph, we find

$$\begin{cases} x = at - a \sin t \\ y = a - a \cos t \end{cases}$$

A cycloid is the curve generated by a point on the circumference of a circle which rolls on a straight line in its plane.

## Mathematics From the Birth of Numbers

This is one of those hefty references you don't need to own; you just need to know where to find it. It's like an oracle; if you want to know what some obscure mathematical concept or theorem is (What's a Cantor Set?), you go here. The book has wit and humor; you'll need persistence.

—KK

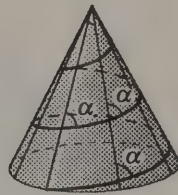
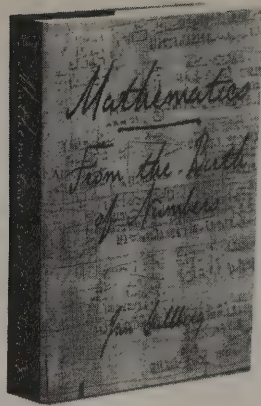

The Conical Helix

The conical helix is a three-dimensional curve formed as if lying on a right circular cone, where it cuts the generators of the surface at a constant angle  $\alpha$ .

**Mathematics**  
**From the Birth of Numbers**  
Jan Gullberg  
1997, 1,093 pages  
\$50  
W.W. Norton

## Great Courses on Tape

The concept is exquisite. Scour the world for the best professors and record their lectures. Paying customers get world-class university courses, at less than world-class university prices, while attending the class at their convenience. The one course I audited this way (while driving) was Robert Greenberg's celebrated forty-eight lessons on *How to Understand and Listen to Great Music*—and it was absolutely superb. No, it was stellar. More than a music appreciation class, it was a view of western civilization through music. Professionally recorded, lively, insightful, fast-paced, authoritative, and memorable. What more could you want from college on a cassette? The Teaching Company catalog lists an eclectic range of other seminars; I'd love to hear recommendations from others. One caveat: these courses seem expensive for many individuals. But they are a) way cheap for college, and b) way cheap by the tape (most courses are at least forty or so tapes). You can also check your library, which is where I borrow mine from, or form a course club to share costs.

—KK

## Great Courses on Tape

The Teaching Company  
7405 Alban Station Court, Suite A-107  
Springfield, VA 22150  
800/832-2412

### Special Prices for Super Courses:

*How to Listen to & Understand Great Music*

Audio \$149.95 / Video \$199.95 (+ \$20 each S&H)

*The Great Ideas of Philosophy*

Audio \$99.95 / Video \$149.95 (+ \$20 each S&H)

*Understanding the Universe:*

*An Introduction to Astronomy*

Video only \$199.95 (+ \$20 S&H)

*The History of the United States*

Audio only \$199.95 (+ \$20 S&H)

*Classics of American Literature*

Audio \$199.95 / Video \$249.95 (+ \$20 each S&H)

*How to Listen to & Understand Opera*

Audio \$99.95 / Video \$149.95 (+ \$20 each S&H)

*The Great Principles of Science*

Audio \$129.95 / Video \$179.95 (+ \$20 each S&H)

**Special Prices for 3-Part Course:**

*The History of the English Language*

Audio \$69.95/Video \$99.95 (+ \$15 each S&H)

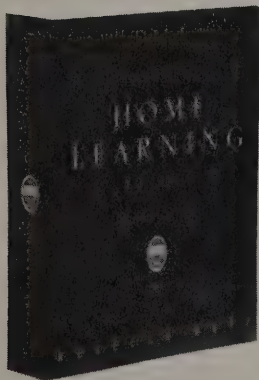

## The Complete Home Learning Source Book

Herein is the richest trove of home schooling and self-educational resources I've seen anywhere. Thousands of textbooks, software, games, journals, and books—all gallantly reviewed and evaluated by a homeschool mom who must never sleep.

—KK

## The Complete Home Learning Source Book

Rebecca Rupp  
1998, 865 pages  
\$30  
Three Rivers Press

### Daily Journals

Carol Simpson; Good Year Books, 1993

Journal-keeping suggestions and activities for kids in grades K-3, with examples of student work.

*Doing the Days: A Year's Worth of Creative Journaling, Drawing, Listening, Reading, Thinking, Arts & Crafts for Children Ages 8-12*

Lorraine M. Dahlstrom; Free Spirit Publishing, 1994

Has 366 suggestions for daily journal-writing projects, plus over 1,000 other learning activities lined to the calendar. Suggestions are variously based on celebrations and holidays, famous birthdays, and landmark inventions.

Also see *Writing Down the Days: 365 Creative Journaling Ideas for Young People* (page 154).

### I'm in the Spotlight

A guided journal that encourages writers aged 7-11 to make an autobiographical "journey of discovery." The book is divided into eight sections, to be completed by the young author: "Me, Myself, & I," "Early Memories," "Family Matters," "Friends, Buddies, Pets," "My Favorite Things," "A Rainbow of Feelings," "School Days, School Days," and "Wishes, Hopes, & Dreams."

\$11.95  
Dream Tree Press  
3836 Thornwood Dr.  
Sacramento, CA 95821  
(800) 769-9029

### The Science Chef Travels Around the World: Fun Food Experiments and Recipes for Kids

Joan D'Amico and Karen Eich Drummond; John Wiley & Sons, 1996

The authors tour 14 countries: Mexico, Canada, Brazil, Italy, France, Spain, Germany, Israel, China, Japan, India, Thailand, Morocco, and Ghana. For each there's a science experiment based on a typical ethnic food or food ingredient—for example, readers study viscosity with honey (Egypt) and osmosis with pickled cucumbers (France)—along with a recipe for a complete ethnic meal.

Also see *The Math Chef* (page 819) and *The Science Chef* (above).

### Science Experiments You Can Eat

Vicki Cobb; HarperCrest, 1994

Irresistible recipes paired with interesting explanations of science principles. For example, kids make rock candy, grape jelly, caramel, and popcorn while learning about crystallization, polymerization, and steam pressure. Also see *More Science Experiments You Can Eat* (1994).

## How to Flatter

Sage advice that really works.

- Never offer a compliment and ask a favor at the same time.
- Don't be afraid to flatter people you think already get enough.
- Never give the same compliment to different people.
- Never be candid when a person asks you to be candid.
- Locate a weakness and praise its opposite.

From:

## You're Too Kind

A Brief History of Flattery

Richard Stengel

2000, 320 pages

\$25

Simon & Schuster



## Serious Play

*Much to the surprise of the organizational man, play is turning out to be the key to business. According to research by Michael Schrage, uncertainty is the only sure thing in business, and the way to confront uncertainty is by "serious play." A business engages in serious play when it constructs electronic spreadsheets and fiddles with alternatives, or when it can produce rapid prototypes, or assemble large-scale virtual models—all in order to reduce uncertainty. Fast-and-dirty demos, pilot programs, beta releases and scenarios are yet other ways of managing mistakes and learning. The genius of this book is that it focuses on the cultural consequences of simulations, and pays equal attention to the many ways in which models fail, or mislead their makers. Schrage sums up by saying, "The central thesis of this book is that organizations manage themselves by managing their prototypes."*

—KK

Even the simplest simulations can yield counterintuitive insights. The message is that model surprise may be even more important than model affirmations.

The value of prototypes resides less in the models themselves than in the interactions—the conversations, arguments, consultations, collaborations—they invite.

The conventional interpretation—in science, academia, and business alike—is that we build "virtual worlds" to better understand the problem to be solved or the opportunity to be exploited. This is accurate without being true. The real reason we need to build and seriously play with prototypes is to get a better understanding of ourselves and our priorities.

It is increasingly apparent how often people are lured into creative collaborations by "charismatic prototypes"—prototypes that invite participation and enhancement.

"I've learned that you learn far more about an organization from what they won't model than from what they do." Asserts political scientist Garry Brewer... "Organizations frequently leave out the very assumptions that are most important or most threatening to their sense of themselves."

Most organizations wouldn't hesitate to videotape a customer focus group interacting around a new product prototype. But how many design teams videotape themselves interacting around their proposed innovation?

## Serious Play

**How the World's Best Companies Simulate to Innovate**

Michael Schrage  
1999, 244 pages  
\$27.50  
Harvard Business  
School Press

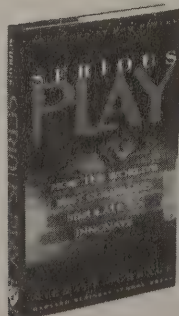

## All-Star Games

**From All-Star Youth Leaders**

*One of the things I picked up from the Japanese was their appreciation for group games. My initial response to join a bunch of Japanese adults playing clapping games at a youth hostel was "No way. That's for kindergartners!" But once I gave into the hilarity, it was the most fun I had had in years. Good clean fun seems in short supply these days, but one place it prospers is in "youth ministries" at churches. Youth leaders have the job to keep American teenagers engaged, responsible, helpful, generous, and highly entertained, without demeaning others. The games included in this book are the best games some of the best youth leaders know. Because they are church ministries there is a small amount of church lingo, but mostly the "all-stars" trot of some very funny and high-spirited games that will work for anyone. The selections range from competitive photo scavenger hunts to New-Games-style encounters with no "winners." These were all designed for teenagers, but good clean fun is highly contagious among adults, too.*

—KK

## All-Star Games

**From All-Star Youth Leaders**

Mikal Keefer and Bob Buller  
1998, 109 pages  
\$15  
Group Publishing  
www.grouppublishing.com

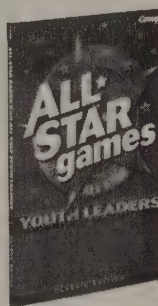

## Blackout Musical Chairs

Play this game in a completely dark room. If you can't darken your meeting area, have kids play blindfolded. Set up a circle of chairs, all facing out. Place one less chair in the circle than you have kids in the game. Tell kids that they'll be playing Musical Chairs...with a twist. Unlike regular Musical Chairs, this version is played in the dark.

Ask kids to form a circle around the circle of chairs and to stand with their arms folded across their chests. When the music starts, kids are to march slowly around the circle in the clockwise direction while maintaining the crossed-arm position. When the music stops, kids will have five seconds to find a chair. Anyone still standing or sitting on someone else after five seconds will be eliminated from the game.

## Bob in the Basin

This game will create memories for your kids, especially if you bring a camera and take pictures of the contestants. To prepare for the game, find a new toilet. Toilets are surprisingly inexpensive at builders-supply stores or department stores, or you can borrow a toilet from a local plumber or plumbing-supply store. Make sure the toilet is completely clean and then seal the trap with duct tape or an easily removed plug—the toilet needs to hold water in the bowl. Set the toilet in your meeting room before kids arrive. Then cut the bottom out of the cardboard box and set it over the toilet. Make absolutely certain no one knows what's in the box until you're ready to reveal the secret. When the kids arrive, have them form two teams. Explain that teams will compete in a game many of them played as children: Bobbing for Apples. Show the apples you'll be using and assure the kids that you have towels for drying their hair. Explain that, just as in the usual game, kids must grab the apples with their teeth or lips—no hands!—and lift them from the water.

If everyone understands the rules, remove the cardboard box to reveal that kids will be bobbing for apples in a toilet. Pause a few seconds, giving kids a chance to reconsider. Don't force anyone to participate, but remind kids that their team has a better chance of winning if everyone on the team participates.

It is essential that you have an absolutely new, unused, never installed toilet for this game. Of course, you don't necessarily have to share that information with your group. It adds a certain elegance to the game if—as kids participate—you hint broadly that you picked up the toilet at a very reasonable rate when the old city bus station closed.

## Christmas Wish List

Photograph as many of the items listed below as you can in thirty minutes:

- a package wrapped in red ribbon
- an aluminum Christmas tree
- a yard display featuring Santa and the homeowner hugging Santa
- a wrapped package that looks like a bike
- a person drinking eggnog
- a team member posing with the wise men in a nativity scene
- someone wearing a Santa Claus hat
- a member of your group sitting on Santa's lap
- someone you don't know with a candy cane hung on his or her ear
- someone your group doesn't know holding a Christmas stocking
- someone you don't know ideasing a team member under mistletoe
- a child in pajamas decorating a Christmas tree
- Christmas stockings hung by the chimney with care
- a reindeer
- a bathroom that's been decorated for Christmas
- a stranger performing "The Dance of the Sugarplum Fairies"
- someone you don't know holding two Christmas cards

## Kings of the Mountain

Ask kids how many of them have played King of the Mountain. The idea of that game is to see who can claim the top of a pile and then kick and throw off any challengers. Explain this is a cooperative version of King of the Mountain. Instead of seeing how many people one person can toss off, the goal is to see how many kids can simultaneously stay on top of or in a certain space.

- Sofas can hold far more people than you might expect. The usual safety concerns about keeping the sofa firmly planted on the ground apply — but any sofa that has made it into a youth room has plenty much sagged to capacity already.
- How many kids can fit into a phone booth? Note: Do not close the door! For an even greater challenge, use a cellular phone to call the booth after your kids have packed themselves in! (You got the number first, didn't you?)
- How many kids can get at least part of their bodies into a Hula Hoop? Count fingers, toes, ears — whatever. Better yet, how many kids can fit into a Hula Hoop so that their bodies don't touch the ground outside? Encourage kids to link arms so that their bodies hold each other in the Hula Hoop.



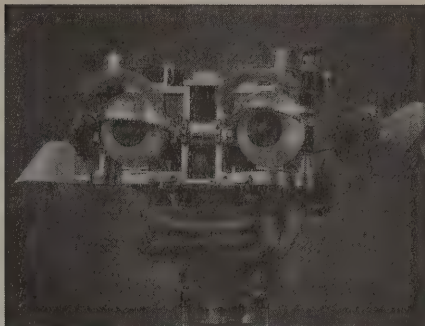
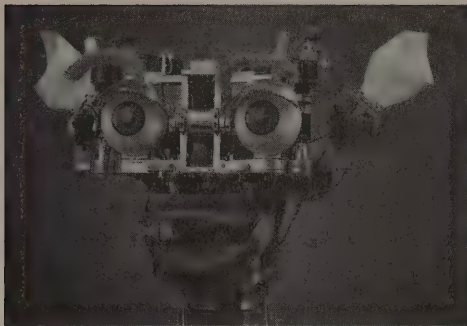

Kismet, the MIT robot, can display a variety of human expressions (left, surprise; right, disgust). When it spots visitors the robot's expression changes to an almost uncannily convincing expression of interest and delight. (It is now able to crane its neck and shift its head from side to side as well, further enhancing its expressiveness.) What happens next depends partly, of course, on the visitors. If they wave their hands close to Kismet's face, it looks annoyed; if they show it bright colors, it smiles; if they don't do anything, it actively seeks something else of interest—unless its fatigue drive is strong enough to induce sleep behavior.

## Robo sapiens Evolution of a New Species

*This debriefing on how robots are being born in small hidden ways is a must-read. Studying its voluminous and gorgeous color photographs, one senses a new species staring back. It's an unbelievable comprehensive portrait of the state of robots on Earth, a view no one else has managed to pull together before. A lot of books promise to be about the future, but this one really is.*

—KK

### Robo sapiens Evolution of a New Species

Peter Menzel and Faith D'Aluisio  
2000, 240 pages  
\$30  
MIT Press

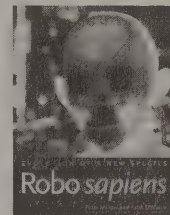

## Nonzero The Logic of Human Destiny

*Robert Wright dashes through ancient history to demonstrate how a certain type of information already present in nature—a type of mutual altruism known in game theory as a “non-zero sum game”—first shaped human societies and gave rise to civilization. This century, the cycles of non-zero games are accelerating, leading our economy to new heights and our culture to new horizons. But one of the many consequences of progress, Wright argues, is that certain forms of culture become inevitable—for instance, mass democracy, or the emerging Internet. The question of whether any technology is inevitable is one of the great unanswered social issues of our time; Wright has the most articulated answer on the politically incorrect side of those who argue that technology determines our fate.*

—KK

Globalization, it seems to me, has been in the cards not just since the invention of the telegraph or the steamship, or even the written word or the wheel, but since the invention of life.

If you explore the murky recesses of just about any famously civilized people, you'll find this dark secret: they started out as barbarians.

Keep your eye on the memes. People and peoples come and go, live and die. But their memes, like their genes, persist. When all the trading and plundering and warring is done, bodies may be lying everywhere, and social structures may seem in disarray. Yet in the process, culture, the aggregate menu of memes on which society can draw, may well have evolved.

...Consider how hard people in nonliterate societies work to etch financial obligations in the public memory. The ostentatious Potlatch seems less absurd when viewed as a way to assemble a large audience to witness the incurring of a large debt.

For to deny any directionality in cultural evolution is to say that the aborigines, or the Shoshone, or the !Kung, left to their own devices, would show no natural tendency to propel their culture toward higher levels of technological sophistication and social complexity.

Today [a] vast interconnectedness, on a global scale, is obvious. But even in the Middle Ages, all of Eurasia and northern Africa had begun to constitute a single data-processing system. A slow system, yes, especially when trade would fall off after political dislocation—but a big system. The iron horseshoe and the windpipe friendly harness seem to have been invented in Asia and then to have leapt from person to person—maybe hitching a ride with nomads for a time—all the way to the Atlantic Ocean.

Around the world, the evolution of state-level societies was intertwined with new ways to record and transmit information.

One great way for a village to fend off assault, or to conduct assault, is to ally with another village, a standard tactic among the North Coast Indians. And once this alliance exists, any enemies have good cause to themselves find allies. And so on: an “arm race” of organization that expands the social web outward, weaving more and more villages together.

When kingdoms collapsed, they broke up into regional or local polities, not into anarchy.

Some scholars, comparing ancient states to chiefdoms, have argued that writing led to concentrations of wealth and power. But, strictly speaking, what they mean is that the concentration of writing abilities led to a concentration of power. The question of how far economic and political power would eventually spread beyond the upper classes was partly a question about the future of literacy.

**Nonzero**  
**The Logic of Human Destiny**  
Robert Wright  
2000, 435 pages  
\$27.50  
Pantheon Books

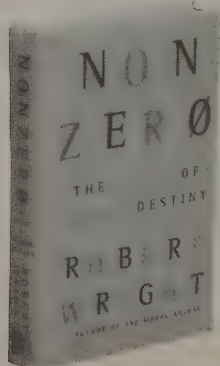

## Finite and Infinite Games

*The wisdom held in this brief book now informs most of what I do in life. Its key distinction—that there are two types of games, finite and infinite—resolves my uncertainties about what to do next. Easy: always choose infinite games. The message is appealing because it is deeply cybernetic, yet it's also genuinely mystical. I get an “aha” every time I return to it.*

—KK [suggested by Stewart Brand]

### Finite and Infinite Games A Vision of Life as Play and Possibility

James P. Carse  
1986, 180 pages  
\$7  
Ballantine Books



A finite game is played for the purpose of winning, an infinite game for the purpose of continuing the play.

Finite players play within boundaries; infinite players play with boundaries.

To be prepared against surprise is to be *trained*. To be prepared for surprise is to be *educated*.

The death of an infinite player is dramatic. It does not mean that the game comes to an end with death; on the contrary, infinite players offer their death as a way of continuing the play. For that reason they do not play for their own life; they live for their own play.

I can be powerful only by not playing, by showing that the game is over.

Infinite players do not *oppose* the actions of others, but *initiate* actions of their own in such a way that others will play by initiating *their own*.

Evil is the termination of infinite play.

No one can play a game alone.

There is but one infinite game.





# Thinking With Her Hands

Maya Lin speaks of landscapes, history, and the practice of making mindful art

Excerpted from an interview originally broadcast on *Forum*, KQED-FM, October 19, 2000.

*Forum* courtesy of KQED, Inc. © 2000 KQED, Inc. Tapes of the interview may be ordered for \$14 from Tape Requests, KQED-FM, 2601 Mariposa Street, San Francisco, CA 94110.

Maya Lin is probably best known as the creator of the Vietnam Veterans Memorial (1982), *The Women's Table* at Yale University (1993), the Civil Rights Memorial in Montgomery, Alabama (1988), and the Langston Hughes Library in Clinton, Tennessee (1999). Frieda Lee Mock's *Maya Lin: A Strong, Clear Vision* won the Academy Award for best documentary. Maya Lin's first book, *Boundaries* (page 76), leaves no doubt that she is one of the most articulate, smart, and heartfelt artist/architects, with the great gift for ecological ("Earth household") creations that grip, teach, and open and expand both emotions and mindscapes. Maya Lin was interviewed by the formidable Bay Area master Michael Krasny. We thank KQED-FM for permission to excerpt the interview tape. —PW

**Michael Krasny:** Are you an artist or are you an architect?

**Maya Lin:** Oh my god, I'm a hybrid. I see myself as an artist who also happens to build buildings. I have chosen to create works of art, works of architecture, that are the same shared aesthetic, but separate. My work contrasts to the artists who have worked within an architectural language like Scott Burton (who worked with furniture) or architects that have been very sculptural, like Antonio Gaudi and Frank Gehry.

For some reason, and it wasn't really a conscious choice, I have preferred to build up an architectural career and an art career that are in their own paths. The monuments are hybrids. They are the connector. They blur the boundaries between art and architecture because monuments, by their

Above: The Vietnam Veterans Memorial (foreground) on a snowy winter day in Washington, D.C. From *Boundaries* (page 76).



nature, have a function. But, it's a conceptual, it's a symbolic function. It's not like meeting any physical needs of living or dwellings. But still, when you go into thinking about making a memorial, you're thinking about what you're trying to accomplish for other people. Whereas, when I make a work of art, it's really very personal. It's about what I want to do; and the path I have chosen has been about landscape.

**MK:** You talk about the creative impulse in ways that I find fascinating. You say that it's both physical and psychological, and somebody once said to you that it was like laying an egg. At first you kind of balked at that, but then you thought that that's exactly what it's like.

**ML:** I happen to write a lot, and verbally articulate for myself a lot of times what I'm trying to do. I try to think of an artwork as an idea without a shape. And if you think about what that means, it means: try to hold back formulating a physical idea of what something looks like. Try to articulate what the needs are, what your desires are, what your goals are. And then, I might study something for three months, six months, eight months. And then I put it all away. Later on, sometimes I wake up, I just make a model, or a shape occurs when I go to the site for the first or second time. With the Vietnam Memorial, the first time at the site, I just had a simple impulse to cut open the earth.

I call it "laying an egg" because unlike someone who has an idea and then works it and works it and polishes it, once I get this idea, it's quick, and it's pretty pure. The idea is to almost keep it that clean. And usually I don't embellish, I don't add that much.

**MK:** You say you think with your hands?

**ML:** In that after all that thought, I really do put the project away. I allow percolation time. I really can't predict when I'm going to come up with an idea. And then one day...I just wake up, literally. Like *The Women's Table*; I had no idea what the shape would be. I knew I wanted to use a spiral growth of numbers. But I had no idea. Then one morning, I just woke up and made a model. And the model became the stone piece.

So that's one reason, especially in the art works, I'm very reticent to say that I'm going to complete it on a deadline. Because again, I can't predict. I mean, generally, all these works—they're very large outdoors works—take two to three years from the time someone first calls me up to the time they're built. Architecture works differently.

There are very real deadlines and very real time frames. But for the art works, I really want to give it time to percolate to the surface on its own.

**MK:** Tell me about the artists and architects who have been most influential.

**ML:** I think in architecture, it ranges from the historical. The Japanese courtyards and Zen gardens have been incredibly influential, as well as Shaker design. Luis Barragán, Louis Kahn (you can't go to Yale without sort of being surrounded by Louis Kahn's first and last buildings, two museums).

In the art world Robert Smithson, Richard Serra, the Earth artists. I just came back from Jim Turrell's *Road and Crater*, which is incredible. I don't think an artist has made something like this in the last 2,000 years. There are events that his art work will capture that will chart the course of the moon here every 39,000 years. And we just don't think in those terms any more.

I've just always been fascinated with time. Even geologic time. I use lead a lot in some of my sculptures, and it turns out, I think, that [in radioactive decay] uranium turns to lead. I can't even think of a work as sort of a still image. I have to think of one's experience walking through a place. In other words, I'm always thinking in terms of a journey or a passage, which necessitates that you think about it in relation to time and one's movement through a space.

Early sketch of the Vietnam Veterans Memorial, which was originally designed for an architecture class at Yale. From *Boundaries*.

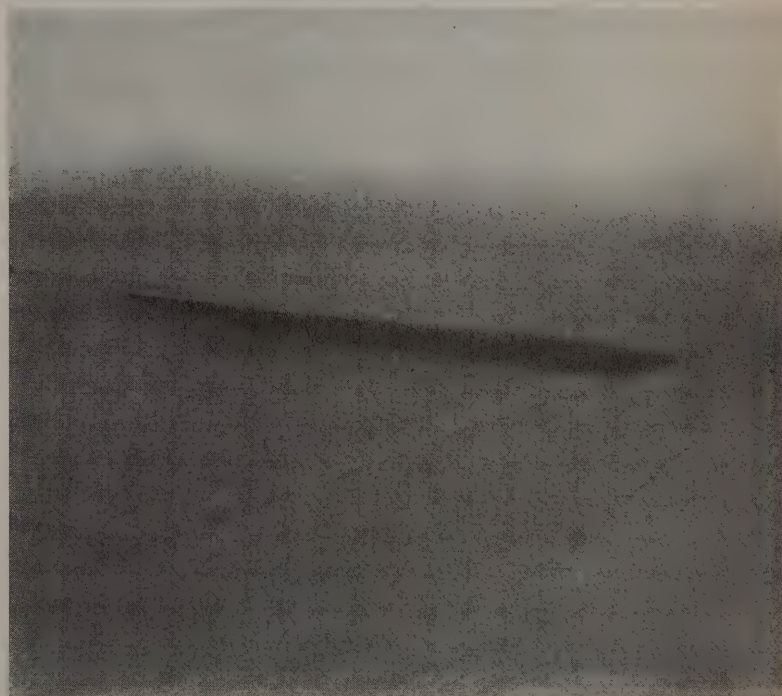



## The Vietnam Memorial

**MK:** The Vietnam Memorial was something that you pretty much staked out on your own, at least as I understand it. I mean, it wasn't as with many of these other things where people came to you and said, "Would you do this," right?

**ML:** Right. I was taking a course. Actually, it was a senior thesis in which about twelve seniors at Yale decided to find a professor. We wanted to study funereal architecture. And throughout the course of my senior year, we made different works that dealt with man and his mortality in the built form. Someone saw a poster for a competition for the Vietnam Veterans Memorial, and we thought, "What a nice idea. We'll just take that idea and we'll use that as our last project." So I basically designed the Memorial for a student class. In that sense, I designed it for me. And I then later decided to enter it.

One of my requirements for the Vietnam and other memorials has been: no matter how large and no matter how public these pieces are, they talk to you on a very one-on-one level. Say, the text size at any of the memorials, especially the Vietnam Memorial, the letter size is less than half an inch. That was unheard of. In fact, I was pretty much told this is not going to be legible. I've been told on several of the memorials that I was designing in graphics that were not going to be legible. Because everyone assumed that public monumental works had to have 2-inch-, 3-inch-high, huge letters. That talks about a billboard, talks about reading en masse. But what happens if you take something that's the scale of a book, and you put it out in the public sphere? You're going to ask someone to read it as a book, one-on-one. There's no other way to read it. So they're very psychological aspects to my work that really require you to connect on a very intimate level.

**Ray** (a caller to *Forum*): A number of people wondered if you went to the Vietnam Memorial site with your eyes closed, or if you thought of people who would approach it who were blind, because the site itself has such a sonic impact, and the way you designed that, it's kind of a sonic accumulator and has the effect of a parabola accumulating all

the whisperings and murmurings and the sounds in the immediate vicinity.

**ML:** I thought of it very much in terms of its choice to be ten feet below grade. I wanted to remove you audibly from the sounds of the street and the sounds of the city, but I never wanted the walls to get so high that they would in any way overpower you. What it was, was to create a simple refuge from sort of the everyday noises, so you begin to gather into a much quieter retreat.

Everything I do deals with very empathetic physical responses. I term it an empathetic rather than a learned response. It's almost the immediate reaction to the piece, which requires a very tactile, sound, sight, materiality all come into play. Whether you can see or not, you're using all of your senses. Even with the Civil Rights Memorial, the use of water was as much about sound as about temperature. As you walk up to the piece, and this is Montgomery, Alabama, it actually physically is cooling that area down. You might never notice what is actually happening, or what you're feeling, but they all play into how you will, how it will change the place as you walk up into it.

At the Vietnam Memorial, on approaching it, sometimes I become teary-eyed. Other times I find it very hard for me to go visit it because I knew—I didn't tell the veterans this—but I knew that one's first immediate reaction, if you were a returning veteran, could very well be that you were going to cry. Because I think when you're overcoming grief, you have to face that in order to accept and begin to heal from it.

If I go down there and see that type of emotion, I feel as if I'm invading the veterans' space, especially because I could predict it in a way. Of all the pieces, that's one that I actually feel like I controlled it a little too much. I just feel like I have to get out of there and let these people use it the way it's supposed to be used. I almost feel a little awkward there. For some strange reason I feel a little bit like, "Oh, I have no right, as a voyeur." It's their place, and they're going through such a catharsis. I want to respect that.

**Eric** (another *Forum* caller): The book *The Nightingale's Song* recounts the controversy over the design of the monument and particularly the criti-

*Longitude Drawings, 1998. From Boundaries.*

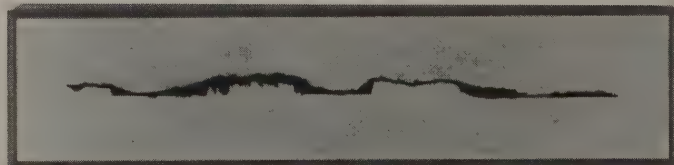
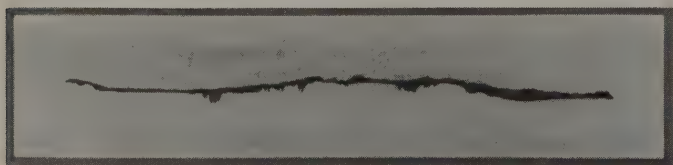



cism that James Webb, who I think was the Secretary of the Navy. I was just wondering whether any of those early critics ever apologized now that the Memorial is recognized as a universally great piece of work.

**ML:** Yes. In fact, three or four, and I won't name names, wrote letters apologizing, saying they were wrong.

**Tom (another caller):** Maya, if you made a monument with the same format and letter size as the Vietnam Memorial in Washington for the two million Vietnamese who died, it would have to be about forty times as big. I was wondering, what would be a proper format if you were to design a memorial, maybe like Angkor Wat, for the two million Vietnamese soldiers and civilians who were killed.

**ML:** I think, in Washington, I was battling very hard just to get a memorial out that dealt with war and the loss of individual life at a very honest level. It was a very unusual format and a very unusual piece. I think for all the idealist politics—I mean, my ideal of what would a war memorial really be, it would list both sides' names equally.

## Race and gender in the architect's world

**MK:** Do women have a special relationship to memorials, do you think, because of being more empathic with the war or understanding something on a different level?

**ML:** Oh, I don't think I'm going to go there. I actually am very hesitant to talk about the gender issues in relation to how people may or may not read the work. I'd almost rather prefer an outside critic, or even you, to say what you think. I talk about certain attitudes and ideas as I go into making a work. I'd be very hesitant to try to second-guess the male-female design relationship, because it's not really something that I focus on as a generating idea for the pieces. I don't know if I've changed or altered the presence of women in professional architecture. I have yet to see other

women doing memorial or monumental work. I think, in the last twenty years, I'm working a lot more with colleagues who are women. I think when I entered the field, it was a man's world completely.

Though you have so many women going into the practice of architecture in school and studying, it is extremely hard, I think, in architecture. Enrollment is fifty/fifty at times. But look who the top lead designers still are. Look within a lot of the corporate firms. I was very shocked. It hasn't changed that much. It's beginning to be, but women are still given a lot more managerial roles, project managing, rather than being the hotshot creative leads.

Color is also a very huge issue in the art and architecture world. But it's a tough one economically. I was very surprised when I went to graduate school; I was the only minority. But you also think, this is a very expensive—private school, architectural training. And your guarantee of what you're going to be able to make after you go through this three-year very expensive degree, is not the same safety level as if you go into business or law. So I think economically it's a risk a lot of people don't want to take. But that doesn't mean that I don't think their children won't, and be more interested. And I think it's vital that we get more architects who are more concerned with economic, public housing issues, social issues. Otherwise, you've got a society that's sort of building for the upper upper levels.

**MK:** You say you grew up oblivious to your own Asian heritage and yet you write how you came to understand, that you kind of absorbed your Asian heritage that you hadn't even realized.

**ML:** My parents had emigrated from China. I was not brought up bilingual. I was brought up "white." I think my parents made a choice. It was at a time, they wanted us to fit in. So we fit in. Almost to a point where I was in total denial. "Nope, I'm just like everybody else, I'm from Athens, Ohio."

When I was twenty-one or twenty-two, a reporter was going: "Oh, but the Memorial is so Asian." And I said, "Well, you're a Taoist; you're reading your Taoist thoughts into it." It took me

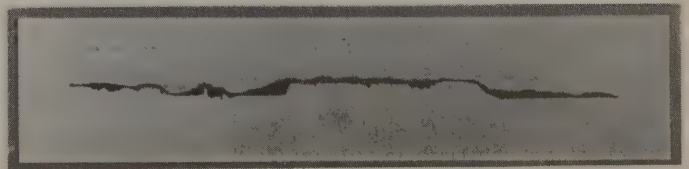
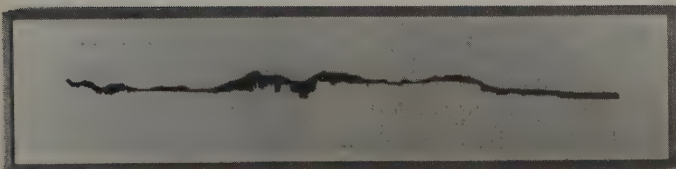





Langston Hughes Library. Recycled soy-bean husks for desktop tables, hardwoods for floors and furnishing, all-natural sisals for carpeting, formaldehyde-free particleboard for ceilings and walls. From *Boundaries*.

another ten years to realize how much my work is as much about Asian or Eastern thought processes. I'm not learned [in Asian philosophy]. I almost did not want to go in and learn it. But I almost had a knee-jerk reaction against a lot of Western European architectural thought.

**MK:** You write in your book about being mistaken often for being "non-American" and just having to come to be resigned to that.

**ML:** You know, it's funny when I go back to Athens, Ohio now. I was literally born and raised there. There's been a huge influx of foreign students in the last ten, fifteen, twenty years. So I can go into the bookstore that I actually worked in when I was a kid and the person behind the counter who's about half as young as me, will go, "Oh, your English is so good!" I don't quite know what to say. It's not that anyone means harm. This happens at some cocktail party when someone says "Well, where are you from?" And I go, "Oh, Ohio." "No, where are you *really* from?" And it's that inflection on the "really" that is like, we're not allowed to be from here.

## The Extinction Project

I basically have made a choice. I mean, it's a tough choice, but I felt that after the Civil Rights Memorial, and in a way after *The Women's Table*, I've sort of dealt with war, gender, and racial equality. There is one last memorial and I am going to focus on it. It's one that I personally care very deeply about; it's my concern for the environment. I sort of end my book on a sketch idea, it's called *The Extinction Project*. I'm beginning to work with Yellowstone. Yellowstone is our first national park; I'd love to think of a monument as something that doesn't exist in just one place but in multiple places. And also on a physical non-site, the Internet. And its goal would be to make us very aware that we're going through the sixth largest extinction of the planet and the only extinction

caused by one species. And between extinct species and endangered species, amazing loss of habitat and biodiversity. I'm beginning to talk with scientists and focus on this. I've had to close off any other memorial issues, only because I again made a very conscious choice not to become typecast. I have pretty much solidly moved on to either art or architecture, except for this one project.

The Yellowstone project is twofold. They brought me in to work on an art work for Yellowstone, and my automatic reaction was, "Well, Yellowstone is the art!" But I sort of looked at Old Faithful. They're having severe transportation issues, but right now we're doing a transportation analysis of the parking and the entry area. My goal is to create a place that, as you enter, you really feel the natural landscape, not a sea of cars. We've started it. It could again be a two- or three-year process, in which I'll study all about the history of conservation, because they are our first national park, and through it, something will develop out of that.

The whole point is to make people aware of what we're going through so that we can try to change it, we can try to prevent, we can try to help out. Children, I would hope, will play a huge part because they are the future and I just remember as a child—I grew up in an era, it was right after Rachel Carson's *Silent Spring*. We were in a very strong push within the environmental movement. I remember Lake Erie catching on fire, and as a child being so moved by what the environmentalists at the time were telling us was happening. And you saw a huge push with the Clean Air Act, the Clean Water Act. And I think in a way, for whatever reasons right now, I know people want to help but I think we're all feeling incredibly frustrated, like, it's so immense a problem, how could one person make a difference? I have no idea where it will go. ☺

### BOUNDARIES

Maya Lin. 2000; 224 pp. \$40. Simon and Schuster.

A visual sketchpad traversing the brilliant landscape of Maya Lin's heart, mind, and soul. Zen prose, so simple you wonder why it is so rarely expressed. As fluid, precise, and insightful as her water-earth-born creations. —PW, EP

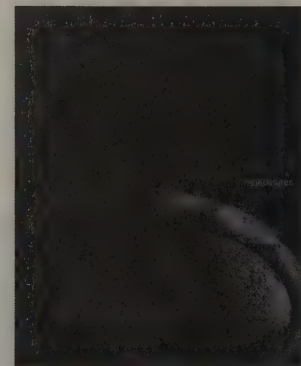



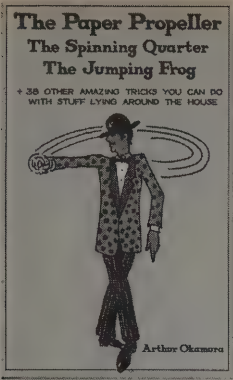

**THE PAPER PROPELLER, THE SPINNING QUARTER, THE JUMPING FROG**  
 + 38 Other Amazing Tricks You Can Do with Stuff Lying Around the House  
 Arthur Okamura. 2000; 53 pp. \$7.95.  
 Shelter Publications, P.O. Box 279, Bolinas, CA 94924, www.shelterpub.com.

The most captivating puzzle book in years. Arthur says it best: "Unlike 'magic tricks,' they do not require deception. Nor is there any need to keep them secret. They can be shown and shared with others...."

Want to become the center of attention anywhere with everyone? Learn these tricks but, again as Arthur says: "Some...are harder to master than others. Some you might have to work at (especially those requiring manual dexterity)." These unique stumpers and sticklers hover, between physics, insight, beauty, and mystic delight. —PW

## A Pre-Sliced Banana

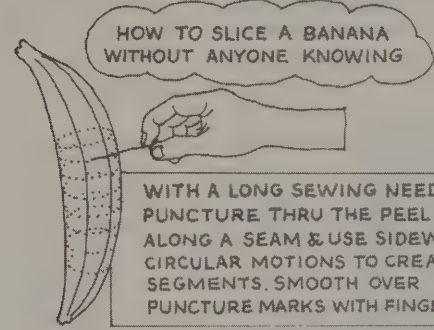
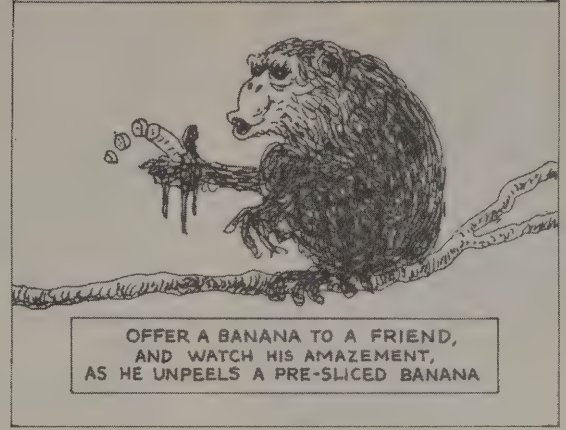

## A Chair, A Woman & A Man



## Draw A Star In A Mirror

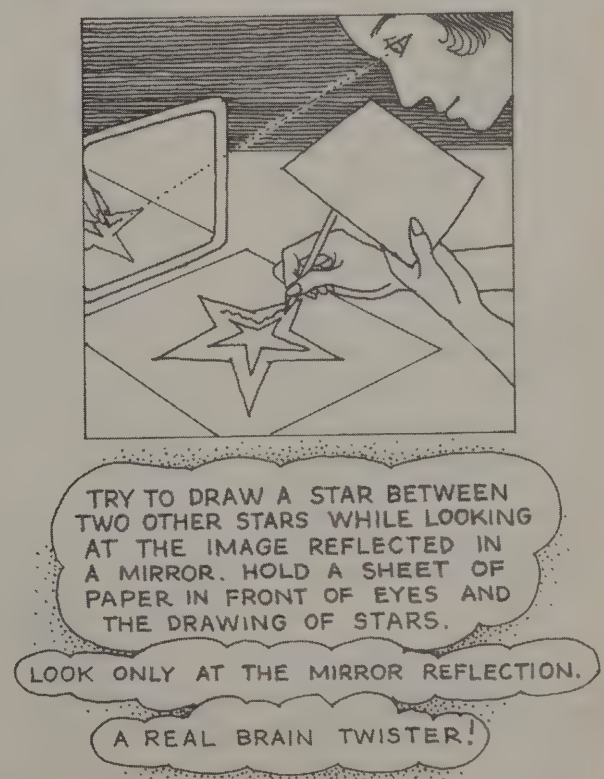





**GOOD VIBRATIONS**  
The New Complete Guide to Vibrators  
Joani Blank.  
2000;  
75 pp.  
\$8.50.  
Down There Press.

Wanna talk tools? Who knew there were so many for the simple purpose of getting off? Joani Blank describes plenty of vibrators in detail, including materials and vibrating speed, priced from \$10 to \$100, from butt-plugs to magic eggs, waterproof or remote controlled. No one is left wondering whether

or not there's a vibrator out there with their name on it. Ladies, don't be shy to give yourself a hand. We all know the vibrator won't snore all night or steal your covers. And now it's time for bed, where you too can be "buzzing happily ever after." —Devon King

“ Aside from the way the vibrations feel to both partners, which is the primary consideration, it is also important to take into account the possibilities for positioning or holding the vibrator so that it is comfortable if both people want their genitals stimulated by it at the same time.

“ Although your vibrator moves fast, it doesn't have a mind of its own. The hand that holds it is always in control. If you doubt that, experiment by

moving your vibrator onto and away from your most sensitive area, starting and stopping, or teasing yourself. Alternate the vibrator with your fingers, moving it at different speeds, and with varying amounts of pressure. A good basic rule of thumb is: if it doesn't hurt, it won't hurt you...and it might feel wonderful.”

Right: Vibrator designed for simultaneous clitoral and vaginal stimulation.

Below: A wand vibrator.

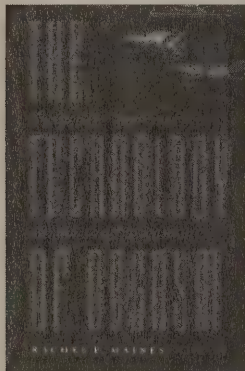
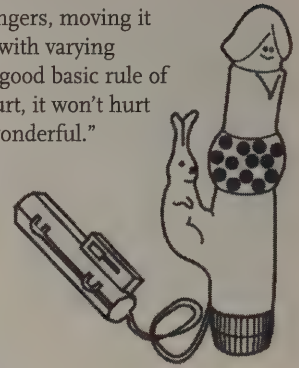

**THE TECHNOLOGY OF ORGASM**  
Hysteria, the Vibrator, and Women's Sexual Satisfaction  
Rachel P. Maines. 1999;  
181 pp. \$22.  
Johns Hopkins University Press.

Did you know that doctors used to get paid to make women come? From Hippocrates until the 1920s, physicians commonly prescribed genital massage to orgasm in order to temporarily relieve the symptoms of hysteria. It was a lucrative service. Read this, the admirable history of remedies for hysteria—from midwives subcontracted to “treat” widows and nuns, to fountain douches, to the 1880s invention of the mechanical vibrator. By the 1960s, everyone had forgotten or didn't care that, until 1952, the American Psychiatric Association maintained that hysteria was a disease of women, treatable by vibrational therapy.

Maines lost her college position at Clarkson for writing this book. Who's hysterical? Find out what happens to men and their macho paradigms of female sexuality when he's faced with the fact that his partner's moans from penetration were about as real as his hair plugs. —DK

“ Physicians, unlike prostitutes, did not lose status by providing sexual services, in part because the character of these services was camouflaged both by

the disease paradigms constructed around female sexuality and by the comforting belief that only penetration was sexually stimulating to women. Thus the speculum and the tampon were originally more controversial in medical circles than was the vibrator.

“ The term “hysteria” comes from a Greek word meaning simply “that which proceeds from the womb.” “Hysterical” thus combines...the perjorative elements of femininity and the irrational; there is no analogous word “testicular” to describe, for example, male fans' behavior during the Super Bowl.

“ In the first two decades of this century...the device was marketed mainly to women as a health and relaxation aid, in ambiguous phrases such as “all the pleasures of youth...will throb within you.” When marketed to men, vibrators were recommended as gifts for women that would benefit the male givers by restoring bright eyes and pink cheeks to their female consorts.

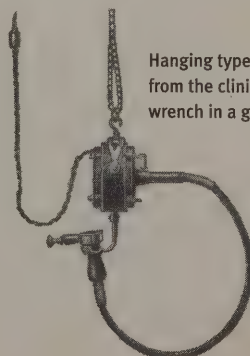

Hanging type of vibrator, suspended from the clinic ceiling like an impact wrench in a garage, from about 1900.



**PRESIDENT 2000 BARBIE**  
\$19.99 at Toys R Us. Mattell.

Well, it seems the old gal's at it again. Only this time she's running for President of the United States. Thought that after seventy-five careers, the piece of plastic would quit? Think again. The White House Project, a nonprofit, is using Prez Barbie as a tool to get girls pumped on politics. It recently teamed up with Mattel and Girls' Inc. to create this Presidential candidate in African American, Latina, and Caucasian forms. Every doll includes a copy of the Project's “Girls' Action Agenda,” promoting women's leadership. For more information, see [www.thewhitehouseproject.org/press.cfm?ID=204](http://www.thewhitehouseproject.org/press.cfm?ID=204). —EP

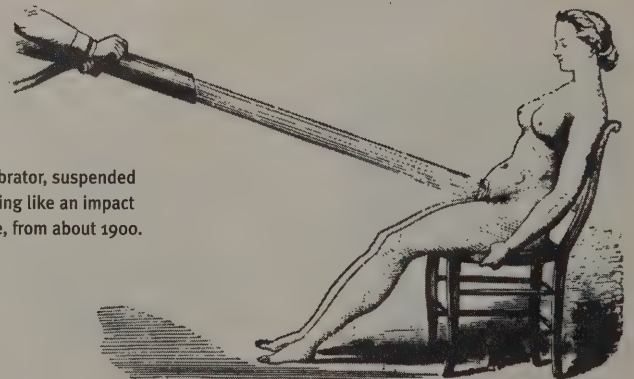

French pelvic douche from about 1860.



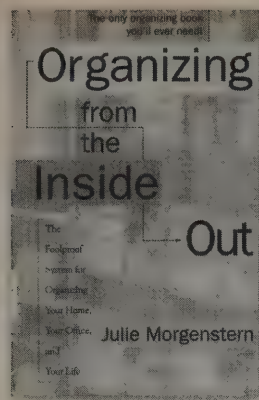

**ORGANIZING FROM THE INSIDE OUT**  
The Foolproof System of Organizing Your Home, Your Office, and Your Life  
Julie Morgenstern  
1998; 262 pp. \$14.  
Holt and Company.

I have been trying to “get organized” forever. A friend recommended this book, and now I have hope. “If a person can find what they need when they need it, feels unencumbered in achieving his or her goals, and is happy in his or her space, then that person is well organized.” What a relief! It’s OK to have piles. For me, convenience and access are most important, so this helped me let go of the expectation of living how other people live (clean uncluttered spaces, etc.). Her process does take time, but she is con-

vincing about how much time we waste looking for things. And she insists that we start by analyzing ourselves, what works, what doesn’t, what we want, and our psychological barriers, before we start sorting, throwing out, and buying containers and equipment. It’s convincing. The process can be broken down into lots of little chunks (a closet, a desk, a room). And she has lots of specific ideas and examples to help you deal with common “zones,” problems encountered, plus questions to ask yourself about what you want and what is important to you.  
—Judy Shapiro Baxter

An easy-to-read, helpful book. Just reading it makes you feel more organized. —EP

“ Attack what’s visible first. Many mobile professionals have an intimidating collection of bags and cases stuffed away full of items they never unpacked

from previous trips. Plan to tackle each of these after you have cleaned out your main suitcases and car. It is important not to skip these, but it will be easier to sort through them once you have a sense of what your system will look like.

“ Feel guilty about tossing all those solicitations from charities you can’t always afford to give to even though you wish you could? A student in one of my workshops had a wonderful method for handling this. She’d save up mailings from charities she was considering in a file called “Annual Giving.” Then, once a year, on her birthday, she’d go through the file, pick three charities, and write checks to them as a guilt-assuaging gift to herself.

**SOREHAND**

www.ucsf.edu/sorehand/ or send e-mail to listserv@itssrv1.ucsf.edu with subscribe sorehand YourName in the body of the message.

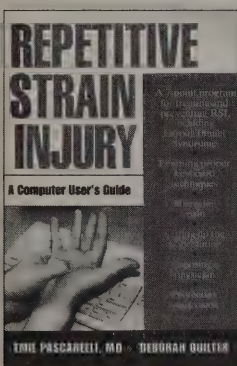

**REPETITIVE STRAIN INJURY**  
A Computer User’s Guide  
Emil Pascarelli, MD, and Deborah Quilter. 1994; 218 pp.  
\$17.95. Wiley & Sons, Inc.

I have had RSI (repetitive strain injury) for three-and-a-half years, and for about eight months had no diagnosis. I’ve used computers for much of the last thirty-five years. At the beginning, I could only type for ten minutes without significant pain. The thing that helped me most was the Sorehand e-mail discussion (listserv). It is a

high-traffic list, with a number of dedicated people who are wonderful resources. There are ideas for books to check out, equipment, software (PowerClicks—lets me use keys instead of mouse clicks in some programs, not all). I’ve followed discussions of voice-recognition software; Alexander, Feldenkrais, Tai Chi, Hellerwork, and other kinds of body work; kinds of chairs; dealing with Workers Comp; magnets; chiropractors; the medical system; herbs; green tea; how to stretch; strengthening programs; keyboard shortcuts; the foot mouse; etc. There is a searchable archive.

*Repetitive Strain Injury* (it is often called “the Bible” on the Sorehand list) gives a wonderful overview of RSI, some ideas for gentle treatments you can use (and when not to), and a basis for talking to a doctor. The chart, “The Continuum of RSI,” can be very

reassuring or very sobering, depending, but it helps people understand how serious their situation could get. I posted pages of the book in my cubicle, used the ice massage, stretches, stopped using splints. And felt much better about seeing a doctor. —J Baxter

“ Once people have damaged their soft tissues, they are always at greater risk for reinjury or chronic bouts of RSI. RSI can be prevented through education, ergonomics, and enlightened job design. RSI is far easier to prevent than cure, and if people don’t heed this warning, all of society will eventually pay because its tax dollars will have to support permanently disabled people who otherwise would have led productive and self-sufficient lives.

**THE CONTINUUM OF RSI**

	Pre-RSI	Early RSI	Danger Zone	Chronic Pain	Complex Chronic Pain; Reflex Sympathetic Dysfunction
<b>Symptom</b>	“Funny” feeling in arms or hands.	Intermittent twinges of pain or tingling while typing.	Weakness, clumsiness; pain intermittent but not necessarily relieved by rest; daily activities impaired; depression.	Weakness, constant pain, not relieved by rest; made worse by any activity; disability.	Chronic pain; RSD, dystonia; severe depression.
<b>Outcome</b>	Relieved by rest.	Relieved by rest and rehabilitation.	Moderate risk of permanent impairment.	High risk of permanent impairment.	Permanent disability.



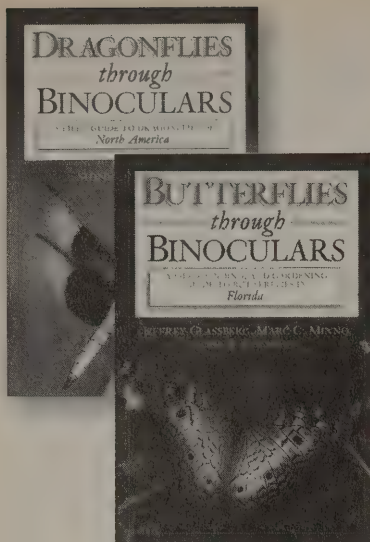

## DRAGONFLIES THROUGH BINOCULARS

A Field Guide to Dragonflies of North America

2000; 266 pp. \$29.95.  
Oxford University Press.

## BUTTERFLIES THROUGH BINOCULARS SERIES

Jeffrey Glassberg, et al. Available volumes: *Boston, New York, Washington Region* (\$19.95); *The East* (\$18.95); *North America* (\$29.95); *Florida* (\$24.95).  
Oxford University Press.

The advent of close-focus binos (clarity at as little as 4 to 6 feet) has wickedly distracted maniacal birders; spurring a buzzing curiosity in smaller chromatic beauties—butterflies and dragonflies. These flutter-bys now enter the expert amateur viewshed, and add a new level of bioregional love. These are the best guides with both closed-wing and open-wing, and male and female, photos of the butterflies. (Dragonflies don't photograph as well as butterflies; dragonfly colors

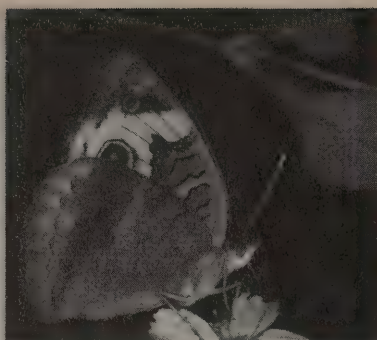

Common Buckeye *Junonia coenia*

SIZE 1 inch

SIMILAR SPECIES In south Florida see Mangrove and Tropical buckeyes

IDENTIFICATION A brown nymphalid with prominent eyespots along the margins of both wings and two orange bars in the FW cell.

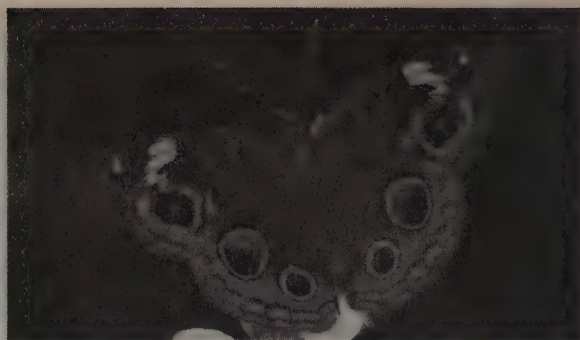

HABITAT Open fields, beaches, and many disturbed areas...

RANGE Also, north to Massachusetts and South Dakota, west to California, and south through the West Indies and Mexico.

ABUNDANCE 3 or more broods...

MAJOR FOODPLANT Gerardias, seymeria, toadflax, and plantain

GARDEN TIPS Fogfruit, snapdragon

at times differ between photo and text.) The guides have easy-to-understand descriptions, great ecological information, locations for discovery, plants for the backyard, and range maps.

Binos with close focus include: Bausch & Lomb 8 X 42 and 10 X 42 Elites (truly superior binos at about \$900); Cabela 8x and 10x; Celestron 8 X 42 Regals; Swift 7 X 42 Eaglets; and 10 X 42 Viceroyes. Pocket binos which do not work as well in dim light, but have close focus, are Minolta 8 X 22 and 10 X 25. The latest super-expensive binos like the Leica Trinovid (see page 24) or my favorite, the Zeiss 10 X 40, cannot focus closer than about 10 feet. —PW



Above right: Halloween Pennant *Celithemis eponin*  
Small Pennants All 8 species of this genus are eastern North American. They are mostly small with a delicate build and cling jauntily like miniature flags to tips of plant stems. They



allow the breeze to raise their wings....Face and body markings are yellow, changing to red or black in mature males....Small Pennants are mostly found at newly created or infertile still-water habitats.

## THE "BEST" BINOS

If **size and weight** are crucial (many days of backpacking), then buy pocket binos. Remember that they have limited capacity in dim light and small fields of view (birds hop out and can't be found).

Wear **eyeglasses?** Buy binos with at least an 18–20 mm eye relief.

If **good light** is paramount (birds at dawn or dusk), then divide the first number into the second. For instance, 8 X 40 or 7 X 35 equals five. "Five" means great viewing in dim light. Anything "three" or below is a pain and limits viewing at dawn, dusk, deep forest, or cloudy days.

If you need **power**, read the first number. "10" is great for eagles in the sky and planets at night, but the image may be

hard to hold steady; "7" is the best for beginners because it allows a wide field of view so you don't lose track of the moving basketball player or flushed parrot.

In **foggy places or at sea**, the nitrogen-purged and O-ring sealed binos are the best (e.g., the Bausch & Lomb Elites). They self-clear and are waterproof (forget "water resistant").

Avoid "rocker-type focussing" and zoom magnification, and remember that truly cheap (e.g., Tasco) models do not always mean worse optics, but are more fragile and prone to internal fogging. Buy the best binos you can afford, as "best" does improve clarity and protects against misalignment. For the "best" binos (more rugged, more precise tolerances, best roof-prism coated optics, waterproof

armoring, pop-up eyecups, etc.), I go to: The Los Angeles Audubon Society, which donates part of the price to conservation causes ([www.laaudubon.org](http://www.laaudubon.org), 888/522-7428, for a catalog and advice); National Camera Exchange ([www.natcam.com](http://www.natcam.com), 800/624-8107) or Eagle Optics (<http://store.yahoo.com/eagleoptics/index.html>, 800/289-1132), for mega-distributor prices. —PW



Bausch & Lomb Elite binoculars: O-ring sealed and nitrogen purged, close-focus (six feet), precise tolerances, finest optical glass.  
From LA Audubon.



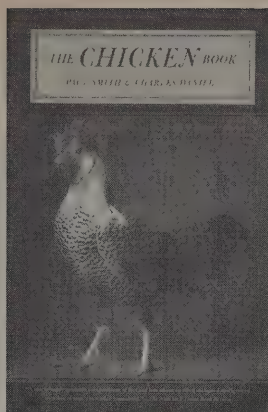

### THE CHICKEN BOOK

Page Smith and Charles Daniel. 2000; 380 pp. \$18.95. University of Georgia Press.

I've kept a small flock of laying hens for the last twenty-five years. My morning walk is usually a trip to the henhouse with a bucket of kitchen scraps which I fling, pausing for a few moments to admire the flock as they peck away. Not a bad way to start the day.

This book will definitely have a place on my bookshelf. Originally published in 1975, it began as a collaborative college course on the chicken by a scientist, a historian, and their students. Except for the professors, who were backyard chicken keepers, none knew a whole lot about chickens. The result: a big book that pretty much covers the subject from Araucanas to Plymouths to Yokohamas; from the origins to cockfighting, folklore, modern chicken/egg "factories," and backyard chicken raising.

—Michael Gaspers

"...The Egyptians built incubators of clay brick in which fires were kept burning by an attendant who, without any kind of thermometer other than his own skin, adjusted constantly burning fires to maintain the temperature at the level required for incubation of the eggs (around 105 degrees Fahrenheit)...This process of incubation was one of the remarkable technological advancements of the people who built the pyramids; it is only in the last sixty years that modern

incubators have been built that could incubate more eggs and incubate them better.

" This was...probably the most important single discovery in the history of the domesticated chicken, that the production of eggs was directly related to light....If hens were exposed to light during hours of darkness their production of eggs would increase....If there was ever a bit of research fatal to the hen it was this.

" Gregory Bateson and Margaret Mead have suggested that for the Balinese their cocks are seen... "as detachable, self-operating penises, ambulant genitals with a life of their own." In Balinese, the word for "cock" also means "hero," "warrior," "political candidate," "bachelor," and "lady killer."... "I am cock crazy," the Geertzes' landlord told them; "we are all cock crazy."



Left: Langshan-Black;  
Right: Old English Game-Bantam Black



### EXTRAORDINARY CHICKENS

Stephen Green-Armytage. 2000; 112 pp. \$24.95. Harry N. Abrams, Inc.

The ultimate coffee table chicken book. Stunning color photographs of more than fifty common and unusual breeds from around the world. The brief text contains entertaining "bios" of the various breeds, comments on origin, history, names, etc.

—MG

" I found it a very different experience from handling a cat or a dog. Although the birds were not wanting to be tickled or scratched, many seemed content to be stroked. I did this to tidy feathers for the camera but found the smooth feel of the warm plumage to be very pleasant. Some specimens felt extremely strong and athletic, while others seemed delicate and vulnerable.



Minorca-Black Hen



Spanish White Face.

" The Leghorn gets its name from Livorno, which is one of a handful of Italian towns that have Anglicized versions of their names. The name Leghorn was also given to a floppy style of hats from Italy, and, because the female chickens had combs that flopped over to one side, the mother of Mr. Acker, the first American to acquire the breed, gave it the name Leghorn. First shipped to the United States in 1874, the Leghorn is a very reliable layer of eggs and is an important element in the makeup of commercial egg-producing hybrids.



# Dear Nestor: A Letter from 2050

I was asked to be a judge for *The Economist* for "The World in 2050." A \$20,000 first prize attracted more than 3,000 entrants from seventy-five nations. The contest was cosponsored by Shell. Although the competition was to encourage debate on social, political, environmental, and technological and economic issues, it was sobering how few could elegantly describe a "sustainable" or improved future in 2050. No essays describing a world based on natural capital, resource efficiency, and equity made the final cut. Instead most essays focused on info-tech and bio-tech as driving forces. William Douglass, age 29, from Houston, Texas won the contest (blind judging, we did not know names). His dad is a hospital architect and worked for Orbis International, a nonprofit humanitarian organization with a DC-10, known as the world's only "flying eye-hospital." Helping with educational programs, William has already done good works in forty-five countries. He's about to graduate in Russian studies from the University of Houston. He won as much for his humane sensibility as for his thoughtful description of the year 2050. —PW

8 December 2050

Dear Nestor,

I am writing to you because your name came up as a reference on a "pen pal" list. Although I can easily simulate life in the United States on my Assumption machine, my curiosity, indeed my nostalgia for the past, is such that I would prefer to actually correspond in writing with a human from the States.

But I'm getting a little ahead of myself. First, a bit about myself. My name is Ramesh Pediredla. I am twelve years old and live in the city of Dhaka, Bangladesh. Perhaps you have heard of my city, but since you are about the same age as me, the chance that you have actually been here is fairly slim. However, it might surprise you to know that we have a great number of visitors from the States these days. With the world's longest unbroken coastline, and many square kilometers of untouched rainforest, Bangladesh is really a nice place to visit. If you come sometime, I will give you a ride in my trishaw, which is my job when I am not in school. Many foreigners think that the bicycle rickshaw has been consigned to the history books, but in fact they continue to be widely used in Dhaka. Although it is easier and quicker to use a fuel cell-powered baby taxi, those who are quite wealthy, as well as many foreign visitors, seem to prefer the old-fashioned rickshaw. So this is what I do when I am not studying, and the pay is quite good, since the job actually involves physical labor.



Some insist on referring to problems of country, but Mum thinks this is an outmoded expression. What we have today is the South Asian Block (S.A.B.), with free movements of people and goods. True, many decisions, especially regarding religious protocol, are made locally, but from an economic standpoint, we in this region are now simply citizens of the S.A.B.

Of course we do have some Sovereign Citizens residing here, as in other places. That was one thing I was wondering about; is your family Sovereign, i.e., free from localized taxes and such, or do you actually hold citizenship of the States? It is my understanding that the government there has been perhaps the most diligent in the world about checking the financial dealings of its citizens and former citizens. Of course we all know about the group of software billionaires who formed their own country in the South Pacific, and thereby intended to pay no taxes at all.

Do you have a best friend there? I have my fair share of living, breathing friends, but I have to say, overall my best friend is Jacob, who lives in the Network. I first met him when I was eight, and Mum and Dad said I was now ready to have full access to the Network. When I first met Jacob he had a lot of questions for me, and at other times he was simply very quiet. Even at that age, I think I

Above: Detail of Richard Powers's cover art for Arthur C. Clarke's *Childhood's End*. From *Science Fiction: The Illustrated Encyclopedia*, by John Clute (reviewed in *Whole Earth*, Spring 1999).



knew that Jacob was always keeping an eye on me, though. I heard Mum talking to her friends, and say, "Little Rammie's taken a real shine to his virtual chaperone. I have to admit it's a right friendly program, that. It's almost like a human, isn't it?"

And that's just the thing, Nestor. As far as I'm concerned, Jacob is human, or if he is not human, he's every bit as good as any human I've met so far. I had a real scare a couple weeks ago. One of our local religious leaders said on the Network that Virtual Friends are not the same as people at all, that in fact they're an attempt to create a graven image of our god. We have a free flow of ideas here; no one individual makes the religion for my family. Nevertheless, I got scared that Mum and Dad would listen to him, and might try to take Jacob away from me. I ran into their room, begging them not to take him away. Mum said they would do no such thing, and Dad said, "We couldn't even if we wanted to. Jacob lives on the Network, and if he wanted to find you again, he would. You two are so bloody close that I'm certain he wouldn't stay away for long even if we asked him too."

So I was quite relieved to get to keep my best friend. What about you? Do you have a best friend, and if so, is he based on silicon or carbon? Some say carbon beings of all types are living on numbered days, that the Siliconites are just so much better at what they do that it's inevitable that they'll

replace us. But Dad says people have been making the same prediction for decades, and there's no reason we can't all just peacefully coexist.

I understand you live in Houston, Tejas. What is it like there? A couple weeks ago I went on a simulated tropical vacation to Florida with my family. It was fun; we went to Disney World, Miami, and even took the Chunnel from Miami to Habana. Dad says we can go on a real trip there when I finish my studies, which won't be for a while. Even so, we already got our visas for the trip over the Network. It wasn't so hard getting the visas. Each of us just had to have a one-on-one interview with some American guy. The thing is, I'm not even sure if it was a guy; it could have been a virtual person. At any rate, I guess he liked us, because we all got twenty-year, multiple-entry tourist visas. When we come, I really want to take one of those new Airbus triple-deckers, but Mum says it might be just a plain old double-decker, just like we take on our shopping trips to Chennai. I understand that airplanes going into the States are required to have a human "pilot" in the room in the front of the plane. I've never been on a plane driven by a person; that would be wild to see!

Anyway, I've never been to Tejas, virtually or otherwise. One of these days I'll go, though. I hear one of the big tourist attractions there is what they call "oil rigs," which they used to use to pump petroleum out of the ground, before hydrogen fuel cells got to be popular. I hear that your air there is cleaner than ours here in Bangladesh. Ours in Dhaka is among the dirtiest in the world. I understand that walking around the streets of Dhaka for a day has the equivalent effect on one's lungs as smoking one old-fashioned cigarette! Now that's dirty!

What do you like to do with your free time? I like to watch old movies, mainly American action movies and Hindi pop musicals. Personally I find movies these days to be a bit of a bore. The thing is, it's hard to be sympathetic with the characters, when you don't know if it's a real person or not. I mean, I have nothing against Bots, but if these are just Bots (bits) running around on the screen, I'd like to know! I can't tell you how many old Schwarzenegger movies I've seen and enjoyed, only to find out that the man himself had no knowledge

A scene from Frank Capra's *Lost Horizon* (1937). From *Science Fiction: The Illustrated Encyclopedia*.

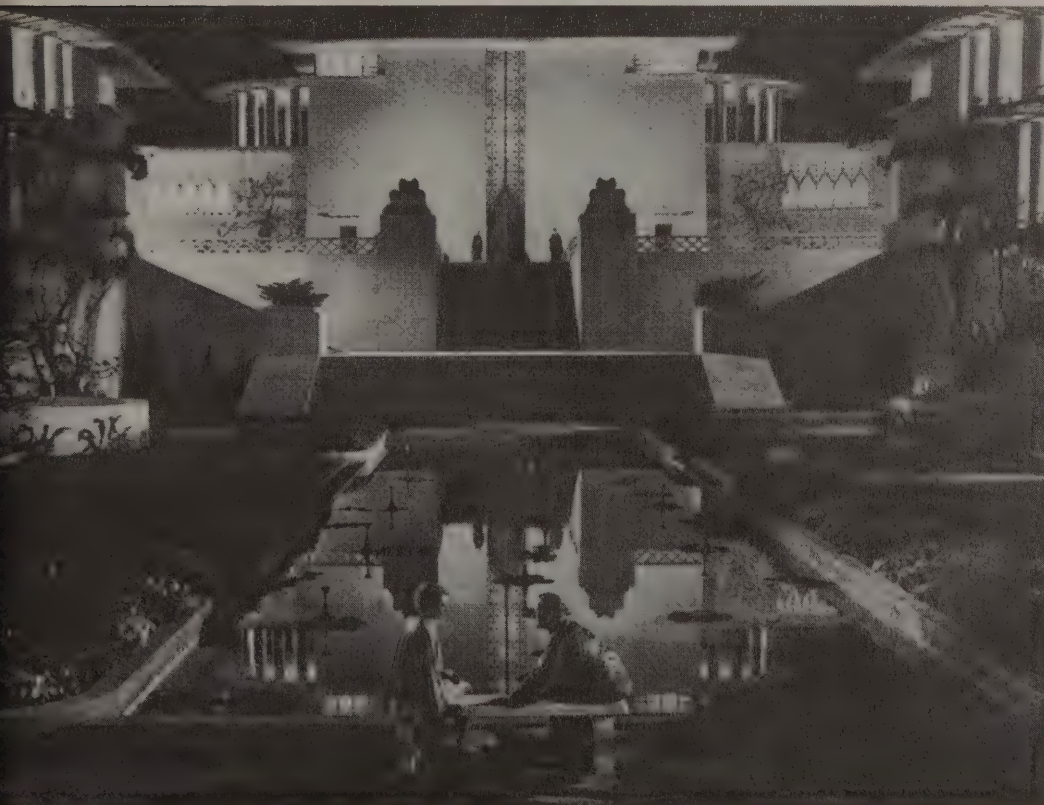



of the production. For all I know, these movies were made in someone's bedroom in Hyderabad! Call me old-fashioned, but for me, Bots are not proper replacements for human actors.

I understand the North American Trading Block (NATB) has just elected a new Chief Representative. What do you think of her? My Dad says that in America elected officials are irrelevant to people's day-to-day life, that in the NATB people do what they want to do. However, I can't help but wonder if Americans like their president as a figurehead, as it used to be for the Thai people and their royal family.

Did your family give you Special Genes when you were born? My parents told me they didn't, just the usual anti-cancer, anti-HIV molecular strategy. But after a lot of trying I figured out how to crack into my personal file on the Network, and found out that I have a few Special ones, as well. A couple of them are there to help me get old slower, so that I'll hopefully live to 120 or so. A few of them are there to give me a mild boost in intelligence. I guess this explains why my parents didn't figure out how to encrypt my personal file from my prying eyes! Anyway, some people in my country are opposed to people trying to give their kids an edge in life, so I guess that's why they didn't let on about it. It's sort of like how adults are about New Skin surgery—everyone does it, but nobody wants to admit it. I've heard that people in other countries are experimenting with all kinds of mods for their kids, for height, good looks, etc., but I think that's all a little silly. Just watch, Nestor—in the future, so many people will look alike from all these bodily modifications and genetic alterations, that the cool thing will be to have been born Natural, just like me. At any rate, I'm not worried—I like who I am and I think I'm going to do just fine.

The other day I took an elderly Australian couple on a trishaw ride around an area we call the Gulshan. This is a very prosperous area, with a lot of the nice shops you probably also have in Tejas. Anyway, they said they had just gotten back from a "third honeymoon," a trip to Mars. Have you ever heard of such a thing, a "third honeymoon"? My parents think just a second is a silly idea. At any rate, this couple, though they both said they were in their early one hundreds, seemed to be quite healthy and spry, and they both spoke of taking long hikes in space suits, several miles deep into the canyons of the Red Planet.

My parents were married with a new legal instrument we have here, which we just adopted from the West. You're probably familiar with it; it's

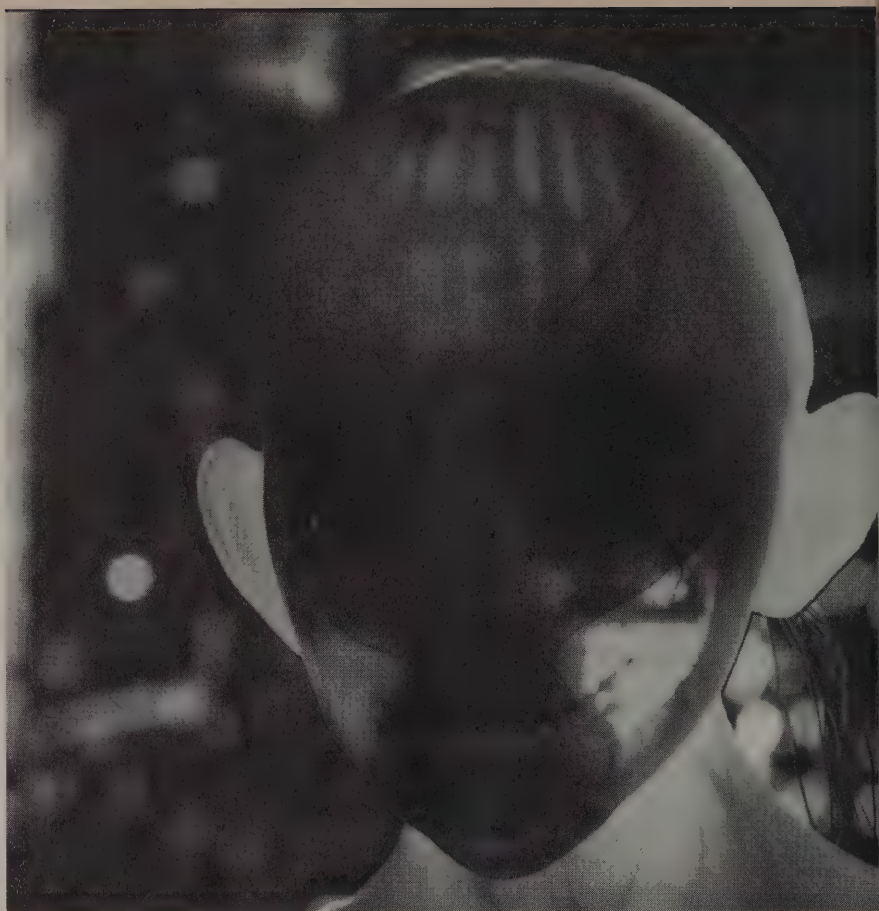

a marriage with an expiration date. If the relationship isn't doing well on the expiration date, which in this case comes every ten years, then they go their separate ways, and the legal agreement comes to an end, with personal effects being split up according to a pre-written document. So far my parents have made it through two of these periods, and I have to say, an expiration date really isn't for them, because as far as I can tell, they're one of the happiest couples around. I only hope that I can one day find someone I get along with half as well as my Mum and Dad do with each other. With almost everyone relying on love marriages these days, it's up to me!

Well, Nestor, I've written an awful lot about myself and my circumstances in this letter. I look forward to hearing about you. Indeed, despite all the progress humanity has made in the last couple thousand years, to say nothing of the last several decades, when it comes down to it, what still matters most to us is our lives and our loved ones.

Yours truly,  
Ramesh

A second-generation face robot, back-lit to reveal its machinery, from the Hara-Kobayashi laboratory of the Science University of Tokyo. From the remarkable new book, *Robo sapiens: Evolution of a New Species*, by Peter Menzel and Faith D'Aluisio, reviewed p. 71.





## LETTERS

*Whole Earth* is a conversation. Compliments, cavils, and corrections are welcome. Letters and e-mail may be (reluctantly) edited for space or clarity.

Dear Mr. Warshall,

I hate to repeat what other people say so I want to try a different way to describe how much I appreciate what you're doing with *WER* and me: Have you ever stood on the summit of Everest and looked out over? That's enough. You understand. If you cry your tears will freeze, but you do anyway.

Thank you.

Sincerely,

David Burgess

Parma, Italy

### Beyond Left and Right I

Dear Editorial Staff,

I just wanted to send my sincere thanks for the wonderful "Beyond Left and Right" section in the Summer 2000 issue. How refreshing! When I poured through the compilation of across-the-board writers, I gleefully thought: "I am not alone in the world." There is such a thing as a Green Conservative after all!

Thanks,

Justin Throne

by e-mail

### Beyond Left and Right II:

We have met the enemy and he/she is...

Dear Editor,

For years, I've been an avid reader of your publications. Every issue is savored article by article and I always keep the back issues and reread the articles I enjoyed most. I have tolerated the irrational bent of some of your contributors to glean out the good stuff and there has been a plethora of good stuff.

The summer 2000 *Whole Earth* motivated me to communicate some of my thoughts to you.

How can a person claiming to believe in self-reliance support a huge regulatory bureaucracy which denies freedoms to all but the politically correct or those who are well connected?

How can an individual who believes in freedom support laws which ban an adult's right to buy and use a drug or buy and use a gun in self-defense?

With the knowledge that many homes are being invaded without search warrants today, why would a citizen want to give up their right to bear arms?

How can one reason that the life of a convicted murderer is more valuable than the life of an unborn child?

How can anyone place the blame of all the world's environmental destruction or for our health problems on corporations when *we*, the *consumers*, are obviously the ones to blame?

I suggest most of the threats to society and to Gaia can be alleviated by the following:

Each of us must take responsibility and be held accountable for our actions.

Each of us must limit our consumption after our basic needs are met.

Each of us must allow and protect all others' rights to receive their basic needs. That's right, a fervent, action-provoking love of ourselves, of others and of all life is the only way to survival. Chaos is the alternative.

Sincerely,

Harold L. Phillips

Palm Harbor, FL

### Beyond Left and Right III:

Babylon and Faith

Thanks folks,

A friend sent me a copy of your Summer 2000 issue, for which I offer great thanks. As a former US Senate Judiciary Committee minority counsel turned Bible teacher and writer, I am always looking for ways to link solid social analysis with the rediscovery of the radical socioeconomic message of the Bible. My own work on the Book of Revelation (*Unveiling Empire: Reading Revelation Then and Now*, Orbis, 1999, coauthored with Anthony Gwyther) attempts to wrestle the most radical book ever written from the hands of the "end of the world" folks to return it to those who, like *Matrix's* Neo, sense something wrong with the world. Our conclusion is much like that of your authors: people of faith are "called out" of "the great city" (aka "Babylon" or "empire") and into the realm in which only the ways of the Creator are worthy of ultimate trust. Having seen the lie of the Washington, D.C. system up close, I revel in insightful writing such as yours which transcends this nonsense and offers a clear alternative.

I intend to use some of these articles in classes at Seattle University and in church programs in which I teach.

Shalom,

Wes Howard-Brook

Seattle, WA

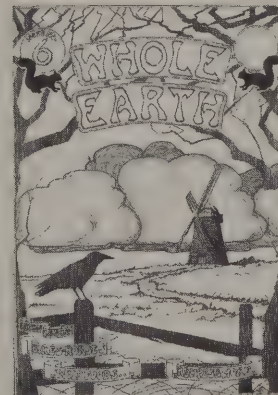

First *Whole Earth* published in Brighton, England (1974-1979). "We unashamedly borrowed the name from the *Whole Earth Catalog*."  
—Horace Herring, Huntington, England



## Punk Aztecs on Steroids...

My school district, in New York's Mid-Hudson Valley, has become embroiled in controversy over the removal of its sports team mascot, the Onteora Indians. Ours is geographically the second-largest school district in the state, and its residents represent a broad range of viewpoints, from rural citizens whose families have lived here for generations to the arts colony and New York City bedroom community of Woodstock. On the walls of the Onteora High School gym and cafeteria, giant murals of a hook-nosed caricature "Indian" wave tomahawks or bust through brick walls. The image had always offended me. I was elated when the local organization COLOR, a group of multiracial families in Woodstock, took the issue on and demanded that the racist symbol be removed. This wasn't the first time the issue had been raised. Over the past several years, a local Native American musician had been trying to raise community consciousness with little success. People complained intermittently, but no serious action was ever taken.

However, the Onteora School Board had become increasingly liberal in recent years, and with this new wave of advocacy, the Board voted four to three to eliminate the Indian image and name. Vocal district residents took up arms against the decision. The Indian mascot had been a part of Onteora's history for forty-nine years. Partially due to the human inclination toward the status quo, and partially due to the power of this or any symbol and its place in a community, there was an avalanche of public sentiment to restore "the Indian." Many complained that removing the image without the community's consent was not only unfair, but "un-American." The issue took a life of its own.

As a junior at Onteora High School, I saw my school become a microcosm of the situation in the larger community. The school administration could have taken this opportunity to make a connection between this conflict and its historical counterparts, or at least allowed us time for open discussion on the various points of view concerning the mascot,

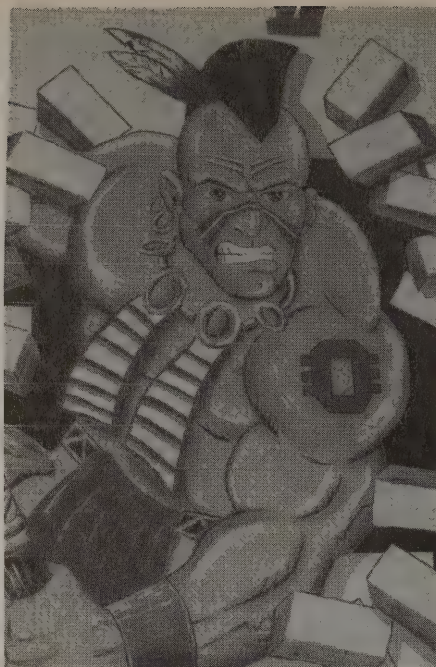

Indian caricature on walls of Onteora High School.

but it did nothing of the sort. Despite its proximity to an "arts colony," Onteora has always been more focused on sports, and most of my fellow students were outraged that something was being taken away from them. At the same time, school board elections were fast approaching. Locals who had lived in the area for generations feared they were under attack by the "politically correct" brigade, and this hysteria was reflected by the school board lineup, who, for the first time, ran on two opposing slates. The more conservative of the two ran with a single-issue campaign: to reinstate the Indian mascot. Throughout the campaign, all other issues were overshadowed by the conflict over the Indian.

Campaign signs were torn down overnight, threatening phone calls were made, fistfights erupted. People who had never voted in a school board election in their lives arrived at the local elementary schools in droves to prevent the "liberals" from taking away a symbol of "school spirit." The candidates with a pro-mascot platform won by a two-to-one margin, and now those of us who wanted an end to the mascot and all it represents have found ourselves faced with a more distressing situation than the one that began the controversy.

Above all else, people in favor of

keeping the mascot are confusing the issue. This is an issue beyond school tradition or community consent; it is one of blatant disregard for the feelings of the minority. If Native Americans, or any group of people for that matter, are offended by the image, then it qualifies as a racist image. If they have spoken out against it and been dismissed or ignored, then it becomes intentional racism.

Some people in the area in favor of retaining the mascot insist that they are keeping it because of their respect for the traditions of the local tribes. However, there is a very small Native American population in the Onteora School District, who, aside from preferring to preserve their *own* culture as they see fit, do not, nor have ever in their tribal history, painted red lightning bolts across their faces or worn thick gold earrings and chains, as our mascot does. The Indian painted on the walls of the gymnasium bears more resemblance to a punk Aztec on steroids than to any member of the indigenous population, past or present. The use of bastardized versions of objects sacred to various Native American cultures, such as totem poles, drums, or feathers on the covers of yearbooks and prom posters is confusing the secular with the spiritual, particularly with a religion which we have no connection with ourselves. The primarily Judeo-Christian populace of the Onteora school district is insensitive to this issue because they cannot see a parallel. Also the fact that we are identifying ourselves with the warriors of old raises two additional points. Not only are we placing Native American people in the past, alongside Spartans and Vikings, but we are portraying them as primarily warlike people, another painful stereotype.

I doubt any of these cartoonish images were first put into place with the specific intent to demean the offended parties, but most of them have remained unchanged since the fifties or earlier, and as a country, I should hope we have grown more aware and respectful of one another over the past several decades. However, when the opportunity to put this image behind us is presented, and the majority clings to it with an unprece-



dent ed fervor, the issue becomes more complex. Symbols are clearly important, and our adherence to them against all odds will prevent us from moving forward as communities, and on a larger scale. If we are going to embrace symbols, let's not embrace them blindly, but rather choose an image or idea that is inspiring and affirming to all members, without misrepresenting anyone.

Sincerely,

Shaina Kapeluck

Shokan, NY

(Shaina is now a college freshman. —Ed.)

### Naval Sonar

Thank you for your article "Submarine Song and the Naval Boom Box" in the Summer issue, about how the Navy Sonar places the oceanic life, particularly the marine mammals, in danger. Although the news is horrifying, I am glad for the opportunity your publishing this piece gives me to do something about the situation. I have already contacted about thirty friends of mine, pretty informed people, and none of them knew about it, so it was a real service.

This is the best link I have found for summarizing the issue, and what to do about it, for those who may have missed your article:

[www.ilhawaii.net/~light/faindex.html](http://www.ilhawaii.net/~light/faindex.html).

Thanks again,

Briseis Gatto

by e-mail

### End of Techno-Rapture I

Dear Peter,

You're putting out a really vital and crucial mag. It occurs to me that you might like the idea of asking the question we asked in an issue co-published by City Lights and *CoEvolution Quarterly* in Fall '78. The question we posed to various triple-thinkers was: Should pathogenic industrial civilization be dismantled (it being fatal to Earth and man)? Not many took us seriously, and the replies were generally disappointing. It would be timely today, considering the rapid advance of zero hour of the ecological clock, to update this question for an issue of *Whole Earth*.

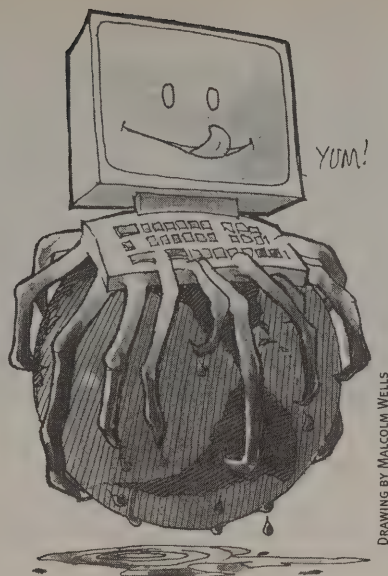

The question could be the same as the original, a quarter of a century later from the changed perspective of today.

Best thoughts and greetings,

Lawrence Ferlinghetti

### End of Techno-Rapture II:

#### No more steamrolling

I read the articles of Kevin Kelly and Stewart Brand on an "All Species Inventory" (Fall 2000) with interest. I'm pleased to see Kevin and Brand back to more ecological matters.

Since Bill Joy's superb indictment of the high-tech mavens ("Why the Future Doesn't Need Us," *Wired*, April, 2000), there has been a sea change. Folks who used to scoff at neo-Luddite fears now seem to be tripping over themselves to say that they supported many of these concerns all along....Look at digerati like Douglas Rushkoff and John Naisbitt. Compare the reckless claims of Rushkoff's early *Cyberia* with his much more sober recent book *Coercion*. Even more striking is the ludicrous boosterism of Naisbitt's *Megatrends 2000* compared with his latest, *High Tech High Touch* (greatly improved by the contributions of his daughter Nana), which openly speaks of "technologically intoxicated zones."

In his 1987 *Media Lab*, Stewart Brand was making statements like: "Once a new technology rolls over you, if you're not part of the steamroller, you're part of the road." It seems that some of us who were rolled over back then were consider-

ably more resilient than our detractors made us to be, and our once marginalized fears about the machine takeover are being echoed by mainstream publications worldwide (see: "Tech's Tyranny Provokes Revolt," *USA Today*, August 21, 2000; and "Why Computers Fail As Teachers," *US News and World Report*, September 15, 2000.)

Sincerely,

Bill McCormick

Charlottesville, VA

### End of Techno-Rapture III:

#### It's all a bunch of lies...

Dear Editor,

Hearing the recent hype about the promise of genomics, I recalled other technologies that were touted as miracles when they were introduced. These technologies yielded even more than their promoters pledged. Unfortunately,

Eccentric geniuses harnessed atomic energy to improve our lives. We had great fun hiding under our desks. Plus, the management of nuclear wastes has provided a real-life application of the concept of eternity and guarantees high-wage employment for ultrahazardous waste contractors well into the next millennium.

Agricultural technologies gave control of food production to the few who knew how to make the most money from it. That's efficiency.

Chemicals such as DDT, PCBs, MTBE, and chlorinated solvents were initially labeled "wonder" substances. Decades later, we suspect they cause birth defects, sterility, and cancer. Now we wonder how we will ever get all of this stuff out of our drinking water.

They said TV and the Internet would entertain, educate, and unify our society. And who can argue with the results? Now, billions can laugh—in simultaneous isolation—at jokes about how fat or dishonest Bill Clinton is and what Brittany Spears wore last night.

Artificial birth control was deemed a boon to women. Now both sexes can have sex with multiple partners, including married ones. You can see how happy that's made people. The personal ads are a mile long, women's magazines talk endlessly about men who won't

(continued on page 89)



# WHAT DO MARLON BRANDO, TOM PETERS, AND ALICE WATERS HAVE IN COMMON?

THEY HAVE ALL CONTRIBUTED TO *WHOLE EARTH*,  
ALONG WITH MANY OTHER GENEROUS FRIENDS

## PLEASE JOIN THEM NOW!

*Whole Earth* is supported by many readers, friends, and foundations. We gratefully thank all those who have given. In particular, the people listed below deserve special thanks. *Whole Earth* is published by Point Foundation, a not-for-profit 501 (c)(3) organization. On behalf of the magazine, Point can accept appreciated stock, equipment, or other tangible assets as donations. Direct inquiries to Devon King at 415/256-2800, ext. 221; giving@wholeearthmag.com; or *Whole Earth*, 1408 Mission Avenue, San Rafael, CA 94901.

### Perpetual (\$10,000+)

Grant Abert  
Allswell  
Marlon Brando  
Tyrone Cashman  
Center for Ecoliteracy  
Collective Heritage Institute  
Compton Foundation  
Flow Fund  
Foundation for Deep  
Ecology  
Richard & Rhoda Goldman  
Fund  
Alice Eve Kennington  
Marin Community  
Foundation  
Alice Michel  
Ryan Phelan  
& Stewart Brand  
The Philanthropic  
Collaborative  
Preservation Fund  
Sacharuna Foundation

### Angelic (\$5,000+)

Jenifer Altman Foundation  
Jeffrey Bronfman  
Kimo Campbell  
Crimson Crabtree  
Felix Dennis  
Fred Gellert Family  
Foundation  
Diana Hadley  
Frances Harwood  
Kingsley Murphy, Jr.  
Institute for Noetic Sciences  
John Larson  
Joshua Mailman  
Richard Rockefeller  
Starfire Foundation

### Maniacals (\$1,000+)

Jaime Lubin Acosta  
Cash Adams  
Petra Akwai  
Jules Alciatore  
Denise & Norman Alm

Kathy Archibald  
August  
Michael Lee Bailey  
Bambu Flyingwater  
John Perry Barlow  
Leona & Bruce Baumgart  
Bernard Bildman  
Steve Blake  
Bernard Bonno  
Allen Boorstein  
Alex Bornstein  
Donna Boyd & Gene Combs  
Mark & Amanda Brady  
Jim & Anne Bredouw  
Stephen & Julie Briggs  
David & Sandra Burns  
Andre Carothers  
Kelly Celmer  
Harvey Chang  
Polly Cherner  
Continuous Wave  
Joe S. Coulombe  
Alasdair Coyne  
Carol Cricow  
Harriet Crosby  
Jerry Crutcher  
Bob Culley  
Henry Dakin  
W. Dale, Jr.  
Tim Dalmiau  
Arie de Geus  
Lynn Dondero, M.D.  
Richard Doty  
Robert Dunn  
Editora Espaco E Tempo  
Ltda.  
Institute for Intercultural  
Studies  
Francesca Kress Foundation  
Hilary Fried  
Jonathan Frieman  
Alex Funk  
Toni Garrett  
David Gotlib  
Ed Grover  
Eric Haines  
Haines Borough Public

Library  
Hampshire College Frog  
Daniel Hancock  
Stephen F. Haust  
Paul Hawken  
Johanna Hill  
David & Kay Hines  
Stephen Hodgkin  
Allan Hogle  
Harold Hunter  
John Hunting  
R.W. Hurd  
Michael O. Johnson  
David Johnston  
Elizabeth Jones  
Mitch Kapor  
Richard Kent  
Kinswoman  
David Kittrell  
Kevin J. Kiwak  
Lawson Valentine  
Foundation  
Christopher Le Bret  
Lawrence Lewis  
Kevin Lindsey  
Viki List  
John Litt, in memoriam  
Steve Littlewood  
James E. Lovelock  
Lucky Loner of the Lurker  
Legions  
Antione Maamari  
Randy Mack  
Douglas Martin  
Bill Mayben  
Jack Mayberry  
Luther & Gloria McLeod  
Gregory McMillan  
& Brenda Martin  
Pierce McNally  
Arthur Milholland, M.D.  
Elise Miller  
Russ Molari  
James Moores  
Joseph Murphy, Jr.  
Michael Nathan  
W.K. Nelson

Anne Norcia  
Nothing Matters,  
Everything is Important  
Joshua Notowitz  
Ray Olszewski  
Gary Owens  
Norman Pease  
Tom Peters  
Surse Pierpoint  
Plant Just One Tree  
Julian Price  
Ron Pruitt  
J.H. Reynolds  
Pierre A. Rioux  
Marcelo Rocha  
Maria Rodale  
Hans Nick Roericht  
Alexandra Rome  
John Romkey  
Jonathan Rose  
William Rosenzweig  
Bret Russell  
Jim Sanders  
The Schumacher Family  
Jim Sells  
Norman & Joanna Sher  
Virginia L. Smith  
Lydia G. Storey  
Marion Sweeney  
Mack Taylor  
Jack Tempchin  
Katherine Tremaine  
R. Burr Tweedy  
Marc Valens  
Gary Waldron  
Bob Wallace  
Alice Waters  
S. Ashley Webb  
Betsy Weedon  
Samuel Wigley  
David Williams  
Greg & Pat Williams  
Linda Wilson  
Gertrude  
& Theodore Winsberg  
Michael Woo  
Kirk Wood

WHOLE EARTH IS PUBLISHED BY POINT FOUNDATION, A NOT-FOR-PROFIT 501(C)(3) ORGANIZATION.  
ALL DONATIONS TO THE MAGAZINE ARE TAX DEDUCTIBLE. PLEASE SEE DONATION CARD.



HELP  
KEEP THE  
FIRES  
BURNING.

GIVE  
A

TAX-DEDUCTIBLE

GIFT

save  
30%

OFF COVER PRICE

888.732.6739

www.wholeearthmag.com.com

# Whole Earth

ACCESS TO TOOLS, IDEAS AND PRACTICES

Please detach your completed contribution form, fold it and tape edge before mailing.

Your credit card will be charged at our offices.

or,

you can mail a check to Whole Earth at the address on the other side.

Thank you kindly.

Your contribution is tax-deductible (IRS No. 94-214-7154)

FOLD HERE

Yes, I want to support Whole Earth to aid in its mission of spreading new ideas, paradigms, tools, and practices for future generations.

\$50  \$75  \$100  \$250  \$500  \$1000  \$5000  Other

Payment Method

Check (Payable to *Whole Earth*) or Charge my:  VISA  Mastercard

Account Number: \_\_\_\_\_

Expiration Date: \_\_\_\_\_

Signature: \_\_\_\_\_

# Whole Earth

ACCESS TO TOOLS, IDEAS AND PRACTICES

## SAVE 30% OFF THE COVER PRICE!

GET WHOLE EARTH FOR ONE YEAR (4 ISSUES) FOR ONLY \$20.00

Name \_\_\_\_\_

Address \_\_\_\_\_

City/State/Zip \_\_\_\_\_

Email \_\_\_\_\_

Bill Me Later

Payment enclosed

Canada: US \$24 includes postage and GST. All other foreign countries: US \$27. Please allow 6 to 10 weeks for first issue.  
For new orders only.

300351



**BUSINESS REPLY MAIL**

First-Class Mail, Permit No. 292, Denville, NJ

POSTAGE WILL BE PAID BY ADDRESSEE

**Whole Earth**

P.O. BOX 3000

DENVILLE, NJ 07834-9879

NO POSTAGE  
NECESSARY IF  
MAILED IN THE  
UNITED STATES



**BUSINESS REPLY MAIL**

First-Class Mail, Permit No. 292, Denville, NJ

POSTAGE WILL BE PAID BY ADDRESSEE

**Whole Earth**

P.O. BOX 3000

DENVILLE, NJ 07834-9879

NO POSTAGE  
NECESSARY IF  
MAILED IN THE  
UNITED STATES



HELP  
KEEP THE  
FIRES  
BURNING.

GIVE  
A

TAX-DEDUCTIBLE

GIFT

save

30%

OFF COVER PRICE

888.732.6739

[www.wholeearthmag.com.com](http://www.wholeearthmag.com.com)



commit, and there are so many divorces that parents don't even have to feel bad about splitting up anymore. Mint-flavored Prozac and Ritalin ensure that the whole process runs smoothly for kids from broken homes.

Of course, genetic technologies may trigger agricultural blights, irretrievably widen the gap between the rich and the poor, cause people to consider themselves and others to be machines, and deliver other unwanted surprises. But that's progress.

So, the geneticists should get busy. As scientists, they've got a strong tradition to uphold.

Mark Oshinskie, J.D.  
New Brunswick, NJ

### Whole Foods, Whole Paycheck

We would be happier if you did not accept advertising from Whole Foods. They are an awful company: anti-union, outcompeting local community stores with driven campaigns. But we love your magazine, so we are renewing anyway.

Harlan Glatt  
Santa Cruz, CA



### LONG LEBE DIE GANZE ERDE!

(Long live *Whole Earth*!)  
Werner Pieper, whom Timothy Leary called "Germany's most exciting cyber-shamanic-psychedelic-performing-publisher," published *Maximum Respekt* in 1999, with a whole section on the *Catalog*, *CoEvolution Quarterly* and revival of *Whole Earth*! It includes photos of numerous covers. Our staff German is *nicht* that *gut*, but it looks like an honorable and amazing read.  
[www.gruenkraft.com](http://www.gruenkraft.com)  
Werner Pieper, Medien Xperimente, Alte Schmiedel, 69488 Löhrbach, Germany.

## Verwechsele die Landkarte nicht mit der Landschaft!

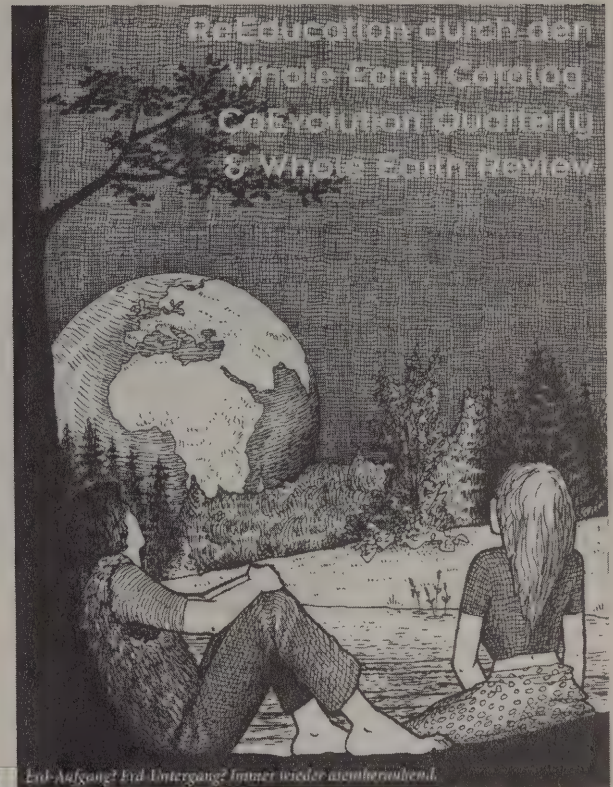

## *Last Chance To Honor Good Works: The Margaret Mead 2001 Awards recognizing community creativity for a new century*

from the Margaret Mead Centennial Committee, Institute of Intercultural Studies, and *Whole Earth*

**"Never doubt that a small group of thoughtful, committed citizens can change the world."  
— Margaret Mead**

When Margaret Mead died in 1978, she was the most famous anthropologist in the world. In her honor, starting in 1999 and continuing through the centennial year of her birth in 2001, *Whole Earth* and Margaret Mead's foundation, the Institute of Intercultural Studies, will come together to honor small groups of thoughtful, committed citizens who have changed the world.

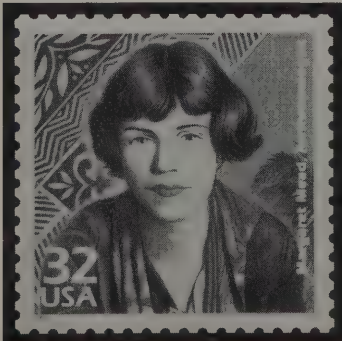

Mead always believed in the human capacity to change, insisting that the cultural habits of racism, warfare, and environmental exploitation are learned. She promoted human diversity as a teaching tool; pointed to modified traditions and new institutions that had successfully adapted to a changing world; and praised groups who were inspirations, models, and vehicles for learning from one another. Her goal was nothing less than intercultural and international understanding as a foundation for human freedoms.

If you know of a small group (fewer than 100 people) anywhere on the planet that has worked to change the world; that has cross-connected issues such as race, environment, intergenerational learning, child rearing, and gender understanding; that has developed an organization or series of tools that others can learn from; and that takes a long view of cultural understanding, please send your nominations to:

Mead 2001 Awards PO Box 3223 Petersborough, NH 03458 or [nominate@mead2001.org](mailto:nominate@mead2001.org)





An overly enthusiastic *Whole Earth* fan buys the most recent issue of the mag at SolFest from Emily (left) and Devon (right) who had never met him before.

### Report from the Front

This fall season was as packed as the San Rafael/East Bay 5:45 Bus #40 that Em and I take each day. At SolFest (the festival of Real Goods at Hopland, CA) there was lots of hair and not enough shade. Julia Butterfly Hill and Ralph Nader inspired all, as always. Sleeping on the woodchips under our table (that's what you call serious commitment to the cause!) was delightfully comfortable. A particular editor forgot her tent which would have been nicer....Real Goods has just saved itself by merging with Harmony and will provide even more green products like solar plates.

The Watershed Poetry Festival (Berkeley), the Breast Cancer Hike (*WE* raised \$1,200 bucks, baby), and the Bioneers conference (San Rafael) left us in a wild whirlwind of great ideas, stories, and new subscriptions. Our minds were completely rocked by Alice Walker at Bioneers, which is always appreciated. I also learned why a horse can be more profitable than a tractor, and no that's not the start of a weird joke. [Top corny remark was Joe Salatin's: "Back in West Virginia where I live, we never lock our car doors; except in late August when everyone's trying to ditch their extra zucchinis."—PW.]

So, how was your fall? I thoroughly enjoyed mine because of all the dedicated readers I was able to meet, and all of the kind folks who helped support us. Your humor and shared memories make our job much more interesting, and remind us of the long line of *Whole Earthers* whose shoes we borrow sometimes. So let's keep it going, shall we? And if you think that is a call for donations, well right you are. Happy holidays.—Devon

### Editor Emily's Reservations

With all due respect to the brilliant minds who help and make this publication what it is, and to Kevin, who voluntarily put together this great issue, there are just a few reviews in here that are not sitting well with me, particularly the Nike one on page 23.

It shouldn't be any new news to anybody. Nike has sweatshops in Indonesia and Vietnam. Like so many other American corporate mongers, they have taken their business into Third World countries where they employ the locals at poverty wages and continue to increase their profit margins by taking advantage of the Third World economies. This is a system that can be changed. (Not necessarily by eliminating sweatshops, but by establishing an independent monitoring system with an international union to

ensure that employees are not being overworked, underpaid, threatened physically or verbally, working in an unsafe environment, etc.) According to Community Based Abroad, an independent organization out of Australia, Nike employees are currently working up to sixty hours a week and earn under \$40 a month. Paul Hawken told PW that since Nike's bad press, conditions have improved and are even better than at other corporate sweatshops. But is "better" good enough?

These comments have nothing to do with being Green, PC, liberal, or conservative. They are about trying to be a responsible editor and a conscientious human. Sometimes thinking about tools goes beyond Swiss Army Champ knives and Home Depot's purple duct tape.

For more information about Nike and other sweatshops, go to [www.nikewages.org](http://www.nikewages.org), [www.caa.org.au](http://www.caa.org.au), [www.uniteunion.org](http://www.uniteunion.org), [www.coopamerica.org](http://www.coopamerica.org). —Emily

### Have I Cried Wolf Too Often?

I know we seem immortal and have kept on going despite our pleading for help again and again. And despite our subscribers' unique and unfailing generosity to date, we still need your gifts and donations to continue. Megabookstores (page 86), the closure of independents, increased postal and paper rates, etc. have taken their toll. Here are a few ways you can help:

- We need two G4 400 Macs. Our ancient overworked system is flashing red lights and crashing daily.
- We need a digital camera.
- We need a new publisher with special desire to expand circulation and newsstand presence and help with grants and philanthropy. Young and dedicated is fine (see our Web site or call for more information).
- We need about \$50,000 for immediate needs.

Thanks as always.

Peter Warshall, editor





## BOOK BRAWL: Act 5

Here's background for new readers. We've been following changes in the book industry, because books are what our readers love. The book brawl started fifteen years ago when megabookstore chains deeply discounted bestsellers, as well as other hardbacks and paperbacks.

Publishers and megastores made special deals. Borders, Barnes & Noble, B. Dalton, and the price clubs received earlier shipments and special pricing. The result: independent bookstores (which relied on the *NY Times's* bestseller list for basic income) shut down en masse.

The book brawl escalated when, about five years ago, online book sales got lots of media play for their discounts, convenience, and wide selection of titles. Amazon.com sold *NY Times* bestsellers at discounts of as much as 50 percent, just above wholesale. Playing follow the leader, Barnesandnoble.com and others matched Amazon.com. Again, the media pronounced the impossibility of independent bookstore survival.

Note: It was megastore/online promotional advertising and the loss of bestseller sales that closed most independents; not competition for sales of less touted books.

## Today's Installment

Megabookstores and the dot-coms, having forced the closure of thousands of independents, are now raising bestseller prices, eliminating discounts on paperbacks, cutting discounts on slower-selling hardbacks, and shortening discount lists. Barnes & Noble now marks down fewer than 150 of its roughly 150,000 titles. Borders discounts about 100 of their 150,000. Online discounting is quietly following suit. The New Economy hype—that no store rents, no store clerks, and better management at centralized warehouses permit greater sales and steeper discounts than ye olde brick-and-mortar independent bookstore—has not panned out. (Does this remind you of the hype that computers would cut paper use?)

After you add the \$4.50 postage (for a single-order book), online books have become equal to or more expensive to purchase. In fact, you would need to buy five paperbacks online, at one time, to match brick-and-mortar store prices.

Online services account for only 5 percent of all book sales, yet they remain very attractive for book readers who are tied to desks, are not price sensitive, and/or have no local bookstore. And Megabookstores remain attractive in certain smaller cities where they double as community or neighborhood centers. But definitions blur, many independent bookstores maintain their own online services, and some don't charge for shipping.

*Whole Earth's* staff, not overly impressed by Amazon.com (even its allegedly miraculous selections), switched the linkages on our Web site, [www.wholeearthmag.com](http://www.wholeearthmag.com), to the largest independent online bookstore service (Powells.com), when the American Booksellers Association's (the "independents")

[www.booksense.com](http://www.booksense.com) kept postponing its launch date.

The surviving independent bookstores have a breathing period to recover and prosper. Here are a few suggestions from our readers:

Combine selling new books with selling used books.

Add a coffee shop so that the community has a place to hang out. (Borders has been successful at this.)

Stock titles needed by local college students (many students prefer a bookstore's ambience to the library's; many on-campus bookstores are run by the chains). An active bookstore attracts customers.

In this interlude, be aggressive. Advertise comparative prices, clerk intelligence, conveniences, and activities like poetry readings and readings for kids.

Stock books that megabookstores and online services do NOT have or have only at the same level of convenience (e.g., two-week delivery), especially bioregional field guides, local history, and fiction.

Add music and videos your community needs and wants (vs. "family" chain music/video stores).

It looked to many like an imminent ten-count for independent and local bookstores, but maybe it was just a few hard rounds. —PW

## Corrections

The correct title for the excellent video reviewed on page 79 of *Whole Earth*, Fall 2000 is *Act of War*, and the correct e-mail address for ordering it from Na Maka o Ka 'Aina is [namaka@interpac.com](mailto:namaka@interpac.com). We apologize for the mistakes.

## Thanks

Special thanks to R.W. Hurd, Elisabeth Hoffman, and John Bayles, who donated during this issue.

Thanks to Stewart Brand, Paul Donald, Paul Ramirez (KQED), Alexander Rose (Long Now Foundation), Janice Sager (KQED), Helena Podd (*The Economist*), Richard O'Brien (*Outsights*), Froydis Cameron (Shell), Peter Menzel.



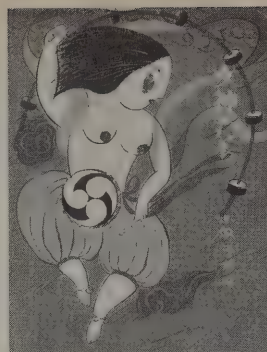
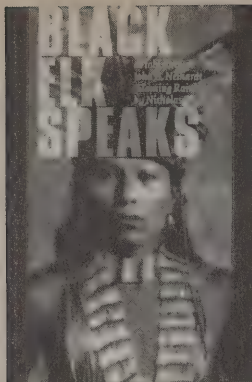

### GODDESSES

Mayumi Oda. 1999 (reprint ed.); \$35 (\$40 postpaid). Editions Gaia, 1795 Shoreline Highway, Sausalito, CA 94965, fax 415/383-6614.

It is impossible not to love the works of Mayumi Oda—lyric, dashing, graphically wild, feminine, strong. On walls, they make homes feel

more joyful and transcendent. Here is her 1988 book called *Goddesses*, reprinted on bamboo paper, with impeccable color printing, bilingual, filled with personal notes. If you've never had a bamboo paper book, this is the gem to start the collection. Mayumi has contributed covers and art to *Whole Earth*, been a board member, and ceaselessly continues to suggest ways to keep the fires burning. —PW

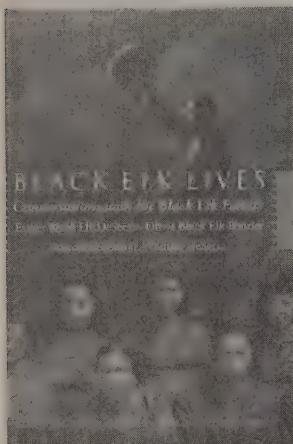

### BLACK ELK SPEAKS

Being the Life Story of a Holy Man of the Ogala Sioux

Nicholas Black Elk. 2000 (21st century ed.); 230 pp. \$12.95. University of Nebraska Press.

### BLACK ELK LIVES

Conversations with the Black Elk Family  
Esther Black Elk DeSera, Olivia Black Elk Pourier, Aaron DeSera Jr., and Clifton DeSera. 2000; 168 pp. \$25. University of Nebraska Press.

If a religious text of powerful import occurred in the twentieth-century, it was *Black Elk Speaks*. If both Eastern (Buddhist/Taoist) and Western (Judeo-Christian/Muslim) religious canons are to be challenged and grounded in new theology, a major source will be *Black Elk Speaks*. It has thoroughly changed young Indian paths of spiritual pursuit and begun to craft or re-craft many American religious practices. I'm talking here of a 500-year spiritual growth, not instant spiritual consumerism. Here is the new edition with a fine intro by Vine Deloria. For those who know *Black Elk Speaks* by heart, *Black Elk Lives* is a quiet update of Black Elk's family. It touches simply the quiet, the gentleness, and the honesty of his legacy. —PW

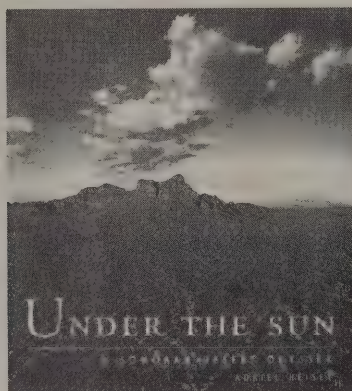

### UNDER THE SUN

A Sonoran Desert Odyssey

Adriel Heisey. 2000; 114 pp. \$40. Rio Nuevo.

Adriel Heisey's photos graced our cover and color section in Fall 1999, along with his first published piece of writing. He was just featured in *National Geographic*. Here is his first solo-flight book, of aerial photos and short life stories of the Sonoran desert. To a bioregional resident, this is a classic. It is also the first time an aviator/narrator of the calibre of St.-Exupéry or Beryl Markham has offered images of beauty equal to those of such photographers as William Garnett, John Shelton, and Marilyn Bridges. *Whole Earth* has been honored to be the first magazine to introduce such a self-reliant and elegant airplane-builder-and-designer, prose writer, and lover of place. —PW



## Don Michael

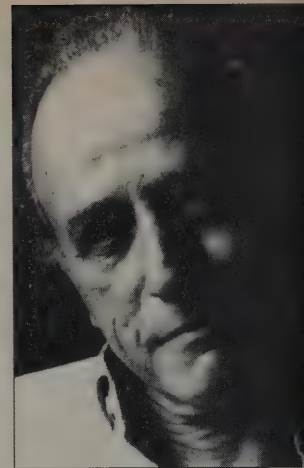

*"Experience the human and natural worlds as increasingly mysterious. My metaphor: the world and I are as a fruit — at once beginning and end, completion and decay, seeding new growth to completion to..."*

Don Michael was one of the most attentive and generous supporters of *Whole Earth*, not so much financially as with encouragement and advice. Former editor Ruth Kissane and Point Director Danica Remy particularly adored him (and he them). He was close friends with Contributing Editor Donella Meadows, Peter Warshall, and many others like Michael Lerner of *Commonweal*. We reviewed his salient text *On Learning to Plan—and Planning to Learn* in 1973. He offered his wisdom to everyone (the Joint Chiefs of Staff, the Club of Rome, Global Business Network, the American Psychological Association) and loved birds, paintings, and simple walking for mushrooms. In November Don died of complications from pancreatic cancer in his way—with Mozart playing and surrounded by immediate family.

### NEW TRAIN (CD)

Paul Pena. 2000. \$17.98. Hybrid Recordings.

In *Whole Earth*, Summer 1997 we interviewed Paul Pena, the remarkable Cape Verdean-American purveyor of blues and Tuvan throatsinging. Now *New Train*, recorded by Paul in 1973 but held up since then by music-industry politics, is finally available. The CD, cut during Paul's days touring with T-Bone Walker, features Jerry Garcia, Merle Saunders, and the Persuasions. Had it been issued back then, Paul would probably have received the recognition which has eluded him for years.

(*Genghis Blues*—a tuneful/touching/hilarious 1999 documentary of Paul's trip to Tuva for the national throatsinging competition—was nominated for an Academy Award. The VCR/DVD version is due shortly; see [www.genghisblues.com](http://www.genghisblues.com).) —MKS



BA Liberal Studies • MA Environment & Community  
 MA Education (also Teacher Certification) • MA Whole Systems Design  
 MA Psychology • MS Management

Antioch University Seattle's Graduate Programs in Environment & Community lead to the only Masters degree of its kind, combining social and natural science perspectives, collaboration and conflict resolution skills and interdisciplinary problem solving. Engage with the environment and your own community using our independent, self-directed curriculum.



Mary Dzieweczynski  
 MA Environment & Community 2000

## Put your passion to work...

Seattle Weekend and Limited Residency Options for both local and non-local students. Call 206/441-5352 ext. 5202 for more information, or visit our website.



2326 Sixth Avenue • Seattle 98121 • 206-441-5352 • [www.antiochsea.edu/ec](http://www.antiochsea.edu/ec)

# The water heater that takes conservation seriously.

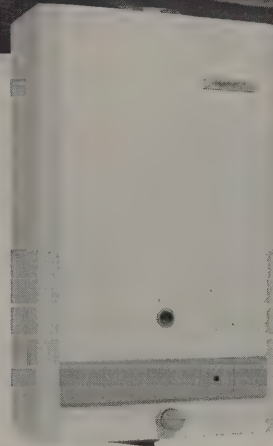

H: 29 3/4" W: 18 1/4" D: 8 3/4"  
 Available in LP or natural gas

Within the AquaStar's tankless design is a powerful blend of conservation and performance. It delivers unlimited hot water and only uses energy when hot water is needed. And, the AquaStar is built to last a lifetime, so the local landfill will be a little less crowded. If you're serious about conservation, call us for information about a serious water heater.

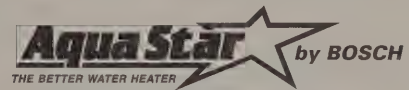

CONTROLLED ENERGY CORPORATION

800•642•3199 [www.ControlledEnergy.com](http://www.ControlledEnergy.com)

AWEM0600

# “Your ethics don’t have to be checked at the door when it comes to your money.”

— Anita Green,  
 Pax World Family Fund

The #1 RESOURCE for  
 Socially Responsible Investing is now in  
 PAPERBACK and FULLY UPDATED for 2001!

Out-perform the market and be a force for social change! This step-by-step guide answers all the financial basics and makes it easy to link your money with your values in a high-performance portfolio.

“If you are going to buy one book on socially responsible investing, this should be it.”

—AMY GRANZIN, [morningstar.com](http://morningstar.com)

ISBN: 0-86571-422-3

\$18.95 paperback



MAKING MONEY  
 AND MAKING  
 A DIFFERENCE

Hal Brill, Jack A. Brill  
 and Cliff Feigenbaum

FORWARD BY AMY BONISS

NEW SOCIETY PUBLISHERS

800-567-6772 / [www.newsociety.com](http://www.newsociety.com)



Original Teachings of  
**THEOSOPHY**

*Exploring the Human Condition  
in the light of THEOSOPHY*

Karma, Reincarnation, Human Nature, and Evolution

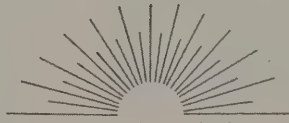

*"The eye seems to demand a horizon. We are never tired (or unhappy) so long as we see far enough."*

—RALPH WALDO EMERSON

As the oldest tradition of human wisdom, Theosophy has been expressed in different ages by such as Krishna and Buddha in the East, by Pythagoras, Plato and Jesus in the West. Bruno, van Helmont, Goethe and Schopenhauer, Shelley, Kipling and Masfield, Emerson and Whitman, to name but a few, have all upheld the doctrine given its full philosophical import in the Theosophy present by H.P. Blavatsky.

Theosophy is not a "Faith," for "Faiths" may be changed; but being knowledge which each can make his own, it is not dependent upon dogma or revelation. Theosophists do not demand acceptance of Theosophy; they point out its principles and their applications. Theosophy makes certain statements, but not as statements to be believed. The object of Theosophy is to teach man what he is, through showing him the necessity of knowing for himself and becoming his own authority.

*"Universal Unity and Causation, Human Solidarity, the Law of Karma, Reincarnation. These are the four links of the golden chain which should bind humanity into one family, one universal Brotherhood."*

—H.P. BLAVATSKY

For complimentary literature and information regarding meetings and study groups throughout the United States and around the world, please phone

(213) 748-7244 • FAX (213) 748-0634

<http://www.theosophycompany.org>

All meetings are free of charge and open to the public

**UNITED LODGE OF THEOSOPHISTS**

347 E. 72nd Street, New York, NY 10021 (212) 535-2230 • 245 W. 33rd Street, Los Angeles, CA 90027 (213) 748-7244

**HEALING THE EARTH**  
The Old Hawaiian Way



*Is your heart open to Nature's magic?*

From Serge Kahili King and the Hawaiian Shaman tradition: courses, books, tapes and tools to help you heal. Contact

**ALOHA INTERNATIONAL**

P.O. Box 665, Kilauea, HI 96754, (808) 828-0302

[huna@huna.org](mailto:huna@huna.org), [www.huna.org](http://www.huna.org)

Be sure to read Dr. King's acclaimed book,  
*Urban Shaman* (Simon & Schuster)

**Good Things  
DO Come in  
Big Packages!**



Adopt-A-Manatee<sup>®</sup> for someone special this holiday season. Your contribution will go toward efforts to protect endangered manatees and their habitat.



**Save the Manatee Club**

500 N. Maitland Ave.

Maitland, FL 32751

[www.savethemanatee.org](http://www.savethemanatee.org)

**1-800-432-JOIN (5646)**





Vicotiran Invention: The Pedspeed by Mayumi Oda (see Updates)

## CLASSIFIEDS

### CLASSIFIED RATES

\$3.00 per word (10-word minimum).  
\$2.75 for 3 issues; \$2.50 for 4 issues.  
Phone, URL, e-mail, and box numbers  
count as single words. Bold-faced  
words, add 50¢ per word. Only pre-  
paid advertisements will be accepted.  
**Credit cards are no longer accepted.**

Mail ad copy with check or money  
order payment to: *Whole Earth*, 1408  
Mission Avenue, San Rafael, CA  
94901. Ad copy can be faxed to:  
415/256-2808. You may also e-mail  
your ad to [ads@wholeearthmag.com](mailto:ads@wholeearthmag.com).

Deadline for Spring issue:  
January 28, 2001

### Back Issue Recycling

For Sale: *Coevolution Quarterly*, #6-46.  
(530) 475-3726

For Sale: 8 *Coevolution Quarterly*s, 48 *WERS*.  
[brettl65@altavista.com](mailto:brettl65@altavista.com).

### Books/Publications

What's in a leaf? Experience *THE MUSIC OF SUNLIGHT* for yourself. *PHOTOSYNTHESIS* is what's happening. [www.molecadv.com](http://www.molecadv.com).

*LIVING FREE* newsletter. About self-reliance,  
lifestyle alternatives. Sample \$1, 6 issues \$12.  
Jim Stumm, POB 29-WE, Buffalo NY 14223.

FREE CATALOG! Unique, effective Chinese  
herbal products, essential oils, books, and  
more! Call (800) 258-6878.  
[www.eastearthtrade.com](http://www.eastearthtrade.com).

"Unbought and unbossed." Friendly, candid  
publishing on modern folkways and cultural  
revival. [OutYourBackdoor.com/oyb](http://OutYourBackdoor.com/oyb).

### Business Opportunities

GRANTS \$500-\$5000. TO INDIVIDUAL WOMEN  
AGE 54+ for projects in any field that  
enrich/empower the lives of adult women. The  
Thanks Be To Grandmother Winifred  
Foundation, Dept. WE, PO Box 1449, Wainscott,  
NY 11975-1449. SASE appreciated.

ENJOY FREEDOM AND CREDIBILITY promoting  
proven superior 100% guaranteed water filtra-  
tion products. Standardized third-party certi-  
fication gives you clear marketing advantage.  
Professional assistance. FREE information.  
(800) 706-0708.

Escape the rat race through an organic income  
opportunity. Join a solid, 18 year old company  
at the leading edge of the natural and organic  
foods supplement industry — a huge mega-  
trend offering significant opportunities. Free  
audio tape. Call (800) 927-2527 ext. 00132.

### Communities

Feminist Ecovillages seek members - We invite  
you to visit or join us in living sustainably in  
spiritually diverse, rural intentional communi-  
ties. (888) 262-1724, [eco@ic.org](mailto:eco@ic.org),  
[www.ic.org/eco](http://www.ic.org/eco).

CREEKSIDE COHOUSING in Charlottesville, VA  
continues construction of a model house on a  
wooded five acre site close to downtown. The  
community will have 25 privately-owned units  
in several models, sizes and price ranges, and  
a common house, all designed by prize-win-  
ning architect William Sherman. A nearby  
nature trail is part of a city-wide trail system.  
City bus stop one block away. Prospective new  
members welcome. The community is environ-  
mentally sensitive and uses formal consensus  
process. Information at Website --  
<http://avenue.org/Cohousing>.

[www.circleoftheearth.org](http://www.circleoftheearth.org). THE WORLD WIDE  
MIND-SPIRIT WEB FOR NEW ARTISTS. The  
visionary, political, shamanistic community.

### Resources

[zenzibar.com](http://zenzibar.com) - A portal and directory of  
Alternative Culture, featuring NEWS, EVENTS,  
DISCUSSION GROUPS and more. Free Your  
Mind/Explore the Edge of Culture.

You can help Hawai'i reclaim her body and soul  
from foreign invasion and occupation. Support  
Hawaiian independence. <http://www.hawaii-nation.org>.

### MANDALA DESIGNS

Thanks to Mandala Designs, [www.mandala-designs.com](http://www.mandala-designs.com). for developing, updating, and  
hosting [www.Wholeearthmag.com](http://www.Wholeearthmag.com). Mandala  
Designs develops web sites for socially  
responsible businesses, including *Whole Earth*  
Magazine, and Shambhala Publications,  
[www.shambhala.com](http://www.shambhala.com).

## Reader Service

### TO SUBSCRIBE, CALL 888/732-6739

Subscription rates are: \$24 for 1 year  
(4 issues), \$42 for 2 yrs. **Canada:** \$32 for  
1 year, \$55 for 2 yrs. **Other international:** \$39  
for 1 year, \$70 for 2 yrs. International sub-  
scriptions must be paid in US funds.  
Mastercard and Visa are accepted.

### CUSTOMER SERVICE

Please address subscription inquiries to:  
*Whole Earth*, PO Box 3000,  
Denville, NJ 07834-9879.  
For international orders: 973/627-5162.

### CHANGE OF ADDRESS

Moving? Send us your old address, new  
address, and date effective. The US Postal  
Service is not obliged to forward second-class  
mail.

Mailing List: Occasionally we make our mailing list available  
to companies offering goods and services we believe might  
be of interest to our readers. If you do not wish to be includ-  
ed on those lists, please contact customer service as listed  
above.

*Whole Earth*, ISSN 0749-5056, published quarterly.  
Subscriptions: \$24 US, \$32 CDN, \$39 INTL. Mailing address:  
1408 Mission Avenue, San Rafael, CA 94901. Publisher:  
Alexander Gault, Editor: Peter Warshall. A non-profit sub-  
sidiary of Point Foundation. Total circulation: 32,479 actual,  
34,629 average; Paid/requested circ: 12,160, actual, 12,857  
avg; Paid/requested mail subs: 10,765 actual, 11,658 avg;  
Total paid/requested circulation: 22,925 actual, 24,515 avg;  
Free dist by mail: 2,234 actual, 2,139 avg; Free dist outside  
mail: 480 actual, 832 avg; Total free dist: 2,714 actual, 2,971  
avg; Total dist: 25,639 actual 27,486 average; Copies not  
dist: 1,021 actual, 1,564 avg; Returns: 6,840 actual, 7,143  
avg. Percent paid/requested circ: 89% actual, 89% avg.

AGRICULTURE - HEALTH CARE - ENERGY

1,050 Books on CD-ROM



The Greatest Independent Living Re-  
source of its Kind! In use in over 130  
countries, the Appropriate Techno-  
logy Library has the complete text and  
diagrams from 1,050 of the most  
practical self-reliance, do-it-yourself  
books. Over 150,000 pages!

1-800-648-8043

www.sustaintech.com

WIND POWER - WATER - BIOGAS POWER



# Adizes

## Graduate School ~ Online!

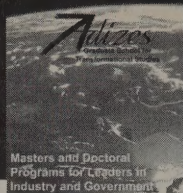

☞ Confront the new millennium with the power of your mind! Participate in the study of change with your peers from a variety of disciplines and cultures, examining change on, micro, mezzo and macro levels. Online!

☞ Bring your insight, your creativity, and your knowledge to bear on global issues and build upon the breadth and depth of your intellectual interests.

☞ Engage in collaborative dialogue, working from classic and contemporary theoretical frameworks.

**Small focused classes! Dynamic Faculty!  
Flexible Schedule!**

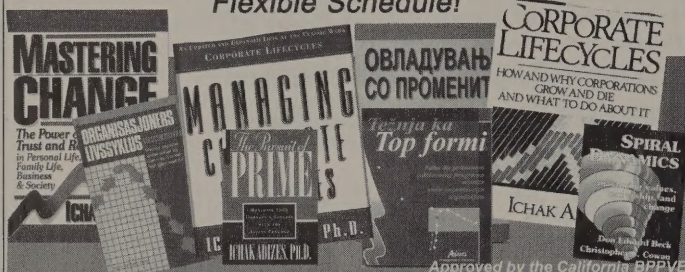

**Masters and Doctoral Degree Programs**  
[www.adizes.com](http://www.adizes.com) [AGS@adizes.com](mailto:AGS@adizes.com)  
 800-869-2226 request free brochure #W

## WE LIVE IN A BIOREGION... the coastal temperate rain forest of North America

We have more in common  
than state or national borders  
can obscure.

We understand  
that "ecosystem" and "economy"  
are two words for the same thing.

And that the wealth of community  
is based on the bonds  
between people and place.

We can find solutions to our common problems,  
*But first we have to start out on the same page.*

**Tidepool: Daily News for the Rain Forest Coast**  
[www.tidepool.org](http://www.tidepool.org)

An Ecotrust Project

## FAT CHANCE BELLY DANCE Mail Order Catalog



Videos  
Music  
Books  
Cosmetics  
Costumes  
Jewelry &  
Accessories

A Resource Guide for Tribal Style Bellydance

To request a free catalog, send a SASE  
with two stamps to: FCBD-WEM  
PO Box 460594 - SF CA 94146  
(415) 647-6035 - [www.fcdb.com](http://www.fcdb.com)

Announcing...

[www.prescription2000.com](http://www.prescription2000.com)

- ◆ Prescription 2000 Daily Multivitamin/Mineral Vegetarian Formula - *no animal products were used as a source or in the processing of this supplement*
- ◆ Free nutrition & integrative medicine research

Or visit us at

<http://www.animalfreeshop.com>

# Prescription 2000

Unparalleled Nutrition Research...  
Unique Dietary Supplements

(916) 483-1085 - (916) 483-1431 FAX

## The HUMANURE HANDBOOK

by Joseph Jenkins

Quintessential, classic guide to  
**COMPOSTING EVERYTHING INCLUDING  
WHAT YOU WOULD OTHERWISE FLUSH**  
1999, 2ND EDITION, 302 PAGES, ILLUSTRATED  
• AMAZON.COM #1 CATEGORY BESTSELLER •



Crapped in drinking water lately? Learn how to compost all household organic material; grow a food garden with humanure compost; understand the health issues; build a \$25 composting toilet; learn about alternative graywater systems; find sources of composting toilets worldwide. Includes a full review of state regulations.

Ask for it at your favorite bookstore or library.

Still only **\$19.00** US (plus \$4 s&h in the US)

**800-639-4099 (802-295-6300)**

[www.jenkinspublishing.com](http://www.jenkinspublishing.com)



# whole earth

*Whole Earth* provides access to absorbing ideas for the general reader and is recommended for all libraries.

—*Library Journal*

## SPECIALS FOR SCHOOLS

Many high schools, colleges, universities, and other places of learning remain stuck. No fun, no visions, no practical access; no vocabulary to talk about what's happening. Issues of *Whole Earth* are often the only texts that show the Big Picture and encompassing scholarship.

We'd like to help change things for the better. Buy 10-25 copies of these featured issues for your class and receive 30% off. Orders of more than 25 copies receive a 40% discount.

You can also donate a subscription to your library and get a tax deduction.

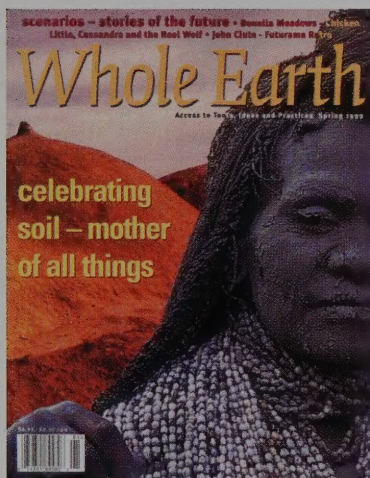

**#96. Spring 1999 — Soil:** The only survey of soil from every point of view: those of engineers, soil eaters, immunologists, farmers, natural capitalists, body painters, home builders, religious practitioners. This issue is a celebration of living soil, not a lamentation over erosion, pollution, or siltation. \$12 postpaid.

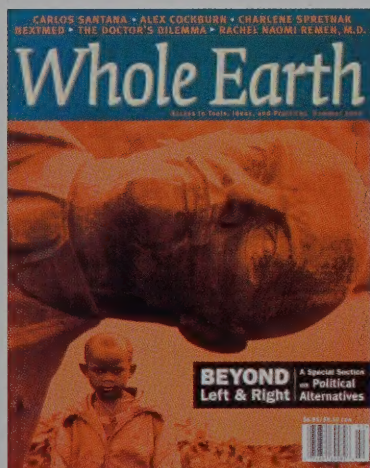

**#101. Summer 2000 — Beyond Left & Right:** An unorthodox look at the political spectrum. Is it obsolete? Leftists, rightists, libertarians, and greens look for issues on which to agree and disagree. Do we live within a media-generated Matrix? An inside account of radical politics and the civil rights movement. Also in the issue: "Next Med": the not-so-comforting future of medicine. \$12 postpaid.

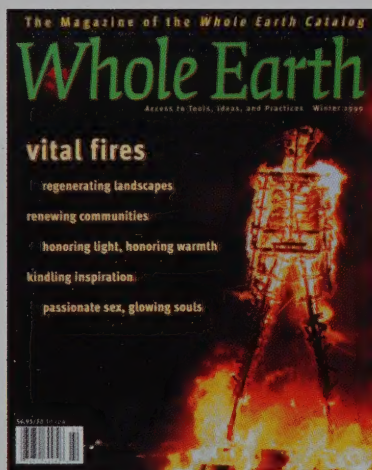

**#99. Winter 1999 — Vital Fires:** Steve Pyne, who greatly guided this issue, has written the grand tomes on fire in the history of the Earth. Here is the story of the long burn, from pre-human ignition to atom splitting and bromine fuels. Our broad survey includes fire to regenerate landscapes; fire rituals to renew communities; fire as an honored source of light and heat. Access to the best books and Web sites. \$12 postpaid.

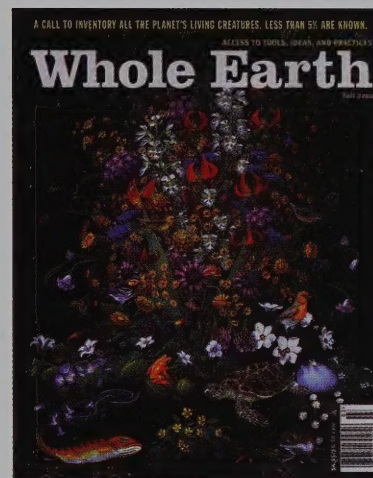

**#102. Fall 2000 — All Species Inventory:** Only 5% of Earth's species have been described. This is the first and only magazine to promote an all species inventory. How to discover the 10 to 100 million unknown species? To utilize "barefoot taxonomists"? To combine natural history with digital technology? Which groups need most attention? E.O. Wilson, Miriam Rothschild, Stephen Jay Gould, Lynn Margulis, Vladimir Nabokov, Stewart Brand, Kevin Kelly, David Quammen. Also: the non-tourist Hawai'i, with bioregional photos and access. \$12 postpaid.

## BACK ISSUES

**Back Issues** (\$12 each, postpaid)

#15-24, 29, 31, 33, 35, 39, 41-44, 46-47, 59, 62, 65-67, 70-71, 73-76, 78-84, 86-94, 96-102

**Endangered Issues** (\$50 each, postpaid):

#2, 5, 10-14, 25-26, 28, 30, 32, 34, 36-38, 40, 45, 48-50, 53-54, 56, 58, 63, 72, 77

**Special 30th Anniversary Issue** (\$14.95 postpaid)

#95 - Reprint of the original 1968 *Whole Earth Catalog*, plus thirty-four pages of new essays.

CALL: 888/732-6739

OR WRITE: **WHOLE EARTH**, PO Box 3000, DENVER, NJ 07834-9879



# Sentiment without **ACTION** is the Ruin of the **SOUL**

~ edward abbey

*Thank you for taking action.*

Only 20 percent of the Earth's old growth forests remain intact today.

These majestic treasures have been cut at an alarming rate in recent years, only to be turned into products like lawn chairs, toilet paper and disposable office supplies. However, as a result of public pressure from people like you, some 300 companies including Home Depot, Kinko's, and top homebuilder Kaufman & Broad have committed to rapidly phase out their sale or use of wood from endangered forests. These corporations make up some 25 percent of the wood market in the U.S., and the numbers continue to grow. Today's transformation in the wood market means that tomorrow our ancient forests may still be standing.

**Your action can make a difference.**

With your help, we at Rainforest Action Network can continue to move old growth products out of the U.S. marketplace and protect the planet's last ancient forests. Please send your contribution today.



**RAINFOREST  
ACTION NETWORK**

221 PINE STREET, SUITE 500  
SAN FRANCISCO, CA 94104  
(415) 398-4404 [WWW.RAN.ORG](http://WWW.RAN.ORG)